

BIDDING DOCUMENTS

PROJECT: PAVING OF OLD BEND-REDMOND HWY/
S CANAL BLVD: TUMALO RD TO
HELMHOLTZ WAY

PROJECT #: W66141

BID OPENING: APRIL 24, 2024

COMPLETION DATE: AUGUST 31, 2024

CONTRACTING AGENCY:



ROAD
DEPARTMENT

61150 SE 27TH STREET
BEND, OREGON 97702
PHONE: (541) 388-6581
FAX: (541) 388-2719
WEB: www.deschutescounty.gov/road



ROAD
DEPARTMENT

BIDDING DOCUMENTS

PAVING OF OLD BEND-REDMOND HWY/ S CANAL BLVD: TUMALO RD TO HELMHOLTZ WAY

TABLE OF CONTENTS

INVITATION TO BID.....	A1
INFORMATION FOR BIDDERS	A2
BID PROPOSAL FORM.....	B1
SCHEDULE OF BID ITEMS	B4
SUBCONTRACTOR DISCLOSURE FORM	B5
BID GUARANTY FORM	B6
CONTRACT AGREEMENT FORM (FOR INFORMATION ONLY).....	C1
PERFORMANCE BOND FORM (FOR INFORMATION ONLY)	C3
PAYMENT BOND FORM (FOR INFORMATION ONLY).....	C5
CERTIFICATION OF WORKERS' COMPENSATION COVERAGE (FOR INFORMATION ONLY)	C7
SPECIAL PROVISIONS	SP1
PROJECT PLANS	

DESCRIPTION OF PARTS OF BIDDING DOCUMENTS WHICH ARE NOT BOUND HEREIN:

OREGON STANDARD SPECIFICATIONS FOR CONSTRUCTION, 2024

The Specification that is applicable to the Work on this Project is the 2024 edition of the "Oregon Standard Specifications for Construction". All number references in these Special Provisions shall be understood to refer to the Sections and subsections of the Standard Specifications bearing like numbers and to Sections and subsections contained in these Special Provisions in their entirety.

**DESCHUTES COUNTY, OREGON
ROAD DEPARTMENT
INVITATION TO BID
PAVING OF OLD BEND-REDMOND HWY/ S CANAL BLVD:
TUMALO RD TO HELMHOLTZ WAY**

Sealed bids will be received at the Deschutes County Road Department, 61150 SE 27th Street, Bend, Oregon 97702, until but not after, **2:00 p.m. on April 24, 2024**, at which time and place all bids for the above-entitled public works project will be publicly opened and read aloud.

The Class of Work of this Project is Asphalt Concrete Paving and Oiling. The value for this Contract is estimated to be between \$2,700,000 and \$3,300,000. The Work will consist of, but not be limited to, the following:

- Install and maintain temporary traffic control.
- Perform isolated asphalt concrete pavement repair.
- Perform cold plane pavement removal.
- Construct new asphalt concrete pavement.
- Install permanent pavement markings and delineation.
- Perform additional and incidental work as called for by the Specifications and Plans.

Specifications and other bid documents may be inspected and obtained from the Deschutes County Bids and RFPs website at <https://www.deschutescounty.gov/rfps>. Inquiries pertaining to these specifications shall be directed to Blaine Wruck, Transportation Engineer, in writing at Blaine.Wruck@deschutescounty.gov or the address above.

Bids shall be made on the forms furnished by the County, including a Bid Bond or Cashiers Check for the minimum amount of 10% of the Bid Price, addressed and mailed or delivered to Chris Doty, Department Director, 61150 SE 27th Street, Bend, Oregon 97702 in a sealed envelope plainly marked "BID FOR PAVING OF OLD BEND-REDMOND HWY/ S CANAL BLVD: TUMALO RD TO HELMHOLTZ WAY" and the name and address of the bidder.

Bidders must submit a Subcontractor Disclosure Statement. The subcontractor disclosure statement may be submitted in the sealed bid prior to 2:00 p.m. on April 24, 2024 or in a separate sealed envelope marked "SUBCONTRACTOR DISCLOSURE STATEMENT - PAVING OF OLD BEND-REDMOND HWY/ S CANAL BLVD: TUMALO RD TO HELMHOLTZ WAY" prior to 4:00 p.m. on April 24, 2024 at the above location.

Because the work called for under this contract is for a public works project subject to state prevailing rates of wage under ORS 279C.800 to 279C.870, the County will not receive or consider a bid unless the bid contains a statement by the bidder that the bidder will comply with ORS 279C.838 and ORS 279C.840. Each bid must contain a statement as to whether the bidder is a resident bidder, as defined in ORS 279A.120. Vendors shall use recyclable and/or sustainably sourced products to the maximum extent economically feasible in the performance of the contract work set forth in this document.

Bidders shall be prequalified with the State of Oregon for the Class of Work stated above in accordance with ORS 279C.430 through 279C.450 and Deschutes County Code 12.52.020. The successful bidders and subcontractors providing labor shall maintain a qualified drug testing program for the duration of the contract. Bidders shall be licensed with the Construction Contractor's Board. Contractors and subcontractors need not be licensed under ORS 468A.720.

Deschutes County may reject any bid not in compliance with all prescribed bidding procedures and requirements, and may reject for good cause any or all bids upon a finding of Deschutes County it is in the public interest to do so. The protest period for this procurement is seven (7) calendar days.

CHRIS DOTY
Road Department Director

PUBLISHED:
DAILY JOURNAL OF COMMERCE: April 3, 2024
THE BEND BULLETIN: April 3, 2024

INFORMATION FOR BIDDERS

1. **General Description of Project.** A general description of the Work to be performed is contained in the Invitation to Bid. The scope is indicated in the applicable parts of these Solicitation Documents.
2. **Solicitation Documents.** The Solicitation Documents under which it is proposed to execute the Work consist of the material bound herewith. These solicitation documents are intended to be mutually complementary and to provide all details reasonably required for the execution of the proposed work.
3. **Form of Proposals.** All proposals must be submitted on the forms furnished. Subcontractor disclosure form may be submitted with the bid or in a separate envelope.
4. **Substitutions.** Materials and/or products called for in the specifications are named in order to establish a standard of quality design. Manufacturers or suppliers of products similar to those specified may submit bids on the work providing requests for approval of substitution materials are made at least seven (7) calendar days prior to the bid opening. Adequate information on which to base approval or disapproval must be furnished to the Road Department Director or his representative and the Road Department Director shall be the sole judge of any request. When the Road Department Director approves a substitution, it is with the understanding that the Contractor guarantees the substituted article or materials to be equal or better than the specified.
5. **Preparation of Proposals.** All blank spaces in the proposal form must be filled in, in ink, or typed, in both words and figures where required. No changes shall be made in phraseology of the forms. Written amount shall govern in cases of discrepancy between the amount stated in writing and amount stated in figures.

Any proposal shall be deemed informal which contains omissions, erasures, alterations, or additions of any kind, or prices uncalled for, or which, in any manner shall fail to conform to the conditions of the published invitation to bidders.

The bidder shall sign his/her proposal in the blank space provided therefore. Proposals made by corporations or partnerships shall contain names and addresses of the principal officers or partners therein. If a corporation makes a proposal, it must be signed by one of the principal officers thereof, and the corporate seal affixed.

If made by a partnership, it must be signed by one of the partners, clearly indicating that he is signing as a partner of the firm. In the case of a proposal made by a joint venture, each of the joint venturers must sign the proposal in his personal capacity.

The wording of the proposal shall not be changed. Any additions, conditions, limitations or provisions inserted by the bidder will render the proposal irregular and may cause its rejection.

6. **Submission of Proposals.** All proposals must be submitted in the time and place and in the manner prescribed in the invitation to bid. Proposals must be made on the prescribed proposal forms furnished. Each proposal must be submitted in a sealed envelope, so marked as to indicate its contents without being opened. If the proposal is submitted by mail, the sealed envelope containing the bid must be enclosed in a separate envelope plainly addressed for mailing to conformance with instructions in the Invitation to Bid.

A responsive bid proposal must include the completed items listed in Section 18 of the Information for Bidders.

7. **Modification or Withdrawal of Proposal.** Any bidder may modify his bid by written or telegraphic communication at any time prior to the scheduled closing time for receipt of bids, provided such communication is received by the County prior to the closing time, and provided further that a written confirmation of a telegraphic modification over the signature of the bidder was mailed prior to the closing time. If written confirmation of a telegraphic communication is not received within at least two calendar days of the closing time, no consideration will be given to the modification. The written or telegraphic communication should not reveal the bid price, but should state the addition or subtraction or other modification so that the County will not know the final prices or terms until the sealed bid is opened.

Proposals may be withdrawn prior to the scheduled time for the opening of the proposals either by telegraphic or written request, or in person. No proposal may be withdrawn after the time scheduled for opening of proposals, unless the County has failed to comply with the time limits applicable to award of the Contract.

8. **Disclosure of First Tier Subcontractors.** Bidders are required to disclose information about certain first-tier subcontractors (see ORS 279C.370). Specifically, when the contract amount of a first-tier subcontractor furnishing labor or labor and materials would be greater than or equal to: (i) 5% of the project Bid, but at least \$15,000; or (ii) \$350,000 regardless of the percentage, the Bidder must disclose the following information about that subcontract either in its Bid submission, or within two hours after Bid Closing:

(A) The subcontractor's name;

(B) The category of Work that the subcontractor would be performing, and

(C) The dollar value of the subcontract.

If the Bidder will not be using any subcontractors that are subject to the above disclosure requirements, the Bidder is required to indicate "NONE" on the accompanying form.

THE CONTRACTING AGENCY MUST REJECT A BID IF THE BIDDER FAILS TO SUBMIT THE DISCLOSURE FORM WITH THIS INFORMATION BY THE STATED DEADLINE (see OAR 137-049-0360).

A Bidder shall submit the disclosure form either in its Bid submission or within two working hours after Bid Closing in the manner specified by the Invitation to Bid.

Compliance with the disclosure and submittal requirements of ORS 279C.370 and OAR 137-049-0360 is a matter of Responsiveness. Bids that are submitted by Bid Closing, but for which the disclosure submittal has not been made by the specified deadline, are not Responsive and shall not be considered for Contract Award.

Substitution of affected first-tier subcontractors shall be made only in accordance with ORS 279C.585.

9. **Bid Security.** The Bid Bond or Cashier's Check will be for a minimum of ten per cent (10%) of the amount of the bid price. If a bidder bids more than one bid proposal, each proposal must be accompanied by separate bid security. The County reserves the right to retain the bid security of the three (3) lowest bidders until the successful bidder has signed and delivered the contract and furnished one hundred percent (100%) Performance and Payment Bonds.
10. **Conditions of Work.** Each bidder must inform himself of the conditions relating to the execution of the work, and make himself thoroughly familiar with all the Contract documents. Failure to do so will not relieve the successful bidder of his obligations to enter into a Contract and complete the contemplated work in strict accordance with the Contract documents. Each bidder must inform himself on all laws and statutes, both Federal and State, relative to the regular execution of the work, the employment of labor, protection of public health, access to the work and similar requirements.
11. **Award of Contract.** The award of the contract will be made by the County on the basis of the proposal which in its sole and absolute judgment will best serve the interest of the County.

County will issue a notice of intent to award contract. Any bidder may protest the notice of intent to award contract within seven (7) calendar days of the notice of intent to award contract.

The County reserves the right to accept or reject any or all proposals, and to waive any informalities and irregularities in said proposals.

12. **Payment and Retainage.** Payment for work performed will be made by the County as specified in the Special Provisions based upon the contract unit prices on the Bid Schedule.

Upon substantial completion of the contract, Contractor may request a partial release of retainage held by the County. The maximum amount of a request for a partial release retainage shall be the Contract amount less 150 percent of the estimated cost of the Contract yet to be performed through final completion. Upon final completion, Contractor may request release of the remaining retainage. Each request for the release of retainage shall be accompanied by the Consent of the contractor's surety.

13. **Performance Bond and Payment Bond.** The successful bidder shall file with the County, at the time of execution of the contract, a Performance Bond and a Payment Bond each of not less than the contract price on the forms furnished by the County. The Surety Company furnishing the required bonds shall have a sound financial standing and a record of service satisfactory to the County, and shall be authorized to do business in the State of Oregon. In lieu of a Performance Bond, the contractor may file cash, a Certified or Cashier's Check made payable to Deschutes County, Oregon. This money, check or certificate will be held by the County conditioned on and subject to the same provisions as set forth in the attached Performance Bond. ORS 279C.380 allows no flexibility for a cash deposit in lieu of a Payment Bond.
14. **Required Public Works Bond.** Before starting work on this project the Contractor and every subcontractor to which Contractor is a party for the performance of work under this contract must have a public works bond filed with the Construction Contractors Board, 700 Summer St. NE, Suite 300, Salem, Oregon 97309-5052, before starting work on the project, unless exempt under section 2 (7) or (8) of 2005 Oregon Laws Chapter 360 ORS 279C.836(7) or (8). Every subcontract to which Contractor is a party for the performance of work under this contract shall contain a provision requiring the subcontractor to have a public works bond filed with the Construction Contractors Board before starting work on this project, unless exempt under ORS 279C.836 (7) or (8) section 2 (7) or (8) of 2005 Oregon Laws Chapter 360.
15. **Failure to Execute Contract.** Upon failure by the successful bidder to enter into the Contract and furnish the necessary bond within fifteen (15) calendar days from the date the Contract documents are sent or otherwise conveyed to the Bidder, the bid bond accompanying the bid shall be forfeited, the proceeds paid to the County, and the award withdrawn. The award may then be made to the next lowest responsible bidder, or all bids rejected and the work is re-advertised.
16. **Disclaimer of Responsibility.** Neither the County nor the Road Department Director will be responsible for oral interpretations. Should a bidder find discrepancies in, or omissions from the drawings, specifications, or other pre-bid documents, or be in doubt as to their meaning, he shall notify the County at least seven (7) calendar working days prior to the bid opening date. Any and all such interpretations, any supplemental instructions or approval of manufacturer's materials to be substituted will be made only in the form of written addenda to the specifications, which, if issued, will be hand delivered or sent by regular mail, email and fax to all prospective bidders receiving a set of such documents, not later than two (2) calendar days prior to the date fixed for the opening of bids. Failure of any bidder to receive any such addendum or interpretation shall not relieve such bidder from any obligation under his bid as submitted. All addenda so issued are to be covered in the bid for such addenda to become part of the Agreement.
17. **Permits and Licenses.** The successful bidder shall be required to have or obtain, at his expense, any and all permits and licenses required by Deschutes County, any City within the County, and the State of Oregon, pertaining to the service he proposes to furnish. Licensing shall include

without limitation registration with Construction Contractors Board and in the case of professional engineers and architects proof of current licensing with the appropriate State licensing board.

18. **Minimum Requirements of Bid.** The following minimum requirements as to the form and manner of submitting bids must be strictly observed; variance from these requirements will result in rejection of the bid as unresponsive.
- a. Each Bid must be submitted on forms furnished by the County. The completed forms required for a bid to be considered responsive, which are included herein, are listed below:
 - Bid Proposal Form
 - Schedule of Bid Items
 - First-Tier Subcontractor Disclosure Form
 - Bid Bond
 - Signed Addenda (if issued)
 - b. Each Bid must be signed by the bidder.
 - c. Bid security, in the required form and amount, must accompany each bid.
 - d. Each blank in the proposal must be filled in unless an alternative is provided. Each separate bid item must be bid on, unless the proposal form clearly indicates otherwise.
 - e. Each Bid must be submitted in a separate sealed envelope, marked to identify without opening, and in the hands of the Road Department Director at the time and place specified for bid opening.
 - f. A proposal containing modifications, deletions, exceptions or reservations which in any way conflict with or purport to alter any substantive provision contained in the bid documents, will not be considered.
 - g. A conditional bid will not be considered.
 - h. Any bid submitted without all of the pages of the bid documents shall be deemed to have been submitted with the missing pages for purposes of bid evaluation if, at a minimum, the completed pages identified above in (a) are included in the submission. The missing pages of the bid documents shall be deemed to be incorporated into bid by reference.
19. **Plans.** Plans are not to be taken or construed as being reproduced at precisely the indicated scale. Where the plans are photographic reductions of the original tracings, the approximate amount of reduction is indicated by a note on the plans.
20. **Specifications.** The specifications are the minimum acceptable specifications for the project for which proposals are sought. Any deviation

from the specifications contained herein, shall render the bid non-responsive.

21. **Examination of Site and Conditions.** Bidders are required, prior to submission of bids, to carefully examine the site and the Plans and Specifications of the contemplated work. Errors and omissions in the Plans or Specifications shall be called to the attention of the Agency prior to submission of bid so that addenda may be issued. Failure to do so on the part of the Contractor does not relieve him of responsibility for a correct and completely finished job. Only a written interpretation or correction by addendum shall be binding.
22. **Pre-Bid Inquiries.** Bidders with pre-bid inquiries shall contact Blaine Wruck, Transportation Engineer, in writing at:

Email: blaine.wruck@deschutescounty.gov; or

Mailing Address: 61150 SE 27th Street, Bend, Oregon 97702.

Contracting Agency will not mail notice of Addenda, but will publish notice of any Addenda on Contracting Agency's Web site. Addenda may be downloaded off the Contracting Agency's Web site. Bidders should frequently check the Contracting Agency's Web site until closing, i.e., at least once weekly until the week of Closing and at least once daily the week of the Closing.

23. **Prequalification of Bidders.** Bidders shall be pre-qualified with the State of Oregon in accordance with ORS 279C.430 and Deschutes County Code 12.52.020. The prequalification class is as shown in the Invitation to Bid. Bidders shall be prequalified in the appropriate class of work at the time of bid opening. Bidders shall be licensed with the Construction Contractor's Board under OAR 137-049-0230. Contractors and subcontractors need not be licensed under ORS 468.710.
24. **Contract Award.** Deschutes County reserves the right to postpone award of the contract for fourteen (14) calendar days from the date of the bid opening, or until a final decision is made on a protest, whichever is later.
25. **Bidder Statement.** This Contract is subject to ORS 279C.800 to ORS 279C.870. Submission of a bid for the project shall constitute a statement that the bidder agrees to be bound by and will comply with provisions of 279C.838, 279C.840 or 40 U.S.C. 3141 to 3148. The successful bidder and subcontractors providing labor shall maintain a qualified drug-testing program for the duration of the Contract.

By submitting a bid for the project, the bidder certifies that the bidder has not discriminated and will not discriminate against any disadvantaged business enterprise, minority-owned business, women-owned business, emerging small business, or business that a service-disabled veteran owns, in obtaining any required subcontracts. Failure to do so shall be grounds for disqualification.

BID PROPOSAL FORM

PAVING OF OLD BEND-REDMOND HWY/ S CANAL BLVD: TUMALO RD TO HELMHOLTZ WAY

BIDDER NAME

CCB#

ADDRESS

CITY

STATE

ZIP CODE

CONTACT NAME

CONTACT PHONE NUMBER

CONTACT EMAIL ADDRESS

The undersigned, hereinafter called the Bidder, declares that the only persons or parties interested in this Proposal are those named herein; that this Proposal is, in all respects, fair and without fraud; and it is made without collusion with any official of Deschutes County, Oregon, hereinafter called County; and that the Proposal is made without any connection or collusion with any person making another proposal on this contract.

The Bidder further declares that Bidder has carefully examined the contract documents; that Bidder is satisfied as to the quantities involved, including materials and equipment, and conditions of work involved; and that this proposal is made according to the provisions and under the terms of the contract documents, which documents are hereby made a part of this Proposal.

The Bidder agrees that all of the applicable provisions of Oregon law relating to public contracts (ORS Chapter 279) are, by this reference, incorporated in and made a part of this Proposal.

The Bidder declares that (check appropriate box):

Bidder is a resident bidder of the State of Oregon.

Bidder is a nonresident bidder from the State of _____.

The Bidder declares that Bidder is not in violation of any tax laws of the State of Oregon and Deschutes County, including but not limited to those programs listed in ORS 305.380(4),

The Bidder further agrees that if this Proposal is accepted, Bidder will, within fifteen (15) calendar days after conveyance of the contract documents to the Bidder, execute the contract with the County in the form of contract annexed hereto; and will, at the time of execution of the contract, deliver to the County the Performance and Payment Bonds (See Section 13 Information for Bidders) required herein; and will, to the extent of this Proposal, furnish all materials necessary to complete the work in the manner, in the time, and according to the methods as specified in the contract documents and required by the Road Department Director.

The Bidder certifies that it has a drug testing program in place for its employees, or warrants that a drug testing program will be in place prior to execution of this contract, that the drug testing program is in writing, that new employees must pass a drug screening, that existing employees may be tested for reasonable cause or when an employee is injured or involved in an accident resulting in property

damage. The Bidder agrees that each subcontractor providing labor under this Contract shall maintain a qualifying drug testing program for the duration of the Contract.

The Bidder agrees to comply with the provisions of 279C.838, 279C.840 or 40 U.S.C. 3141 to 3148 ORS 279C.840.

The Bidder certifies that the Bidder has not discriminated and will not discriminate against any disadvantaged business enterprise, minority-owned business, women-owned business, emerging small business, or business that a service-disabled veteran owns, in obtaining any required subcontracts in accordance with ORS 279A.110(4).

The Bidder agrees to commence work upon the issuance of a "Notice to Proceed" by the County and fully complete the project according to the time schedule specially set forth in the contract documents.

The Bidder further agrees to pay liquidated damages for failure to complete within the specified time.

It is agreed that if the Bidder is awarded the contract for the work herein proposed and shall fail or refuse to execute the contract and furnish the contract and furnish the specified Performance and Payment Bond within fifteen (15) calendar days after the contract documents are sent or otherwise conveyed to the Bidder, then, in that event, the bid security deposited herewith according to the conditions of the Invitation to Bid and Information for Bidders shall be retained by the County as liquidated damages; and it is agreed that the said sum is a fair measure of the amount of damage the County will sustain in case the Bidder shall fail or refuse to enter into the contract for the said work and to furnish the Performance and Payment Bonds (See Section 13 Information for Bidders) as specified in the contract documents. Bid security in the form of a certified check shall be subject to the same requirements as a bond.

(SIGNATURE PAGE TO FOLLOW)

(IF SOLE PROPRIETOR OR PARTNERSHIP)

IN WITNESS HERETO, the undersigned has set hand this _____ day of _____, 2024.

SIGNATURE OF BIDDER

TITLE

(IF CORPORATION)

IN WITNESS WHEREOF, the undersigned corporation has caused this instrument to be executed and its seal affixed by its duly authorized officers this _____ day of _____, 2024.

NAME OF CORPORATION

By: _____

Title: _____

Attest: _____

(SCHEDULE OF BID ITEMS TO FOLLOW)

ITEM NO.	SPEC SECTION	ITEM	UNIT	QTY	UNIT PRICE	AMOUNT
<u>Part 00200 - Temporary Features and Appurtenances</u>						
001	00210	Mobilization	LS	1	\$ _____	\$ _____
002	00221	Temporary Protection and Direction of Traffic	LS	1	\$ _____	\$ _____
003	00222	Temporary Signs	SQFT	649	\$ _____	\$ _____
004	00222	Portable Changeable Message Signs	EACH	4	\$ _____	\$ _____
005	00223	Flaggers	HOUR	1,048	\$ _____	\$ _____
006	00223	Pilot Cars	HOUR	317	\$ _____	\$ _____
007	00225	Stripe Removal	FOOT	1,000	\$ _____	\$ _____
<u>Part 00600 - Bases</u>						
008	00620	Cold Plane Pavement Removal, 3 Inches Deep	SQYD	99,700	\$ _____	\$ _____
009	00640	Aggregate Shoulders	TON	1,650	\$ _____	\$ _____
<u>Part 00700 - Wearing Surfaces</u>						
010	00744	Level 3, 1/2 Inch ACP Mixture	TON	17,600	\$ _____	\$ _____
011	00748	16 Inch Asphalt Concrete Pavement Repair	SQYD	200	\$ _____	\$ _____
012	00749	Extra for Asphalt Approaches	EACH	12	\$ _____	\$ _____
<u>Part 00800 - Permanent Traffic Safety and Guidance Devices</u>						
012	00840	Delineators, Type 1	EACH	264	\$ _____	\$ _____
013	00855	Bi-Directional Yellow Type IAR Markers, Recessed	EACH	782	\$ _____	\$ _____
014	00865	Thermoplastic, Sprayed Surface, Non-Profiled	FOOT	148,000	\$ _____	\$ _____
015	00867	Pavement Bar, Type AB	SQFT	165	\$ _____	\$ _____
016	00867	Pavement Legend, Type AB: "STOP"	EACH	7	\$ _____	\$ _____
017	00867	Pavement Legend, Type AB: "STOP AHEAD"	EACH	5	\$ _____	\$ _____

TOTAL BID: _____

FOR DESCHUTES COUNTY USE ONLY	ADD _____	% FOR NON-RESIDENT BIDDER	
			TOTAL BID _____

FIRST-TIER SUBCONTRACTOR DISCLOSURE FORM

Project Name: PAVING OF OLD BEND-REDMOND HWY/ S CANAL BLVD:
TUMALO RD TO HELMHOLTZ WAY

Bid #: W66141 Bid Closing Date: April 24, 2024 Time: 2:00 P.M.

Name of Bidding Contractor: _____

This form must be submitted at the location specified in the Invitation to Bid on the advertised bid closing date and within two working hours (4:00 p.m.) after the advertised bid closing time.

List below the name of each subcontractor that will be furnishing labor or materials and that is required to be disclosed, the category of work that the subcontractor would be performing and the dollar value of the subcontract. Enter "NONE" if there are no subcontractors that need to be disclosed. (ATTACH ADDITIONAL SHEETS IF NEEDED).

	NAME	DOLLAR VALUE	CATEGORY OF WORK
1)	_____	\$ _____	_____
2)	_____	\$ _____	_____
3)	_____	\$ _____	_____
4)	_____	\$ _____	_____
5)	_____	\$ _____	_____
6)	_____	\$ _____	_____
7)	_____	\$ _____	_____
8)	_____	\$ _____	_____

Failure to submit this form by the disclosure deadline will result in a non-responsive bid. A non-responsive bid will not be considered for award.

Form submitted by

Bidder name: _____

Contact name: _____ Phone number: _____

BID BOND

KNOW ALL MEN BY THESE PRESENTS, That _____

_____ ,

hereinafter called the Principal, and _____

_____ ,

a corporation duly organized under the laws of the State of _____ ,

having its principal place of business at _____

_____ , in the State of _____ ,

and authorized to do business in the State of Oregon, as Surety, are held and firmly bound unto the

County of Deschutes, hereinafter called the Obligee, in the penal sum of _____

_____ DOLLARS (\$ _____),

for the payment of which, well and truly to be made, we bind ourselves, our heirs, executors, administrators, successors and assigns, jointly and severally, firmly by these presents.

The condition of this Bond is that, whereas, the Principal is submitting a bid proposal for the PAVING OF OLD BEND-REDMOND HWY/ S CANAL BOULEVARD: TUMALO ROAD TO HELMHOLTZ WAY project hereby made a part hereof;

NOW THEREFORE, if the said bid proposal submitted by the said principal be accepted, and the contract be awarded to said Principal, and if the said Principal shall execute the proposed contract and shall furnish the Performance and Payment Bond as required by the bidding and contract documents with the time fixed by said documents, then this obligation shall be void, otherwise to remain in full force and effect. Signed and sealed this _____ day of _____, 2024.

SURETY:

CONTRACTOR:

Name

Name

By: _____

By: _____

Title: _____

Title: _____

CONTRACT

FOR

PAVING OF OLD BEND-REDMOND HWY/ S CANAL BLVD: TUMALO RD TO HELMHOLTZ WAY

THIS CONTRACT is made and entered into, this _____ day of _____, 2024, by and between DESCHUTES COUNTY, a political subdivision of the State of Oregon, by and through its Board of County Commissioners, hereinafter called "County", and _____, an Oregon corporation, hereinafter called "Contractor."

WITNESSTH:

THAT the said Contractor, in consideration of the sums to be paid by the County in the manner and at the time herein provided, and in consideration of the other covenants and agreements herein contained, hereby agrees to perform and complete the work herein described and provided for and to furnish all necessary machinery, tools, apparatus, equipment, supplies, materials and labor and do all things in accordance with the applicable Plans, the applicable Standard Specifications, the Special Provisions and other required provisions bound herewith or incorporated therein, and in accordance with such alterations or modifications of the same as may be made by the County, and according to such directions as may from time to time be made or given by the Engineer under the authority and within the meaning and purpose of this Contract. This agreement shall be binding upon the heirs, executors, administrators, successors and assigns of the Contractor.

THAT the applicable Plans, the applicable Standard Specifications, the Special Provisions and other required provisions bound herewith or incorporated therein and the Schedule of Items bound herewith are hereby specifically referred to and by this reference made a part hereof, and shall by such reference have the same force and effect as though all of the same were fully written or inserted herein.

THAT the Contractor shall faithfully complete and perform all of the obligations of this Contract, and in particular, shall promptly, as due, make payment of all just debts, dues, demands and obligations incurred in the performance of said Contract; and shall not permit any lien or claim to be filed or prosecuted against the County, its agents or employees. It is expressly understood that the laws of the State of Oregon and the Ordinances of the County shall govern this Contract in all things.

THAT in consideration of the faithful performance of all of the obligations, general and special, herein set out, and in consideration of the faithful performance of the work as set forth in the Contract Documents in accordance with the directions and to the satisfaction of the Engineer, the County agrees to pay to the said Contractor the amount earned, as determined from the actual quantities of work performed, and taking into consideration any amounts that may be deductible and under the terms of the Contract, and to make such payments in the manner and at the times provided in the applicable provisions.

(SIGNATURE PAGE TO FOLLOW)

IN WITNESS WHEREOF, the parties hereto have subscribed their names and affixed their respective official seals as of the date first above written

CONTRACTOR

**BOARD OF COUNTY COMMISSIONERS
OF DESCHUTES COUNTY, OREGON**

BY: _____

PATTI ADAIR, CHAIR

TITLE: _____

ANTHONY DEBONE, VICE CHAIR

DATE: _____

PHIL CHANG, COMMISSIONER

ATTEST:

RECORDING SECRETARY

APPROVED AS TO CONTENT:

ROAD DEPARTMENT DIRECTOR

APPROVED AS TO FORM:

COUNTY LEGAL COUNSEL

Bond # _____

PERFORMANCE BOND

KNOW ALL MEN BY THESE PRESENTS: that

(Name of Contractor)

(Address of Contractor)

a _____, hereinafter called
(Corporation, Partnership, or Individual)

“Principal”, and _____
(Name of Surety)

hereinafter called “Surety”, are held and firmly bound unto Deschutes County, Oregon

hereinafter called “Owner”, in the penal sum of _____

_____ Dollars, \$(_____)
in lawful money of the United States, for the payment of which sum well and truly to be made,
we bind ourselves, successors, and assigns, jointly and severally, firmly by these presents.

THE CONDITION OF THIS OBLIGATION is such that whereas, the Principal entered into a
certain contract with the OWNER, dated the _____ day of _____, 2024, a copy of
which is hereto attached and made a part hereof for the construction of:

**PAVING OF OLD BEND-REDMOND HWY / S CANAL BLVD:
TUMALO RD TO HELMHOLTZ WAY**

NOW THEREFORE, if Principal shall well, truly and faithfully perform its duties, all the
undertakings, covenants, terms, conditions, and agreements of said contract during the original
term thereof, and any extensions thereof which may be granted by Owner, with or without notice
to Surety and during the **two year guaranty period**, and if Principal shall satisfy all claims and
demands incurred under such contract, and shall fully indemnify and save harmless Owner from
all costs and damages which is may suffer by reason of failure to do so, and shall reimburse
and repay Owner all outlay and expense which Owner may incur in making good any default,
then this obligation shall be void; otherwise to remain in full force and effect.

PROVIDED FURTHER, that Surety, for value received hereby stipulates and agrees that no
change, extension of time, alteration or addition to the terms of the contract or to work to be
performed thereunder or the specifications accompanying the same shall in any wise affect its
obligation on this bond, and it does hereby waive notice of any such change, extension of time,
alteration or addition to the terms of the contract or to the work or the specifications.

PROVIDED, FURTHER, that no final settlement between Owner and Principal shall abridge the right of any beneficiary hereunder, whose claim may be unsatisfied.

IN WITNESS WHEREOF, this instrument is executed in two counterparts, each one of which shall be deemed an original, this the _____ day of _____ 2024.

(SEAL)

PRINCIPAL: _____

By _____
Signature

Official Capacity

Attest: _____
Corporation Secretary

(SEAL)

SURETY: _____
[Add signatures for each surety if using multiple bonds]

BY ATTORNEY-IN-FACT:
[Power-of-Attorney must accompany each surety bond]

Name

Signature

Address

City State Zip

Phone Fax

NOTE: Date of bond must not be prior to date of Contract.
If Contractor is Partnership, all partners should execute bond.

Bond # _____

PAYMENT BOND

KNOW ALL MEN BY THESE PRESENTS: that

(Name of Contractor)

(Address of Contractor)

a _____, hereinafter called
(Corporation, Partnership, or Individual)

“Principal”, and _____
(Name of Surety)

hereinafter called “Surety”, are held and firmly bound unto Deschutes County, Oregon

hereinafter called “Owner”, in the penal sum of _____

_____ Dollars, \$(_____)
in lawful money of the United States, for the payment of which sum well and truly to be made,
we bind ourselves, successors, and assigns, jointly and severally, firmly by these presents.

THE CONDITION OF THIS OBLIGATION is such that whereas, the Principal entered into a
certain contract with the OWNER, dated the _____ day of _____, 2024, a copy of
which is hereto attached and made a part hereof for the construction of:

**PAVING OF OLD BEND-REDMOND HWY / S CANAL BLVD:
TUMALO RD TO HELMHOLTZ WAY**

NOW, THEREFORE, if Principal shall promptly make payment to all persons, firms,
subcontractors, and corporations furnishing materials for or performing labor in the prosecution
of the work provided for in such contract, and any authorized or modification thereof, including
all amounts due for materials, lubricants, oil, gasoline, coal and coke, repairs on machinery,
equipment and tools, consumed or used in connection with the construction of such work, and
all insurance premiums on said work, and for all labor, performed in such work whether by
subcontractor or otherwise, then this obligation shall be void; otherwise to remain in full force
and effect.

PROVIDED, FURTHER, that Surety for value received hereby stipulates and agrees that no
change, extension of time, alteration or addition to the terms of the contract or to the work to be
performed thereunder or the specifications accompanying the same shall in any wise affect its
obligation on this bond, and it does hereby waive notice of any such change, extension of time,
alteration or addition to the terms of the contract or to the work or to the specifications.

PROVIDED, FURTHER, that no final settlement between Owner and Principal shall abridge the right of any beneficiary hereunder, whose claim may be unsatisfied.

IN WITNESS WHEREOF, this instrument is executed in two counterparts, each one of which shall be deemed an original, this the _____ day of _____, 2024.

(SEAL)

PRINCIPAL: _____

By _____
Signature

Official Capacity

Attest: _____
Corporation Secretary

(SEAL)

SURETY: _____
[Add signatures for each surety if using multiple bonds]

BY ATTORNEY-IN-FACT:
[Power-of-Attorney must accompany each surety bond]

Name

Signature

Address

City State Zip

Phone Fax

NOTE: Date of bond must not be prior to date of Contract.
If Contractor is Partnership, all partners should execute bond.

CERTIFICATION OF WORKERS' COMPENSATION COVERAGE

Deschutes County:

The Contractor, for the purposes of this Contract, hereby certifies that it is currently providing Oregon Workers' Compensation coverage for all its employees and will maintain coverage throughout the course of the project through one of the following methods:

1. "Carrier-Insured Employer" (State Accident Insurance Fund Corp. or other authorized insurer)

Insurance Company Name _____

ID/Policy Number _____

2. "Self-Insured Employer" (Certified by the Workers' Compensation Division)

ID number as assigned by the
Workers' Compensation Division _____

3. I am an independent contractor and will perform all work under this contract without the assistance of others.

In the event of cancellation or change in the information above, Contractor certifies that it will immediately notify the Agency of said cancellation or change and will obtain alternate coverage.

Dated _____, 2024

(Contractor's Signature)

REMINDER - ADDITIONAL INFORMATION NEEDED

Has your insurance carrier filed with Oregon Workers' Compensation Division a guaranty contract as proof of coverage for your employees working in Oregon?

For filing information, contact the Workers' Compensation Division at Labor and Industries Building: Salem, OR 97310; Phone (503) 947-7810.

SPECIAL PROVISIONS

PROJECT: PAVING OF OLD BEND-REDMOND HWY / S CANAL
BLVD: TUMALO RD TO HELMHOLTZ WAY

PROJECT #: W66141

CONTRACTING AGENCY:



**ROAD
DEPARTMENT**

**61150 SE 27TH STREET
BEND, OREGON 97702
PHONE: (541) 388-6581
FAX: (541) 388-2719
WEB: www.deschutescounty.gov/road**

PROFESSIONAL OF RECORD CERTIFICATION:

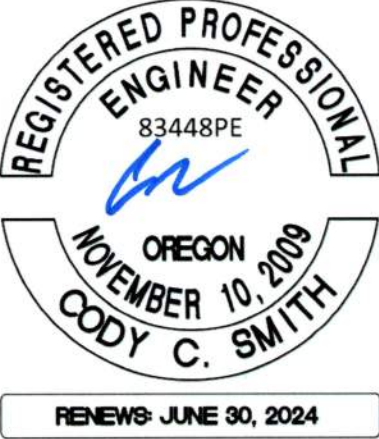
<p>Seal w/signature</p>  <p>REGISTERED PROFESSIONAL ENGINEER 83448PE OREGON NOVEMBER 10, 2009 CODY C. SMITH RENEWS: JUNE 30, 2024</p>	<p>I certify the Special Provision Section(s) listed below are applicable to the design for the subject project. Modified Special Provisions were prepared by me or under my supervision.</p> <p>Sections <u>00210 through 00867</u></p>
<p>Date Signed: <u>4-2-2024</u></p>	

SPECIAL PROVISIONS

WORK TO BE DONE

The work to be done under this contract consists of the following on the PAVING OF OLD BEND-REDMOND HWY/S CANAL BLVD: TUMALO RD TO HELMHOLTZ WAY project:

1. Install and maintain temporary traffic control.
2. Perform isolated asphalt concrete pavement repair.
3. Perform cold plane pavement removal.
4. Construct new asphalt concrete pavement.
5. Install permanent pavement markings.
6. Perform additional and incidental work as called for by the specifications and plans.

APPLICABLE SPECIFICATIONS

The Specification that is applicable to the Work on this Project is the 2024 edition of the “Oregon Standard Specifications for Construction.”

All number references in these Special Provisions shall be understood to refer to the Sections and subsections of the Standard Specifications and Supplemental Specifications bearing like numbers and to Sections and subsections contained in these Special Provisions in their entirety.

Copies of the Oregon Standard Specifications may be purchased or viewed online at

https://www.oregon.gov/odot/business/pages/standard_specifications.aspx

APPLICABLE RULES

The rules applicable to this contract are the Attorney General’s Model Public Contract Rules, Chapter 137-046 and Chapter 137-049, as presently constituted and Deschutes County Code (DCC) Chapter 2.37. The provisions of DCC Chapter 2.37.150 are incorporated herein by reference. These provisions may be viewed at the following web address:

<http://www.co.deschutes.or.us/administration/page/deschutes-county-code>

CONTRACT TIME

The Contractor shall complete all Work to be done under the Contract not later than August 31, 2024.

CLASS OF WORK

The Class of Work for this Project is Asphalt Concrete Paving and Oiling.

SECTION 00110 - ORGANIZATION, CONVENTIONS, ABBREVIATIONS AND DEFINITIONS

Comply with Section 00110 of the Standard Specifications modified as follows:

00110.05(e) Reference to Websites - Add the following bullet list to the end of this subsection:

- American Traffic Safety Services Association (ATSSA)
www.atssa.com
- Deschutes County Bids and RFPs website:
www.deschutescounty.gov/rfps
- ODOT Construction Section - Qualified Products List (QPL)
www.oregon.gov/ODOT/Construction/Pages/Qualified-Products.aspx
- ODOT Construction Surveying Manual for Contractors
www.oregon.gov/ODOT/ETA/Documents_Geometronics/Construction-Survey-Manual-Contractors.pdf
- ODOT Oregon Trucking Online - "Highway Restriction Notice - Size and/or Weight" (Form No. 734-2357)
www.oregontruckingonline.com/cf/MCAD/pubMetaEntry/restriction/
- ODOT Procurement Office - Construction Contracts Unit prequalification forms
www.oregon.gov/odot/business/procurement/pages/bid_award.aspx

00110.20 Definitions - Replace the definitions of the words and phrases list below with the following definitions:

Agency – County of Deschutes

Bid Booklet - The version that can be accessed and printed from the Deschutes County Bids and RFPs website, which contains the information identified in 00120.10.

Engineer - The Road Department Director of Deschutes County acting either directly or through his authorized representatives.

SECTION 00120 - BIDDING REQUIREMENTS AND PROCEDURES

Comply with Section 00120 of the Standard Specifications modified as follows:

00120.00 Prequalification of Bidders – Replace the last paragraph with the following:

Deschutes County Road Department will regularly evaluate the performance of Contractors on its projects for purposes of responding to reference checks, future prequalification and determinations of responsibility.

00120.01 General Bidding Requirements - Replace this subsection, except for the subsection number and title, with the following:

Bidders shall submit bids by paper.

The standard prequalification forms furnished by the ODOT Procurement Office shall be used by the bidder to file authorized signatures with Deschutes County Road Department. Signatures are of personnel authorized to submit Bids, modify Bids, or withdraw Bids.

00120.05 Request for Plans, Special Provisions, and Bid Booklets – Replace this subsection, except for the subsection number and title, with the following:

Bidders shall obtain solicitation documents from the Deschutes County Bids and RFPs website:

<https://www.deschutescounty.gov/rfps>

Each request shall include both the name of the person ordering or obtaining the Solicitation Documents, and the name of the Entity intending to use them. The Agency will add the name of the Entity intending to use the Solicitation Documents to the list of Holders of Bidding Plans. Bidders are cautioned that only Solicitation Documents obtained properly from the Deschutes County website may be used to submit Bids.

Only paper Bids will be accepted.

Copies of the Oregon Standard Specifications for Construction may be purchased or viewed online at:

http://www.oregon.gov/ODOT/Business/Pages/Standard_Specifications.aspx.

The Plans, which are applicable to the Work to be performed under the Contract, are bound herewith.

00120.10 Bid Booklet – Replace this subsection, except for the subsection number and title, with the following:

The Bidding Documents Booklet may include, but is not limited to:

- Cover Page
- Index
- Invitation to Bid
- Information for Bidders
- Bid Proposal Form
- Schedule of Bid Items
- Subcontractor Disclosure Form
- Bid Guaranty Form
- Contract Form (for review only)
- Payment and Performance Bond Forms (for review only)
- Certification of Workers' Compensation Coverage (for review only)

Depending on the Class of Project, other certificates or statements may be bound within the Bidding Documents Booklet. Plans, specifications, and other documents referred to in the Bidding Documents Booklet will be considered part of the Bid.

00120.15 Examination of Work Site and Solicitation Documents; Consideration of Conditions to be Encountered –

Replace the sentence that begins with “Any clarification of Plans and Specifications...” with the following:

Any clarification of Plans and Specifications needed by the Bidder shall be requested in writing through the Agency representative listed in the Information for Bidders contained in the Bidding Documents.

00120.30 Changes to Plans, Specifications, or Quantities before Opening of Bids –

Replace all instances of “ODOT eBIDS” with “Deschutes County Bids and RFPs”.

Delete the last paragraph.

00120.40(a)(1) Paper Bids – Replace all instances of “ODOT eBIDS” and “BidExpress” with “Deschutes County Bids and RFPs”.

00120.40(a)(2) Electronic Bids – Delete this subsection.

00120.40(c)(2) Electronic Bid Schedule Entries – Delete this subsection.

00120.40(d) Bidder’s Address and Signature Pages – Replace this subsection with the following:

Bidders shall include in the Bid the address to which all communication concerning the Bid and Contract should be sent. The Bid shall be signed by a duly authorized representative of the Bidder.

00120.40(e)(2) Bid Guaranty with Electronic Bids – Delete this subsection.

00120.40(f) Disclosure of First-Tier Subcontractors – Replace all instances of “ODOT eBIDS” and “BidExpress” with “Deschutes County Bids and RFPs”

Under the paragraph “The Subcontractor Disclosure Form may be submitted for a paper Bid...” replace the second bulleted item with the following:

- By removing it from the paper Bid Booklet, filling it out and submitting it separately to the Deschutes County Road Department at the address given in the Bid Booklet.

Delete the third bulleted item.

Delete the paragraph which begins “The Subcontractor Disclosure Form may be submitted for an electronic Bid by:”

Replace the paragraph that begins “Subcontractor Disclosure forms submitted by...” with the following:

Subcontractor Disclosure Forms submitted by any method will be considered late if not received by the Agency within two working hours of the time designated for receiving Bids.

00120.45 Submittal of Bids – Replace this subsection, except for the subsection number and title, with the following:

Bids shall be submitted in the manner and prior to the time listed in the Bidding Documents Booklet. Bids may be submitted by mail, parcel delivery service, or hand delivery. Bids submitted after the time set for receiving Bids will not be opened or considered. The Agency assumes no responsibility for the receipt and return of late Bids.

00120.50 Submitting Bids for More than One Contract – Delete this subsection.

00120.60(a) Paper Bids – Replace all references to “ODOT Procurement Office” with “Agency.”

Delete the third bullet point.

00120.60(b) Electronic Bids – Delete this subsection.

00120.70 Rejection of Nonresponsive Bids – Replace the bullet beginning with “The Bid is submitted on documents not obtained...” with the following bullet

- The Bid is submitted on documents not obtained directly from the Deschutes County Bids and RFPs website (see 00110.05(e)), or is submitted by a Bidder who is not registered on the Agency’s “Bid Documents/Plan Holders List”, as required by 00120.05.

Add the following bullet to the end of the bullet list:

- The Agency determines that any Pay Item is significantly unbalanced to the potential detriment of the Agency.

00120.95 Opportunity for Cooperative Arrangement – Delete this subsection.

SECTION 00130 – AWARD AND EXECUTION

Comply with Section 00130 of the Standard Specifications modified as follows:

00130.10 Award of Contract – Replace the paragraph that begins “The Agency will provide Notice of Intent...” with the following:

The Agency will provide Notice of Intent to Award on the Agency’s website at:

<https://www.deschutescounty.gov/rfps>

Delete the paragraph that begins “The Award will not be final until...”

00130.15 Right to Protest Award – Replace this subsection, except for the subsection number and title, with the following:

Adversely affected or aggrieved Bidders, limited to the three apparent lowest Bidders and any other Bidder directly in line for Contract Award, may submit to the Board of County Commissioners of Deschutes County a written protest of the Agency’s intent to Award within five working days following the Bid Opening. The protest shall specify the grounds upon which it is based.

The Agency will not consider late protests.

00130.50 Execution of Contract and Bonds:

(a) By the Bidder – In the sentence that begins “The successful Bidder...” replace “ODOT Procurement Office – Construction Contracts Unit” with “Agency”.

(b) By the Agency – In the sentence that begins “Within 7 Calendar Days...” replace “7” with “21 (twenty-one)”.

SECTION 00140 – SCOPE OF WORK

Comply with Section 00140 of the Standard Specifications.

SECTION 00150 - CONTROL OF WORK

Comply with Section 00150 of the Standard Specifications modified as follows:

00150.05 Cooperative Arrangements – Replace this subsection, except for the subsection number and title, with the following:

Agency is not, by virtue of this Contract, a partner or joint venturer with Contractor in connection with activities carried out under this Contract, and shall have no obligation with respect to Contractor's debts or any other liabilities of each and every nature.

00150.15(b) Agency’s Responsibilities - Replace this subsection, except for the subsection number and title, with the following:

The Engineer will:

- Provide up to three (3) copies of plans and specifications.
- Evaluate grade for acceptance at each course of material.
- Perform measurements and calculations for pay quantities.
- Perform final “as constructed” measurements.

00150.15(c) Contractor’s Responsibilities – Replace this subsection, except for the subsection number and title, with the following:

The Contractor shall:

- Layout and set construction stakes and marks to establish the lines, grades, Slopes, Cross Sections and curve super-elevations for Roadwork to construct the Project as shown and specified, by means approved by the Engineer.
- Make calculations, field notes and survey drawings for the layout and control of work as are necessary to construct the Project as specified.
- Provide original or copies of notes, calculations and drawings as requested.
- Preserve survey monuments and control stations as governed by applicable law.
- Establish control stations as necessary to control the Project.
- Replace and augment control stations as necessary to control the Project.
- Remove and dispose of all flagging, lath, stakes and other temporary staking material after the Project is completed.
- Protect from damage or disturbance any Utility that remains within the area in which Work is being performed. Maintain and re-establish location marks according to OAR 952-001-0090(3)(a). Coordinate re-establishment of the location marks with the associated Utility.
- Determine the exact location before excavating within the tolerance zone according to OAR 952-001-0090(3)(c);
- In addition to the notification required in OAR 952-001-0090(6), notify the Engineer and the Utility as soon as the Contractor discovers any previously unknown Utility conflicts or issues. Contrary to the OAR, stop excavating until directed by the Engineer and allow the Utility a minimum of two weeks to relocate or resolve the previously unknown Utility issues.

00150.30 Delivery of Notices – Delete the paragraph that begins with “Following Notice to Proceed, all notices and other documents...”

00150.50(f) Utility Information (No Anticipated Relocations) - Within the Project limits, there are no anticipated relocations with Utilities. The Contractor shall contact those Utilities having buried facilities and request that they locate and mark them for their protection prior to construction.

00150.60(a) Load and Speed Restrictions for Construction Vehicles and Equipment – Replace the first bullet with the following:

- The Contractor shall restrict loads and speeds as necessary to avoid displacement or loss of Materials on Subgrades and Aggregate Bases. Maximum speeds of construction equipment shall be limited to 25 mph unless otherwise approved by the Agency.

SECTION 00160 – SOURCE OF MATERIALS

Comply with Section 00160 of the Standard Specifications modified as follows:

00160.30 Agency-Furnished Materials – Add the following paragraph:

No Agency materials are being offered for use on this project. Contractor shall provide all required materials.

00160.40 Agency-Furnished Sources– Add the following paragraph:

No Agency sources are being offered for use on this project. Contractor shall provide all required materials.

SECTION 00165 - QUALITY OF MATERIALS

Comply with Section 00165 of the Standard Specifications modified as follows:

00165.03 Testing by Agency – Delete this subsection.

00165.04 Costs of Testing – Delete this subsection.

00165.10(a) Field-Tested Materials – Add the following sentence to the end of this subsection:

This is a Type D project.

00165.30(c) Acceptance of Field-Tested Materials – Replace the first sentence with the following:

The Agency may elect to verify the Contractor's test results for field-tested Materials according to the Quality Assurance Program in the MFTP.

00165.50(b)(1) Specification Materials – Delete the second sentence.

SECTION 00170 – LEGAL RELATIONS AND RESPONSIBILITIES

Comply with Section 00170 of the Standard Specifications modified as follows:

00170.08 Electronic Document Management - Delete this subsection.

Add the following subsection:

00170.09 Debt Limitation - This Contract is expressly subject to the debt limitation of Oregon counties set forth in Article XI, Section 10, of the Oregon Constitution, and is contingent upon funds being appropriated therefore. Any provision herein which would conflict with law are deemed inoperative to that extent.

00170.65(b)(1) Minimum Wage Rates – Replace the last two paragraphs in this subsection with the following:

The applicable prevailing wage rates for this project are the most recent version published by the Oregon Labor and Industries at the time the Project was initially advertised (Prevailing Wage Rates for Public Works Contracts, effective January 5, 2024). The wage rates can be found at the following web address:

<https://www.oregon.gov/boli/employers/Pages/prevailing-wage-rates.aspx>

00170.70(a) Insurance Coverages - Add the following to the end of this subsection:

The following insurance coverages and dollar amounts are required pursuant to this subsection:

Insurance Coverages	Combined Single Limit per Occurrence	Annual Aggregate Limit
Commercial General Liability	\$5,000,000	\$10,000,000
Commercial Automobile Liability	\$2,000,000	(aggregate limit not required)

(d) Additional Insured – Replace this subsection except for the subsection number and title with the following:

The liability insurance coverages of 00170.70(a) shall include an Additional Insured Endorsement endorsing the “Deschutes County, and its respective officers, agents, employees, and volunteers and the Deschutes County Board of Commissioners” as Additional Insureds, but only with respect to the Contractor's activities to be performed under the Contract. Coverage shall be primary and non-contributory with any other insurance and self-insurance. The liability coverages of 00170.70(a) that are permitted by the Agency to be obtained by an appropriate Subcontractor shall include all of the foregoing as Additional Insureds and shall also include the Contractor and its officers and employees as Additional Insureds.

Additional Insured Endorsements on the Commercial General Liability shall be written on ISO Form CG 20 10 07 04, or equivalent, with respect to liability arising out of ongoing operations and ISO Form CG 20 37 07 04, or equivalent, with respect to liability arising out of completed operations. Additional Insured Endorsements shall be submitted with the Certificate(s) of Insurance and must be acceptable to the Agency.

Add the following as Additional Insureds under the Contract:

- Deschutes County and its officers, agents, employees, and volunteers
- Deschutes County Board of Commissioners

(g) Certificate(s) of Insurance - Replace this subsection except for the subsection number and title with the following:

As evidence of the insurance coverages required by the Contract, the Contractor shall furnish Certificate(s) of Insurance to the Agency at the time(s) provided in 00130.50(a). As evidence of insurance coverages required by the Contract but permitted by the Agency under 00170.70(a) to be obtained by an appropriate Subcontractor, the Contractor shall furnish Certificate(s) of Insurance to the Agency for such coverages together with the Contractor's request under 00180.21 for approval of the subcontract with that Subcontractor. The Certificate(s) shall:

- List “Deschutes County and its officers, agents, employees, and volunteers and the Deschutes County Board of Commissioners” as a Certificate holder and endorse as an Additional Insured;
- Include all required endorsements or copies of the applicable policy language effecting coverage required by the Contract;

- Specify that all liability insurance coverages shall be primary and non-contributory with any other insurance and self-insurance, with exception of Workers' Compensation;
- Include a list of all policies that fall under the Excess/Umbrella Insurance if Excess or Umbrella Insurance is used to meet the minimum insurance requirement.
- Be endorsed with a waiver of subrogation endorsement for Workers' Compensation, waiving the insured's right of subrogation against the Agency.

00170.72 Indemnity/Hold Harmless - Add the following paragraph and bullets to the end of this subsection:

Extend indemnity and hold harmless to the Agency and the following:

- Deschutes County and its officers, agents, and employees
- Deschutes County Board of Commissioners

SECTION 00180 – PROSECUTION AND PROGRESS

Comply with Section 00180 of the Standard Specifications modified as follows:

00180.40(c) Specific Limitations - Limitations of operations specified in these Special Provisions include, but are not limited to, the following:

Limitations	Subsection
Cooperation with Utilities	00150.50
On-Site Work	00180.40(b)
Contract Time	00180.50(h)
Right-of-Way and Access Delays	00180.65
Closed Lanes	00220.40(e)(1)
Noise Control	00290.32
Maintenance Under Traffic	00620.43
Opening Sections to Traffic	00744.51

The Contractor shall be aware of and subject to schedule limitations in the Standard Specifications that are not listed in this subsection.

00180.41 Project Work Schedules - After the paragraph that begins "One of the following Type..." add the following paragraph:

In addition to the "look ahead" Project Work schedule, a Type A schedule as detailed in the Standard Specifications is required on this Contract.

00180.50(h) Contract Time - The Contractor shall complete all Work to be done under the Contract not later than August 31, 2024.

SECTION 00190 – MEASUREMENT OF PAY QUANTITIES

Comply with Section 00190 of the Standard Specifications.

SECTION 00195 - PAYMENT

Comply with Section 00195 of the Standard Specifications modified as follows:

00195.12(d) Steel Materials Pay Item Selection - Add the following to this subsection:

No Pay Items under this Contract qualify for the steel escalation/de-escalation program for this Project.

00195.50(b) Retainage – Replace the first paragraph of this subsection with the following:

The Agency reserves the right in its sole discretion to not withhold retainage from progress payments or to begin withholding retainage at any time. If the Agency withholds retainage from progress payments, the amount to be retained from progress payments will be 5% of the value of Work accomplished, and will be retained in one of the forms specified in Subsection (c) below. No retainage will be withheld from Work performed as Force Account Work, escalation/de-escalation, bonuses, or other items decided by the Agency.

00195.50(c)(2) Cash, Alternate B (Retainage Surety Bond) - Delete this subsection.

00195.50(c)(3) Bonds, Securities and Other Instruments – Delete this subsection.

00195.50(d) Release of Retainage – Replace this subsection with the following:

As the Work progresses, release of the amounts retained under (b) above will only be considered for Pay Items that have been satisfactorily completed. For purposes of this Subsection, a Pay Item will be considered satisfactorily completed only if all of the Work for the Pay Item is complete and all contractual requirements pertaining to the Pay Item and Work have been satisfied. Work not included in a Pay Item, or which constitutes part of an uncompleted Pay Item, will not be regarded as satisfactorily completed Work for the purposes of this Subsection.

A determination of satisfactory completion of Pay Items or Work or release of retainage shall not be construed as acceptance or approval of the Work and shall not relieve the Contractor of responsibility for defective Materials or workmanship or for latent defects and warranty obligations.

The Contractor shall comply with all applicable legal requirements for withholding and releasing retainage and for prompt payments, including but not limited to those in ORS Chapters 279C and 701, and 49 CFR 26.29.

SECTION 00196 – PAYMENT FOR EXTRA WORK

Comply with Section 00196 of the Standard Specifications.

SECTION 00197 – PAYMENT FOR FORCE ACCOUNT WORK

Comply with Section 00197 of the Standard Specifications.

SECTION 00199 - DISAGREEMENTS, PROTESTS, AND CLAIMS

Comply with Section 00199 of the Standard Specifications modified as follows:

00199.40 Claim Decision; Review; Exhaustion of Administrative Remedies – Replace the second and third paragraphs with the following:

If the Engineer denies the claim for additional compensation or a combination of additional compensation and Contract Time, in full or in part, according to 00199.40(a), the Contractor may request review of the denial. The disputed claim may then be resolved, in full or in part, at any of the three progressive steps of claim review procedure as set forth in (b) through (d) of this Subsection.

If the Engineer has denied a claim, in full or in part, for Contract Time only according to 00180.80, or has denied a claim, in full or in part, for correction of final compensation according to 00195.95, those disputed claims may then be resolved, in full or in part, at any of the three progressive steps of claim review procedure as specified in (b) through (d) of this Subsection.

Delete the fifth paragraph.

00199.40(b-e) - Replace these subsections in their entirety with the following:

00199.40(b) Step 1: Board of Commissioners Review – The Contractor shall request that the Engineer arrange for a hearing during a regularly scheduled Board of Commissioners Meeting in order to present the denied or partially denied claim for formal review and discussion. The meeting will take place within 21 Calendar Days of the Agency's receipt of the request, or as otherwise agreed by the parties.

If the Board of Commissioners determines that the Contractor must furnish additional information or documentation to allow proper analysis of the claim, the Engineer will prepare a Board meeting agenda item for a second hearing within 14 Calendar Days, or as otherwise agreed by the parties, at which the Contractor shall present the requested information or documentation.

If the Contractor does not accept the Step 1 decision, the Contractor may, within 10 Calendar Days of receipt of the written decision, request in writing through the Engineer that the claim be advanced to Step 3 or 4 (see (c) and (d) below.

00199(c) Step 2: Arbitration - At this step, the claim will be resolved by binding arbitration before a single arbitrator according to the Construction Industry Arbitration Rules of the American Arbitration Association or such other arbitration service and rules as agreed by the parties.

Arbitration filing costs and any arbitrator's fees will be divided equally between the Agency and the Contractor.

00199(d) Step 3: Litigation – This step applies to appeals of arbitration awards issued in Step 2 at 00199.40(c) above, according to ORS 36.600 through ORS 36.740.

The Contractor must follow each step in order, and exhaust all available administrative remedies before resorting to litigation. Lawsuits must be properly filed in a court of competent jurisdiction

within 6 months from the date of the final decision that exhausted the Contractor's available administrative remedies under this Section 00199.

The Contractor shall comply with 00170.00.

SECTION 00210 - MOBILIZATION

Comply with Section 00210 of the Standard Specifications.

SECTION 00220 - ACCOMMODATIONS FOR PUBLIC TRAFFIC

Comply with Section 00220 of the Standard Specifications modified as follows:

00220.02(a) General Requirements - Add the following bullet to the end of the bullet list:

- When paving operations create an abrupt edge, protect traffic by installing a "DO NOT PASS" (R4-1) sign before the Work Area at sign spacing "A" from the TCD Spacing Table" shown on the Standard Drawings. Alternate "ABRUPT EDGE" (CW21-7) signs with appropriate (CW21-8) rider and "DO NOT PASS" (R4-1) signs at 1/2 mile spacings. Install a "BUMP" (W8-1) sign 100 feet prior to the transverse paving edge.

00220.02(b) Temporary Pedestrian Accessible Route Plan - Add the following bullet to the end of the bullet list:

- For an active Work Area controlled at each end by flaggers and pilot car, provide transportation for pedestrians and bicyclists through the active Work Area according to Section 00223 and Section 00228.

00220.02(c) Bicyclists - Add the following to the end of the bulleted list:

- During flagging and pilot car operations, allow bicycles to clear the work zone before allowing oncoming traffic to enter the work zone.

00220.40(e)(1) Closed Lanes - Replace this subsection, except for the subsection number and title, with the following:

One Traffic Lane may be closed when allowed, shown, or directed during the following periods of time except as indicated in 00220.40(e)(2):

- Daily, Monday through Friday between 7:00 a.m. and 6:00 p.m.

The length of the Work Zone shall not exceed 1 mile without prior approval from the Engineer.

SECTION 00221 - COMMON PROVISIONS FOR WORK ZONE TRAFFIC CONTROL

Comply with Section 00221 of the Standard Specifications modified as follows:

00221.06 Traffic Control Plan - Replace this subsection with the following subsection:

00221.06 Traffic Control Plan and Tourist-Oriented Directional and Business Logo Signs –

(a) Traffic Control Plan - Submit one of the following, 5 Calendar Days before the preconstruction conference:

(1) Agency Traffic Control Plan - If the Contractor intends to use the Agency TCP without modification, a written notification indicating that the Agency TCP will be used without modification.

(2) Contractor-Modified Traffic Control Plan - The Contractor may request to use a Contractor-modified Agency TCP, or a TCP developed by the Contractor. Do not use a modified TCP, or a TCP developed by the Contractor, unless approved by the Engineer. Use the Agency TCP unless a modified TCP, or a TCP developed by the Contractor is accepted.

The Engineer is not obligated to consider any modified Agency TCP or a TCP developed by the Contractor. The Agency will not be liable to the Contractor for failure to accept or act upon any request for a modified Agency TCP or a TCP developed by the Contractor.

To conserve time and funds, the Contractor may first submit a written request for a preliminary review by the Engineer. The request should contain a description of the proposal together with a rough estimate of anticipated dollar and time impacts. The Engineer will, within a reasonable time, respond to the Contractor in writing whether or not the request would be considered by the Agency.

If requesting a Contractor-modified Agency TCP, or a TCP developed by the Contractor, at a minimum the request shall meet all requirements of the Contract documents and comply with the Project transportation management plan (TMP). Provide the following information:

Stamped Working Drawings according to 00150.35 that include the proposed TCP showing all TCM and quantities of TCD.

A TPAR plan that includes:

- Details and features used to provide pedestrian accessibility.
- Pedestrian staging Plans at a scale no smaller than 1 inch = 50 feet.
- Temporary alternate facilities or detour routes for pedestrian traffic.
- Staging sequences and details for Work affecting vehicular, pedestrian, and bicycle traffic.
- Proposed order and duration of the TCM.
- A detailed temporary striping plan.

If the Contractor's request to use a Contractor-modified Agency TCP, or a TCP developed by the Contractor is approved in whole or in part, acceptance will be made by a Change Order.

The Engineer will establish prices that represent a fair measure of the value of Work to be added, changed, or deleted as a result of any accepted modifications to the Agency TCP or an accepted TCP developed by the Contractor.

Once a TCP has been accepted by the Engineer, any additional modifications must be submitted by the Contractor for Agency review following the procedure described above. The Engineer is not obligated to consider additional modifications to a previously approved TCP.

(b) Tourist-Oriented Directional and Business Logo Signs - Submit one of the following for approval, at least 5 Calendar Days before the preconstruction conference:

(1) No Signs - If there are no tourist-oriented directional (TOD) or business logo signs on the Project, a written notification that no TOD or business logo signs exist within the Project limits or

(2) Signs - Submit one copy of a sketch map of the Project showing all existing TOD and business logo signs and a written narrative describing how these signs will be kept in service and protected throughout all the construction stages. If modifications are necessary, submit updated information to the Engineer for approval at least 21 Calendar Days before the change is needed.

00221.90(b) Temporary Protection and Direction of Traffic – Add the following to the end of the bullet list:

- Furnishing, installing, maintaining and removing temporary flexible pavement markers.

SECTION 00222 – TEMPORARY TRAFFIC CONTROL SIGNS

Comply with Section 00222 of the Standard Specifications modified as follows:

00222.40(e) Temporary Sign Placement - Add the following to the end of the bullet list:

- Install "ROAD WORK AHEAD" (W20-1-48) signs with a 36 by 24-inch "FINES DOUBLE" (R2-6aP) rider at the locations identified in the Plans.
- Place the signs according to the "TCD Spacing Table" shown on the Standard Drawings or as modified by the Plans except do not install the "FINES DOUBLE" rider on concrete barrier mounted signs.
- Install beyond each end of the Project, facing outgoing traffic, an "END ROAD WORK" (CG20-2A-24) sign a distance of $(A \div 2)$ according to the "TCD Spacing Table" shown on the Standard Drawings or as modified by the Plans.
- When construction requires bicycles to use the Traffic Lanes, install a "Bicycle ON ROADWAY" (CW11-1) symbol sign as shown or directed through the affected area. Keep the signs in place until completion of the Shoulder or bikeway final surface.
- Install a "Bicycle ON ROADWAY" (CW11-1) symbol sign and a 24 by 18-inch "NEXT XX MILES" (W7-3aP) plaque according to "Sign Spacing A", from the "TRAFFIC CONTROL DEVICES SPACING TABLE" shown on the Standard Drawings, after the "ROAD WORK AHEAD" sign. Install a "Bicycle ON ROADWAY" symbol sign on 1 mile spacing through the

affected area. Keep the signs in place until completion of the Shoulder or bikeway final surface.

- Install a 72 by 24-inch "CONSTRUCTION VEHICLE DO NOT FOLLOW" (CW23-14) sign on rigid substrate on the back of all Material or Equipment delivery vehicles.
- Within the limits of active pilot car operations install a 15 by 24-inch "WAIT FOR PILOT CAR" (CR4-20) sign at stop-controlled side roads and public accesses intersecting Old Bend-Redmond Hwy / South Canal Blvd when the intersection operations are not under the control of a certified flagger.
- Within the limits of active pilot car operations install a 12 by 12-inch "WAIT FOR PILOT CAR" (CR4-20a) sign in private residential driveways accessing Old Bend-Redmond Hwy/ South Canal Blvd. Place the sign in the driveway facing the private residence and so the sign face is not visible to Public Traffic on the Highway. Do not use the sign for apartments, condominiums or business accesses.
- At accesses, side roads, or residential driveways where "WAIT FOR PILOT CAR" (CR4-20) signs are installed, do not allow traffic to be stopped or held for longer than 20 minutes.
- In addition to the signs, public notification (e.g. flyers, door hangers) may be used to inform the residents that may be affected by the pilot car operations and the "WAIT FOR PILOT CAR" signs.
- For each location of the "WAIT FOR PILOT CAR" sign, closely monitor for traffic compliance, operation, and safety at least once per hour during pilot car operations. If operational issues are observed, or if notified of operational issues, at stop-controlled accesses or side roads utilizing the "WAIT FOR PILOT CAR" (CR4-20) sign, remove the sign and replace it with a flagger.

00222.80(a) Area Basis - Add the following to the end of the paragraph that begins "Temporary signs will...":

No measurement of quantities will be made for "CONSTRUCTION VEHICLE DO NOT FOLLOW" (CW23-14) signs.

No measurement of quantities will be made for "WAIT FOR PILOT CAR" (CR4-20) or (CR4-20a) signs.

00222.90 Payment - Add the following to the end of the paragraph that begins "No separate or...":

No separate or additional payment will be made for furnishing, installing, and maintaining 72 by 24-inch "CONSTRUCTION VEHICLE DO NOT FOLLOW" (CW23-14) signs. Payment will be included in 00221.90(b).

No separate or additional payment will be made for furnishing, installing, and maintaining "WAIT FOR PILOT CAR" (CR4-20) or (CR4-20a) signs. Payment will be included in 00221.90(b).

SECTION 00223 - WORK ZONE TRAFFIC CONTROL LABOR AND VEHICLES

Comply with Section 00223 of the Standard Specifications modified as follows:

00223.31(b) Traffic Control Inspection Without TCS – Replace the bullet that begins with "Prepares and signs..." with the following bullet.

- Prepares and signs a "Traffic Control Inspection Report" on the approved form furnished by the Agency upon the initial installation of TCM and each working day when any modification, removal, or reinstallation of TCM are made, or as directed by the Engineer. Submit completed reports to the Engineer no later than the end of the next working day.

SECTION 00224 - TEMPORARY TRAFFIC CHANNELIZING DEVICES

Comply with Section 00224 of the Standard Specifications.

SECTION 00225 - TEMPORARY PAVEMENT MARKINGS

Comply with Section 00225 of the Standard Specifications modified as follows:

00225.80 Measurement – Replace this section, except for the subsection number and title, with the following:

No measurement will be made for work performed under this section.

00225.90 Payment – Replace this subsection, except for the subsection number and title, with the following:

Work performed under this section will be paid for according to 00221.90(b).

SECTION 00228 - TEMPORARY PEDESTRIAN AND BICYCLIST ROUTING

Comply with Section 00228 of the Standard Specifications.

SECTION 00290 - ENVIRONMENTAL PROTECTION

Comply with Section 00290 of the Standard Specifications modified as follows:

00290.20(c)(3)(a) Burnable Materials – Delete this subsection.

00290.20(c)(3)(b) Woody Matter – Replace this subsection, except for the subsection number and title, with the following:

Woody matter may be chipped to a size of no more than 3 inches in any direction then uniformly spread over selected landscape areas, as directed, in loose layers not more than 3 inches thick. Burying or burning wood, stumps, or other woody material is not allowed.

00290.30(c)(3) Burn Restrictions – Delete this subsection.

00290.32 Noise Control - Add the following paragraph to the end of this subsection:

Review Deschutes County Code Title 8.08 which describes noise control regulations. Obtain and be responsible for necessary permits described in Deschutes County Code Title 8.08. Comply with the applicable noise control requirements for Project Work.

SECTION 00620 - COLD PLANE PAVEMENT REMOVAL

Comply with Section 00620 of the Standard Specifications modified as follows:

00620.43 Maintenance Under Traffic - Replace this subsection, except for the subsection number and title, with the following:

Traffic is not allowed on the cold planed surface. Before opening the area to traffic, pave the surface according to 00744.51.

SECTION 00640 - AGGREGATE SUBBASE, BASE, AND SHOULDERS

Comply with Section 00640 of the Standard Specifications modified as follows:

00640.41 Mixing, Hauling, and Placing – Add the following to the end of this subsection:

Place aggregate shoulder material with equipment that is capable of maintaining a consistent shoulder cross slope and width, and without casting material beyond the ordinary limits of the aggregate shoulder as shown in the Plans.

00640.80 Measurement – Add the following to the end of this subsection:

Aggregate shoulder material which is placed or cast beyond the ordinary limits of the aggregate shoulder as shown in the Plans will be deducted from the total ticket quantity based on visual estimation by the Engineer.

00640.90 Payment – Add the following to the end of this subsection:

No payment will be made for aggregate shoulder material which is placed or cast beyond the ordinary limits of the aggregate shoulder according to 00640.80.

SECTION 00730 - EMULSIFIED ASPHALT TACK COAT

Comply with Section 00730 of the Standard Specifications modified as follows:

00730.23 Power Brooms – Provide pickup and non-pickup type power brooms equipped with a positive means to control vertical pressure.

00730.42 Preparation of Underlying Surfaces – Add the following to the end of this subsection:

Carefully broom the entire surface to be tacked to remove loose Material that could inhibit tack coat bonding. Use a minimum of two power brooms. In curbed areas or in areas of cold plane pavement removal, use a pickup type power broom.

Pavement surface shall be cleaned to the apparent existing edge of pavement.

Perform additional passes with a power broom as directed. Application of tack coat shall not commence until surface cleanliness has been verified and approved by the Engineer.

00730.44 Applying Tack Coat - Apply the Emulsified Asphalt with a pressure distributor conforming to 00730.22, unless otherwise allowed. Apply the Emulsified Asphalt to the prepared surface at a rate between 0.05 and 0.20 gallons per square yard as directed and with the Emulsified Asphalt temperature between 140 °F and 185 °F as recommended by the manufacturer. Refer to the manufacturer's recommendations for tack coat application rates for the underlying surface type and type of emulsion used. Application rates for tack coat diluted according to 00730.11 will be increased as necessary to provide the same amount of residual asphalt as the application rates specified above.

Do not place hot mixed asphalt concrete Pavement or Emulsified Asphalt Concrete Pavement on the tack coat until the Emulsified Asphalt separates from the water (breaks), but before it loses its tackiness. Refer to manufacturer recommendations regarding break/set time. Minimize truck traffic on the tacked surface.

00730.90 Payment - Replace this subsection, except for the subsection number and title, with the following:

No separate or additional payment will be made for Emulsified Asphalt tack coat. Approximately 49 Tons of Emulsified Asphalt in tack coat will be required on this Project.

SECTION 00744 - ASPHALT CONCRETE PAVEMENT

Comply with Section 00744 of the Standard Specifications modified as follows:

00744.11(a) Asphalt Cement - Add the following to the end of this subsection:

Provide PG 58-34ER grade asphalt cement for this Project.

Add the following subsection:

00744.51 Opening Sections to Traffic - Schedule work so that, during the same shift, the surfaces being paved are paved full width and length through the wearing Course before opening to traffic.

SECTION 00748 - ASPHALT CONCRETE PAVEMENT REPAIR

Comply with Section 00748 of the Standard Specifications.

SECTION 00749 - MISCELLANEOUS ASPHALT CONCRETE STRUCTURES

Comply with Section 00749 of the Standard Specifications modified as follows:

00749.14 Concrete - Delete this subsection.

SECTION 00840 – DELINEATORS AND MILE MARKER POSTS

Comply with Section 00840 of the Standard Specifications

SECTION 00850 - COMMON PROVISIONS FOR PAVEMENT MARKINGS

Comply with Section 00850 of the Standard Specifications modified as follows:

00850.45 Installation – Add the following to the end of this subsection:

Do not place liquid thermoplastic striping materials within one week of a rainfall event without prior written approval from the Engineer.

SECTION 00855 - PAVEMENT MARKERS

Comply with Section 00855 of the Standard Specifications.

SECTION 00865 - LONGITUDINAL PAVEMENT MARKINGS - DURABLE

Comply with Section 00865 of the Standard Specifications.

SECTION 00867 - TRANSVERSE PAVEMENT MARKINGS - LEGENDS AND BARS

Comply with Section 00867 of the Standard Specifications.

###

DESCHUTES COUNTY ROAD DEPARTMENT

PLANS FOR

PAVING OF OLD BEND REDMOND HWY / S CANAL BLVD: TUMALO RD to SW HELMHOLTZ WAY

APRIL 2024

INDEX OF SHEETS

Sheet #	Description
1	COVER SHEET
2	TYPICAL SECTION
3	DETAILS
4	DETAILS
5	PLAN---STA 1+00 To 16+00
6	PLAN---STA 16+00 To 31+00
7	PLAN---STA 31+00 To 46+00
8	PLAN---STA 46+00 To 61+00
9	PLAN---STA 61+00 To 71+00
10	PLAN---STA 71+00 To 86+00
11	PLAN---STA 86+00 To 101+00
12	PLAN---STA 101+00 To 116+00
13	PLAN---STA 116+00 To 131+00
14	PLAN---STA 131+00 To 146+00
15	PLAN---STA 146+00 To 161+00
16	PLAN---STA 161+00 To 176+00
17	PLAN---STA 176+00 To 191+00
18	PLAN---STA 191+00 To 206+00
19	PLAN---STA 206+00 To 221+00
20	PLAN---STA 221+00 To 236+00
21	PLAN---STA 236+00 To 251+00
22	PLAN---STA 251+00 To 266+00
23	PLAN---STA 266+00 To 281+00
24	PLAN---STA 281+00 To END
25	TEMPORARY TRAFFIC CONTROL PLAN
26	TEMPORARY TRAFFIC CONTROL PLAN

OREGON STANDARD DRAWING NO.

TM500	PAVEMENT MARKING STD DETAIL BLOCKS
TM502	PAVEMENT MARKING STD DETAIL BLOCKS
TM503	PAVEMENT MARKING STD DETAIL BLOCKS
TM517	RECESSED PAVEMENT MARKERS
TM530	INTERSECTION PACEMENT MARKINGS
TM560	ALIGNMENT LAYOUT: GENERAL
TM570	TRAFFIC DELINEATORS
TM571	TRAFFIC DELINEATORS STEEL POST DETAILS
TM800	TABLES, ABRUPT EDGE AND PCMS DETAILS
TM821	TEMPORARY SIGN SUPPORTS
TM822	TEMPORARY SIGN SUPPORTS
TM850	2-LANE, 2-WAY ROADWAYS
TM855	2-LANE, 2-WAY ROADWAYS

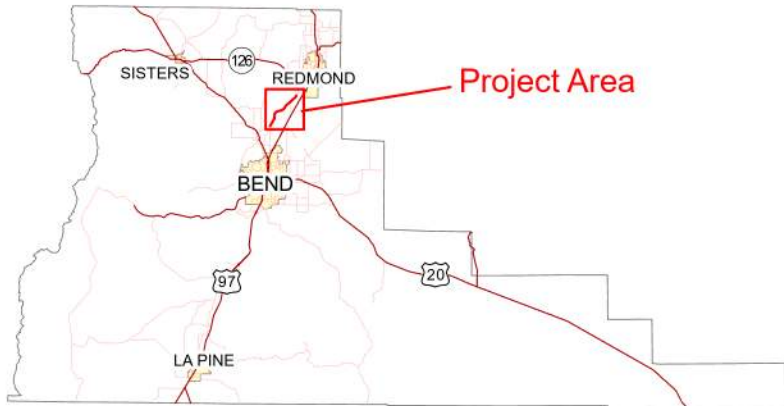

LOCATION MAP

NOT TO SCALE

	Bridges		Road Centerlines
	Project Centerline		State Highway
	County Routes		Streams
			Canals



ROAD DEPARTMENT

TITLE:
COVER SHEET

SHEET NO:
1 of 26

DATE:
3/27/24

SCALE:
N.T.S.

DRAFTER: R. PINKSTON
REVIEWED BY: C. SMITH

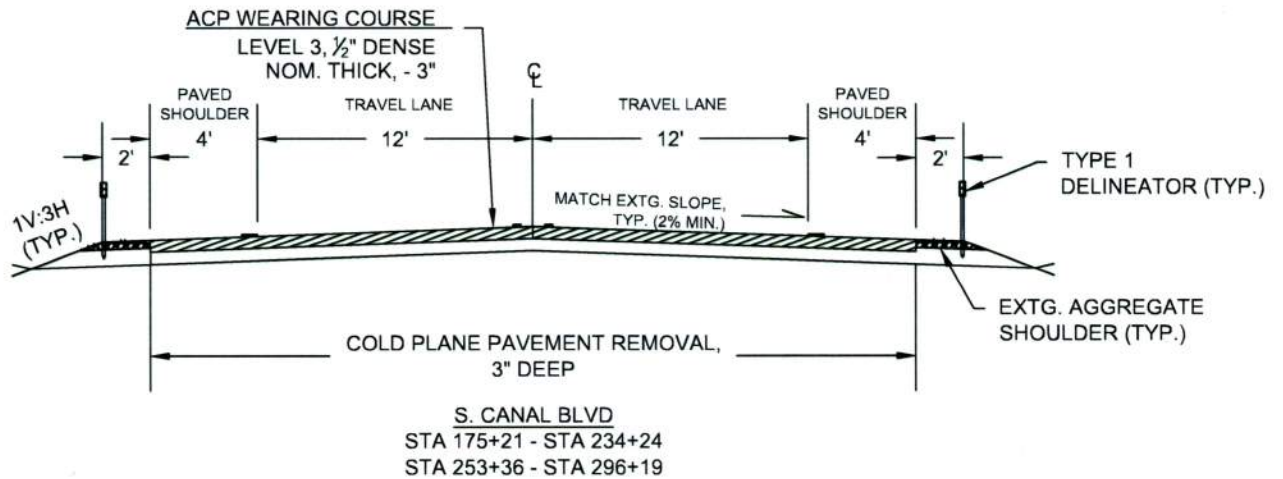
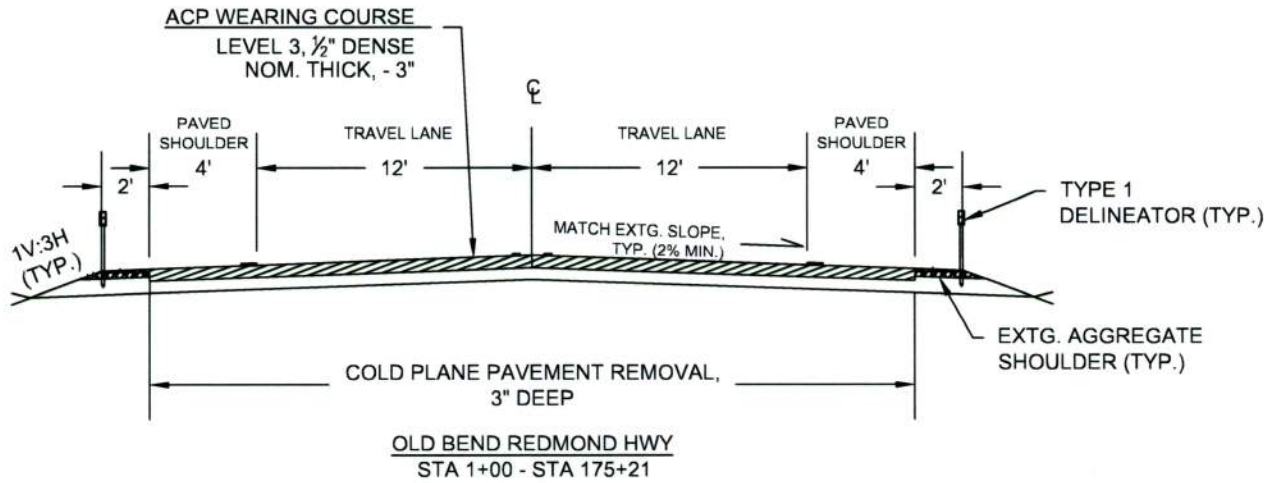

NOTES

- 1) PAVED SHOULDER WIDTH MAY VARY.
- 2) TYPE 1 DELINEATORS INSTALLED PER PLANS OR AS DIRECTED.
- 3) REPAIR EXISTING AGGREGATE SHOULDERS AS DIRECTED.
- 4) SEE SHEET 4 FOR LONGITUDINAL JOINT OFFSET DETAIL.



RENEWS 6/30/2024



ROAD DEPARTMENT

PLAN: TYPICAL SECTION		SHEET NO.: 2 OF 26
DATE: 3/27/24	SCALE: H: 1" = 8' V: N.T.S	APPROVED BY: C. SMITH

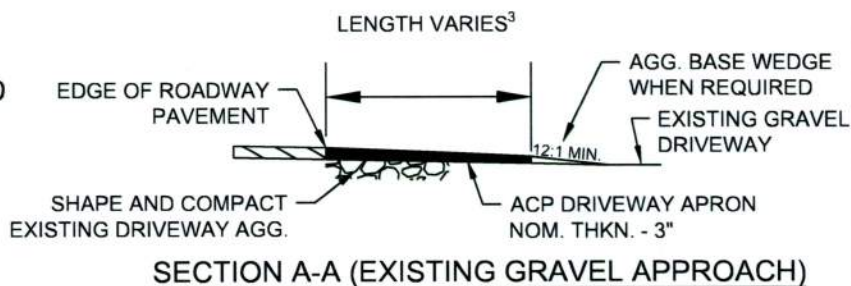
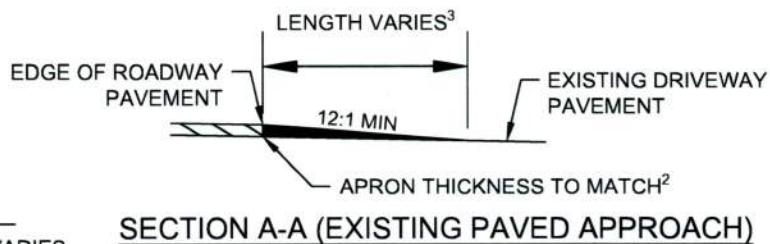
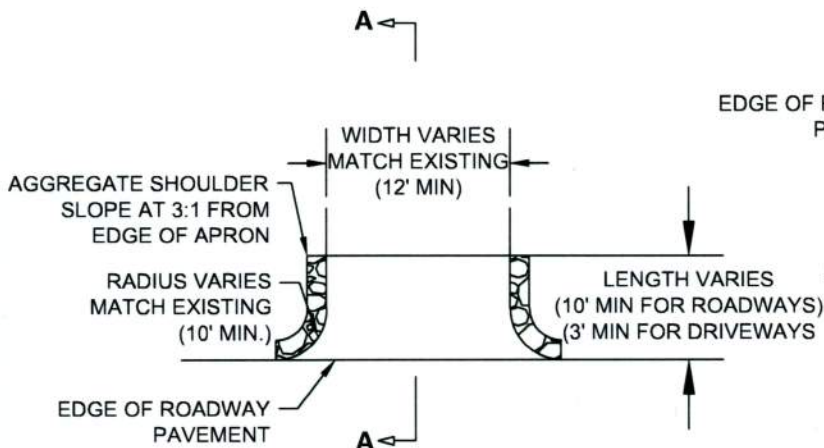
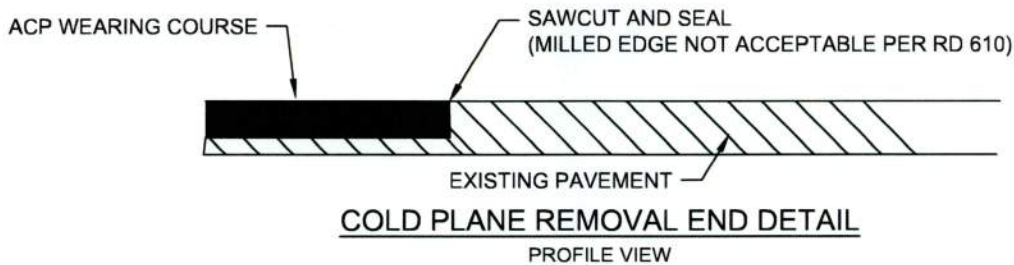

NOTES

- 1) DRIVEWAY APPROACHES ARE CONSIDERED MINOR APPROACHES UNLESS OTHERWISE APPROVED BY ENGINEER.
- 2) ACP FOR INTERSECTION APPROACH AND DRIVEWAY APRONS MATCH ROADWAY ACP THICKNESS AT EDGE OF ROADWAY. FEATHER TO MIN. ACHIEVABLE THICKNESS OVER LENGTH OF APRON.
- 3) 10' MIN FOR ROADS, 3' MIN FOR DRIVES



RENEWS: 6/30/2024



ROAD DEPARTMENT

PLAN: DETAILS		SHEET NO.: 3 OF 26
DATE: 3/27/24	SCALE: N.T.S.	APPROVED BY: C. SMITH

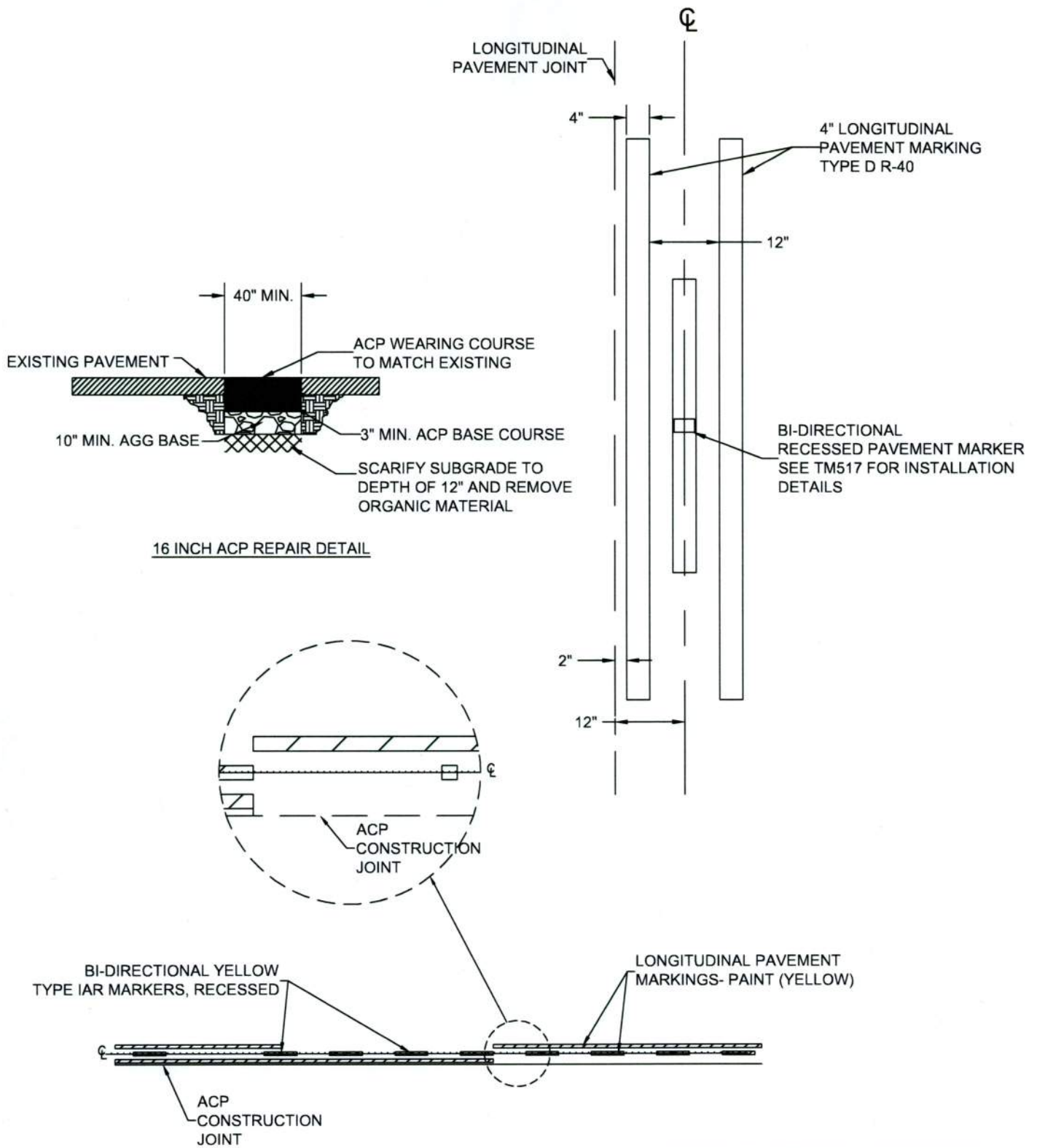

NOTES

- 1) ACP REPAIR LIMITS WILL BE FIELD MARKED IN ADVANCE OF CONSTRUCTION.
- 2) COMPACT SUBGRADE TO UNYIELDING CONDITION.
- 3) APPLY EMULSIFIED ASPHALT TACK COAT TO VERTICAL EDGES OF EXISTING ASPHALT SURFACING.
- 4) FOR PAVEMENT MARKING DETAILS NOT SHOWN, SEE TM500 THROUGH 503.



RENEWS: 6/30/2024



ROAD DEPARTMENT

PLAN: DETAILS		SHEET NO.: 4 OF 26
DATE: 4/2/24	SCALE: N.T.S.	APPROVED BY: C. SMITH

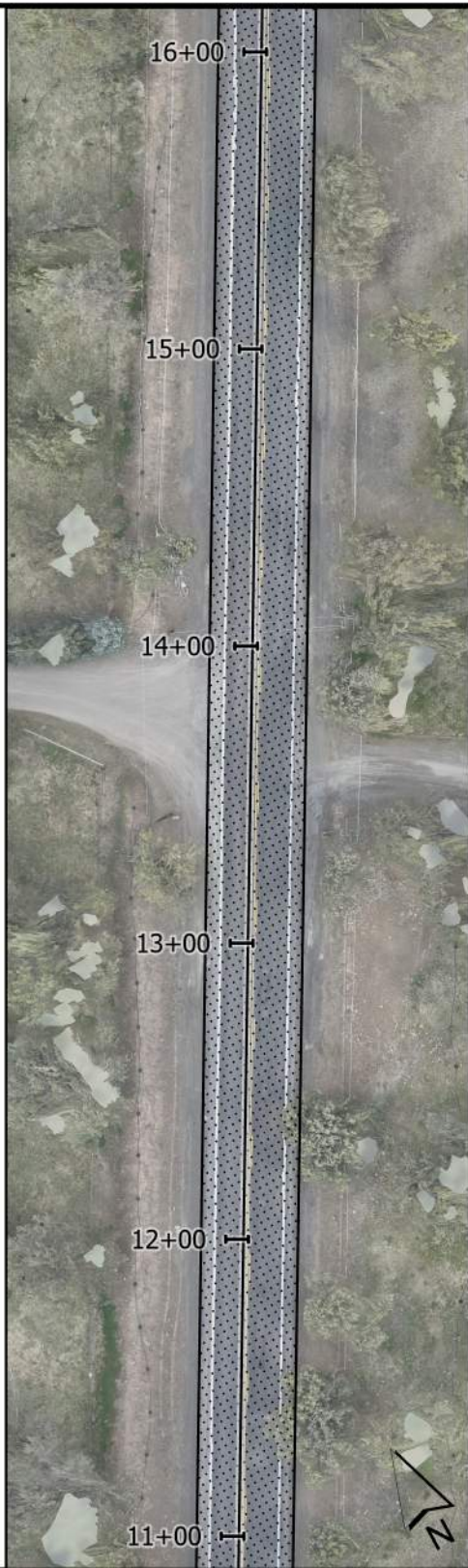
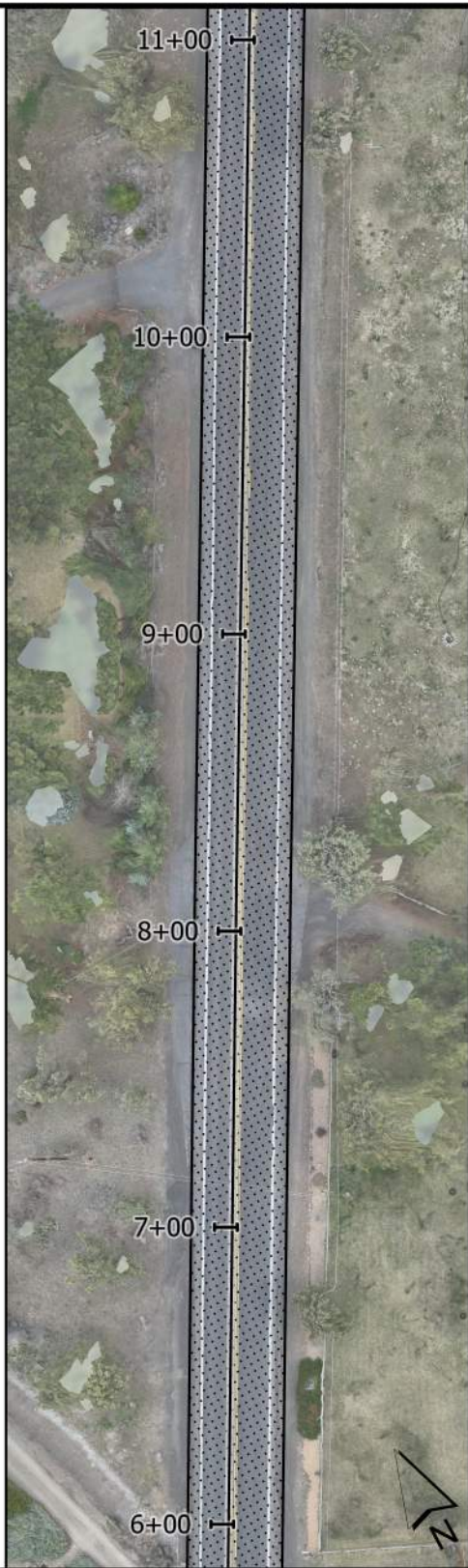
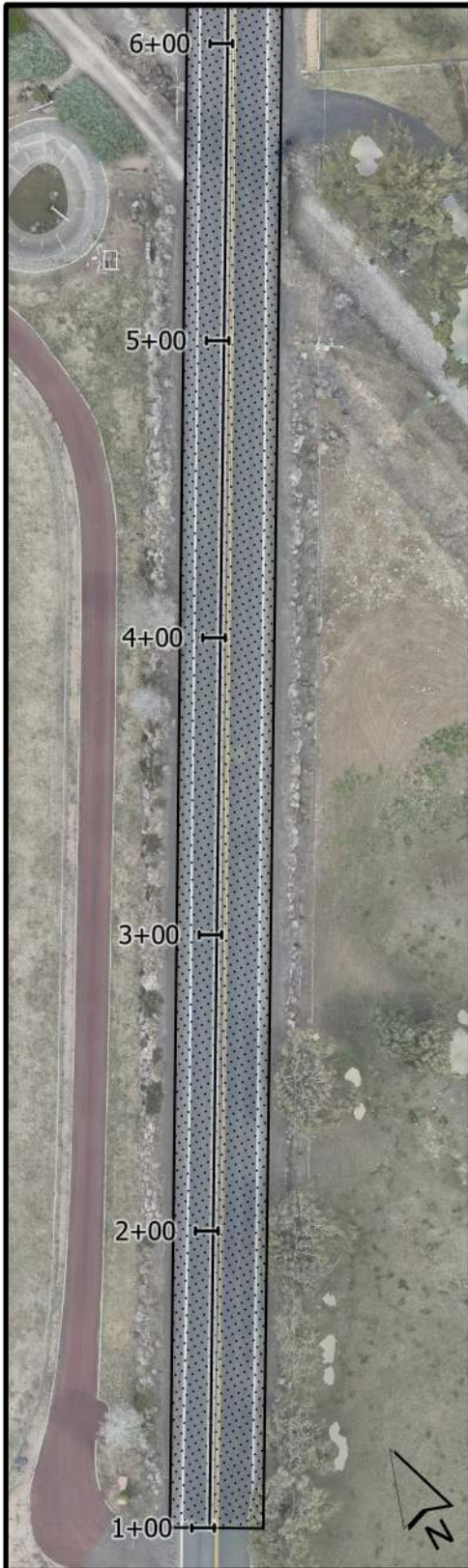

LEGEND

 3" INLAY, FULL-WIDTH
(SEE TYPICAL SECTION, SHEET 2)

NOTES:

PERFORM ACP REPAIR AS DIRECTED PRIOR TO CONSTRUCTING INLAY.

INSTALL THERMOPLASTIC CENTERLINE STRIPING WITH TYPE IAR RECESSED PAVEMENT MARKERS ACCORDING TO EXISTING LAYOUT.

INSTALL THERMOPLASTIC EDGE LINE STRIPING, TYPE W-2.

INSTALL STOP BAR, TYPE S AND STOP/STOP AHEAD LEGENDS AS SHOWN.

INSTALL TYPE 1 DELINEATORS AT FIELD-MARKED LOCATIONS.



ROAD DEPARTMENT

PLAN:
STA 1+00 to 16+00

SHEET NO:
5 of 26

DATE:
3/27/24

SCALE:
N.T.S.

DRAFTER: R. PINKSTON
REVIEWED BY: C. SMITH

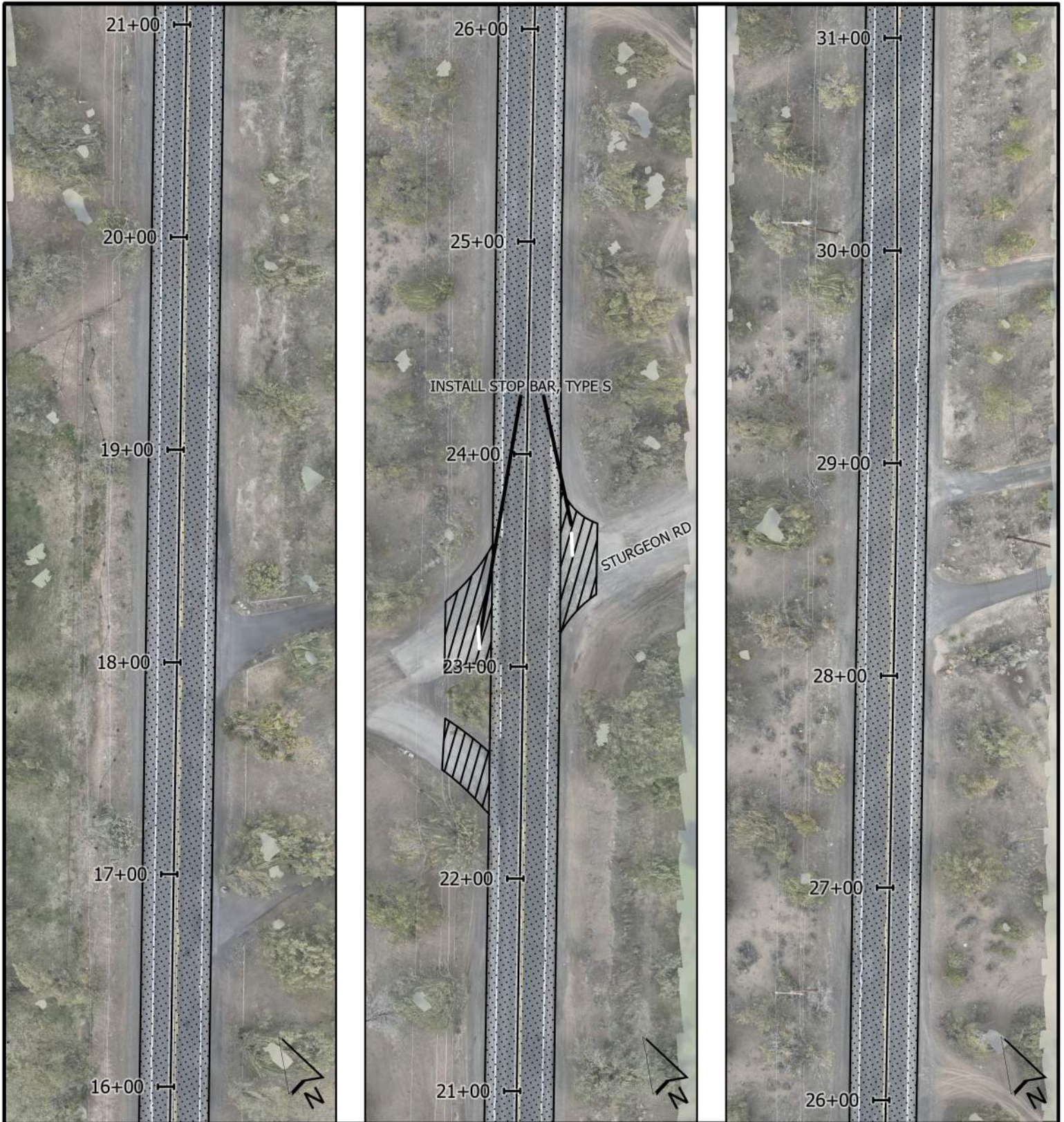

INSTALL STOP BAR, TYPE S

STURGEON RD

LEGEND

 3" INLAY, FULL-WIDTH
(SEE TYPICAL SECTION, SHEET 2)

 ASPHALT APPROACH
(SEE DETAIL, SHEET 3)

NOTES:

PERFORM ACP REPAIR AS DIRECTED PRIOR TO CONSTRUCTING INLAY.

INSTALL THERMOPLASTIC CENTERLINE STRIPING WITH TYPE IAR RECESSED PAVEMENT MARKERS ACCORDING TO EXISTING LAYOUT.

INSTALL THERMOPLASTIC EDGE LINE STRIPING, TYPE W-2.

INSTALL STOP BAR, TYPE S AND STOP/ STOP AHEAD LEGENDS AS SHOWN.

INSTALL TYPE 1 DELINEATORS AT FIELD-MARKED LOCATIONS.



ROAD DEPARTMENT

PLAN:
STA 16+00 to 31+00

SHEET NO:
6 of 26

DATE:
3/27/24

SCALE:
N.T.S.

DRAFTER: R. PINKSTON
REVIEWED BY: C. SMITH

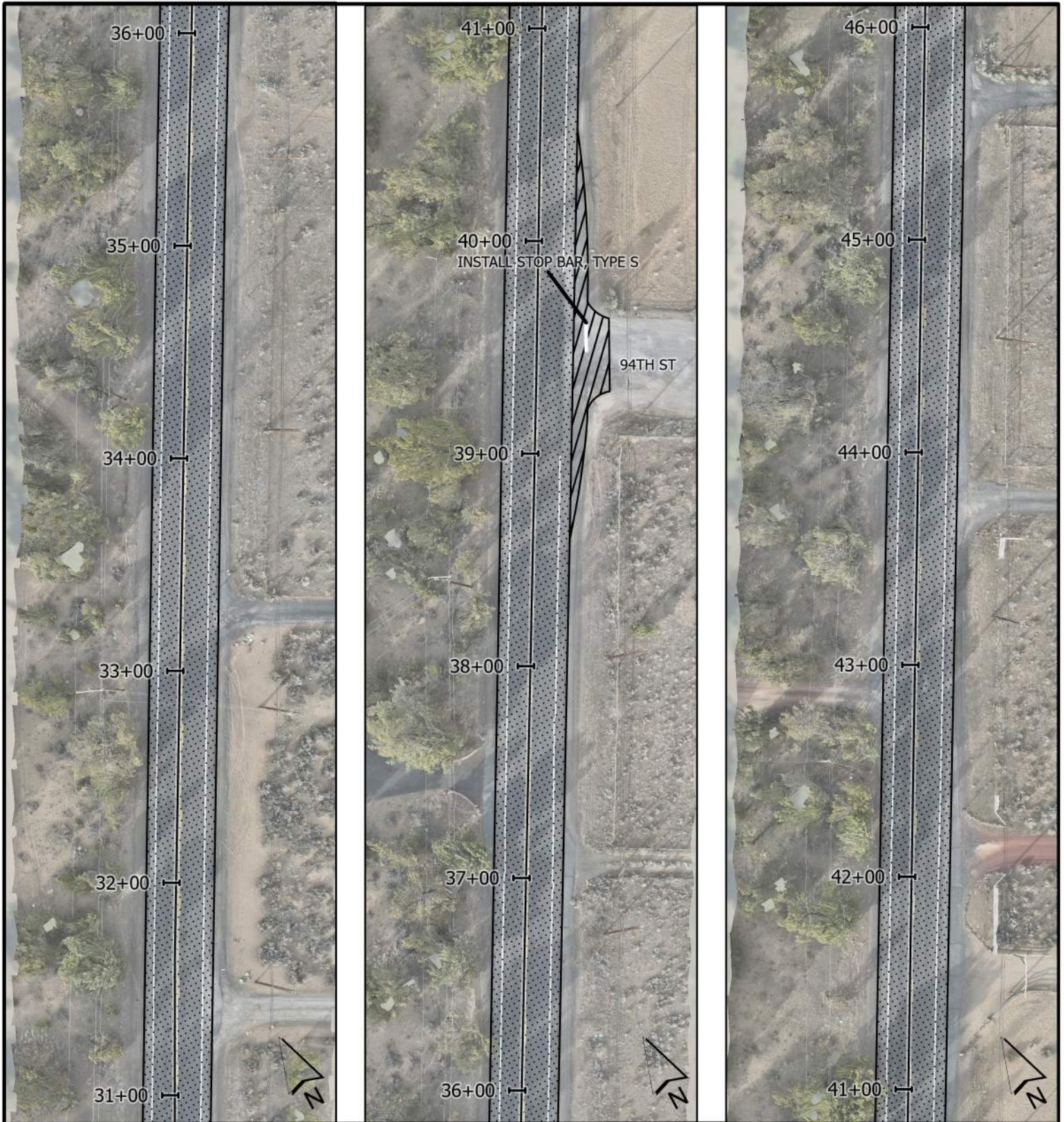

LEGEND

-  3" INLAY, FULL-WIDTH
(SEE TYPICAL SECTION, SHEET 2)
-  ASPHALT APPROACH
(SEE DETAIL, SHEET 3)

NOTES:

- PERFORM ACP REPAIR AS DIRECTED PRIOR TO CONSTRUCTING INLAY.
- INSTALL THERMOPLASTIC CENTERLINE STRIPING WITH TYPE IAR RECESSED PAVEMENT MARKERS ACCORDING TO EXISTING LAYOUT.
- INSTALL THERMOPLASTIC EDGE LINE STRIPING, TYPE W-2.
- INSTALL STOP BAR, TYPE S AND STOP/STOP AHEAD LEGENDS AS SHOWN.
- INSTALL TYPE 1 DELINEATORS AT FIELD-MARKED LOCATIONS.



ROAD DEPARTMENT

PLAN:
STA 31+00 to 46+00

SHEET NO:
7 of 26

DATE:
3/27/24

SCALE:
N.T.S.

DRAFTER: R. PINKSTON
REVIEWED BY: C. SMITH

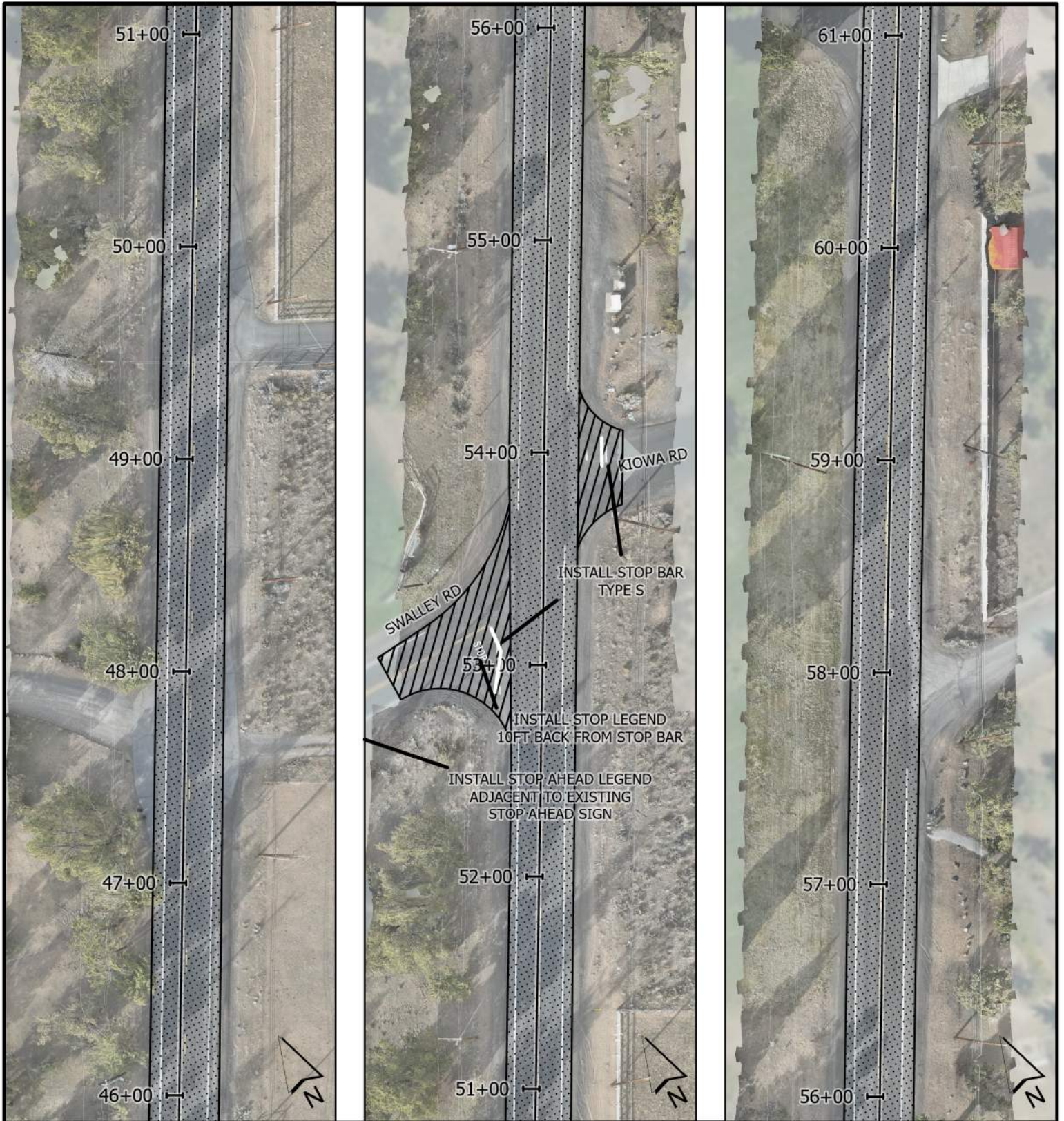

NOTES:

PERFORM ACP REPAIR AS DIRECTED PRIOR TO CONSTRUCTING INLAY.

INSTALL THERMOPLASTIC CENTERLINE STRIPING WITH TYPE IAR RECESSED PAVEMENT MARKERS ACCORDING TO EXISTING LAYOUT.

INSTALL THERMOPLASTIC EDGE LINE STRIPING, TYPE W-2.

INSTALL STOP BAR, TYPE S AND STOP/ STOP AHEAD LEGENDS AS SHOWN.

INSTALL TYPE 1 DELINEATORS AT FIELD-MARKED LOCATIONS.

LEGEND

 3" INLAY, FULL-WIDTH
(SEE TYPICAL SECTION, SHEET 2)

 ASPHALT APPROACH
(SEE DETAIL, SHEET 3)



ROAD DEPARTMENT

PLAN:
STA 46+00 to 61+00

SHEET NO:
8 of 26

DATE:
3/27/24

SCALE:
N.T.S.

DRAFTER: R. PINKSTON
REVIEWED BY: C. SMITH

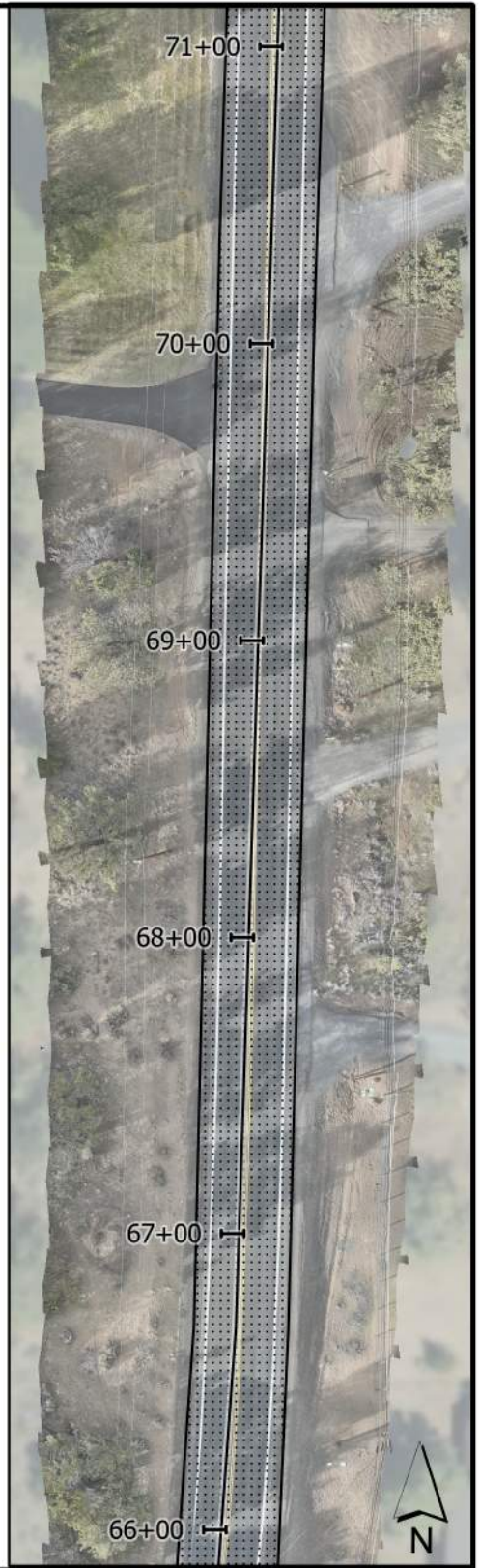

LEGEND

 3" INLAY, FULL-WIDTH
(SEE TYPICAL SECTION, SHEET 2)

NOTES:

PERFORM ACP REPAIR AS DIRECTED PRIOR TO CONSTRUCTING INLAY.

INSTALL THERMOPLASTIC CENTERLINE STRIPING WITH TYPE IAR RECESSED PAVEMENT MARKERS ACCORDING TO EXISTING LAYOUT.

INSTALL THERMOPLASTIC EDGE LINE STRIPING, TYPE W-2.

INSTALL STOP BAR, TYPE S AND STOP/ STOP AHEAD LEGENDS AS SHOWN.

INSTALL TYPE 1 DELINEATORS AT FIELD-MARKED LOCATIONS.



ROAD DEPARTMENT

PLAN:
STA 61+00 to 71+00

SHEET NO:
9 of 26

DATE:
3/27/24

SCALE:
N.T.S.

DRAFTER: R. PINKSTON
REVIEWED BY: C. SMITH



LEGEND

-  3" INLAY, FULL-WIDTH
(SEE TYPICAL SECTION, SHEET 2)
-  ASPHALT APPROACH
(SEE DETAIL, SHEET 3)

NOTES:

- PERFORM ACP REPAIR AS DIRECTED PRIOR TO CONSTRUCTING INLAY.
- INSTALL THERMOPLASTIC CENTERLINE STRIPING WITH TYPE IAR RECESSED PAVEMENT MARKERS ACCORDING TO EXISTING LAYOUT.
- INSTALL THERMOPLASTIC EDGE LINE STRIPING, TYPE W-2.
- INSTALL STOP BAR, TYPE S AND STOP/STOP AHEAD LEGENDS AS SHOWN.
- INSTALL TYPE 1 DELINEATORS AT FIELD-MARKED LOCATIONS.



ROAD DEPARTMENT

PLAN:
STA 71+00 to 86+00

SHEET NO:
10 of 26

DATE:
3/27/24

SCALE:
N.T.S.

DRAFTER: R. PINKSTON
REVIEWED BY: C. SMITH

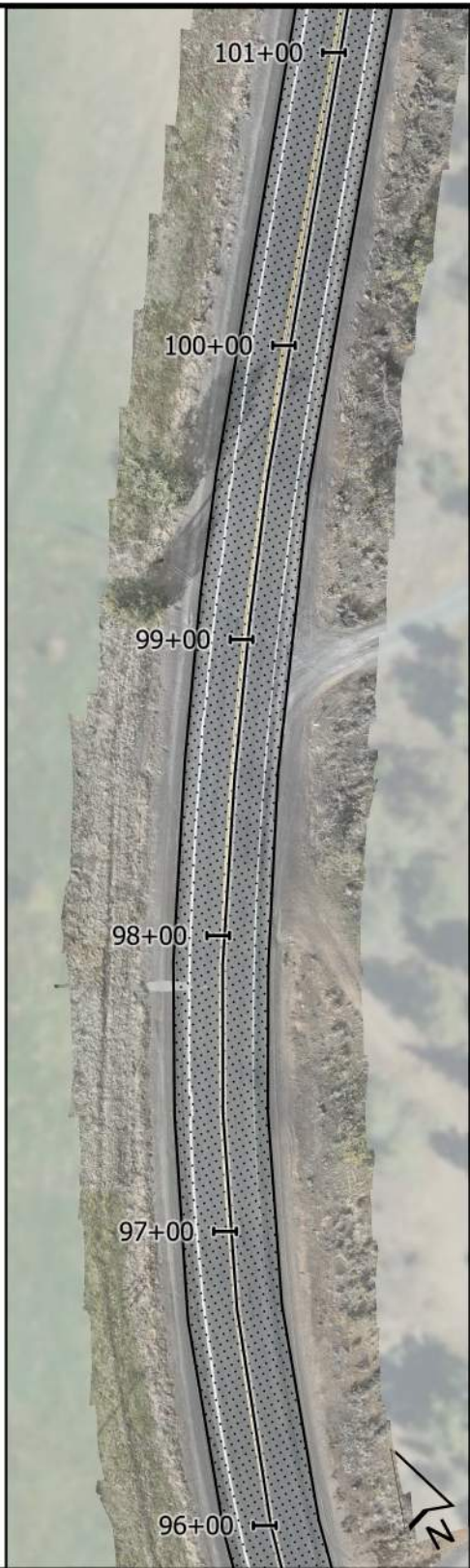
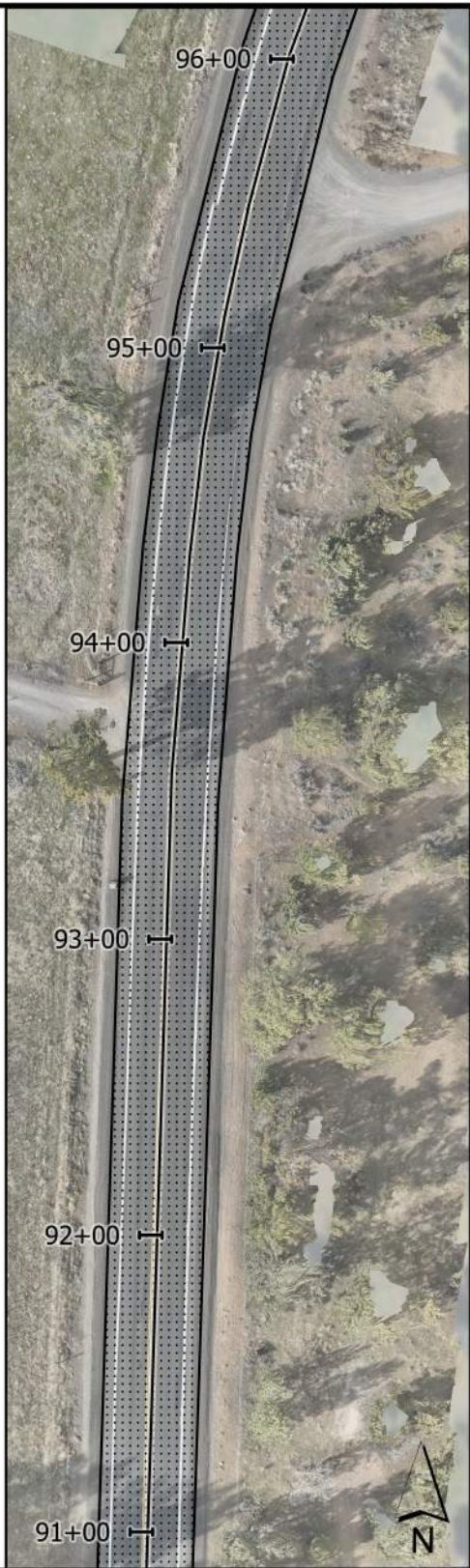
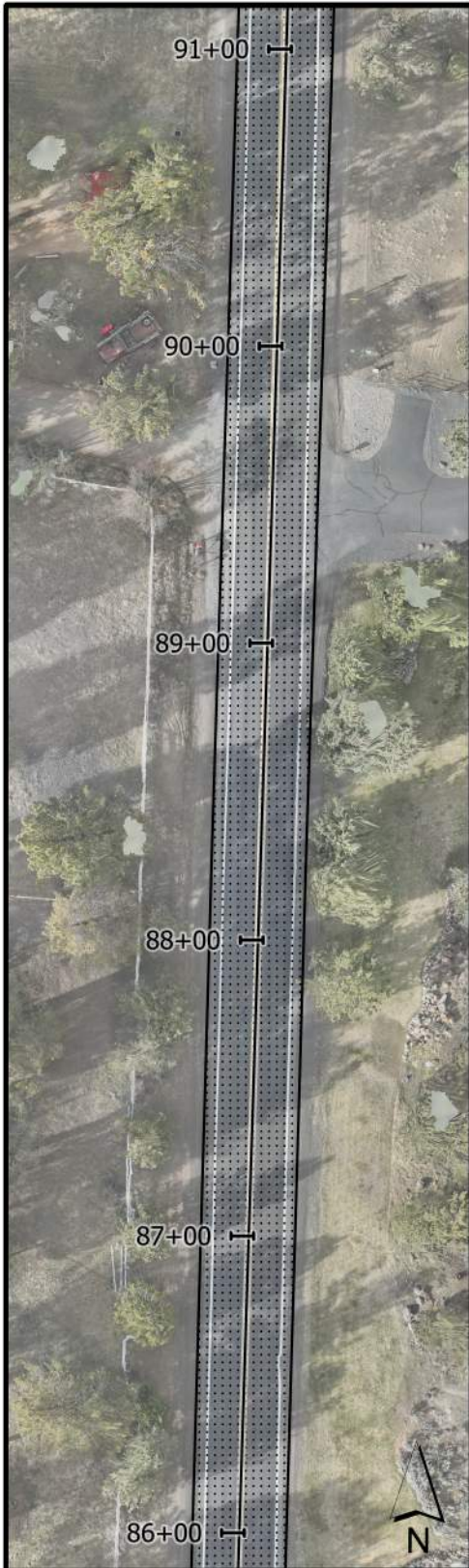

LEGEND



3" INLAY, FULL-WIDTH
(SEE TYPICAL SECTION, SHEET 2)

NOTES:

PERFORM ACP REPAIR AS DIRECTED PRIOR TO CONSTRUCTING INLAY.

INSTALL THERMOPLASTIC CENTERLINE STRIPING WITH TYPE IAR RECESSED PAVEMENT MARKERS ACCORDING TO EXISTING LAYOUT.

INSTALL THERMOPLASTIC EDGE LINE STRIPING, TYPE W-2.

INSTALL STOP BAR, TYPE S AND STOP/STOP AHEAD LEGENDS AS SHOWN.

INSTALL TYPE 1 DELINEATORS AT FIELD-MARKED LOCATIONS.



ROAD DEPARTMENT

PLAN:
STA 86+00 to 101+00

SHEET NO:
11 of 26

DATE:
3/27/24

SCALE:
N.T.S.

DRAFTER: R. PINKSTON
REVIEWED BY: C. SMITH

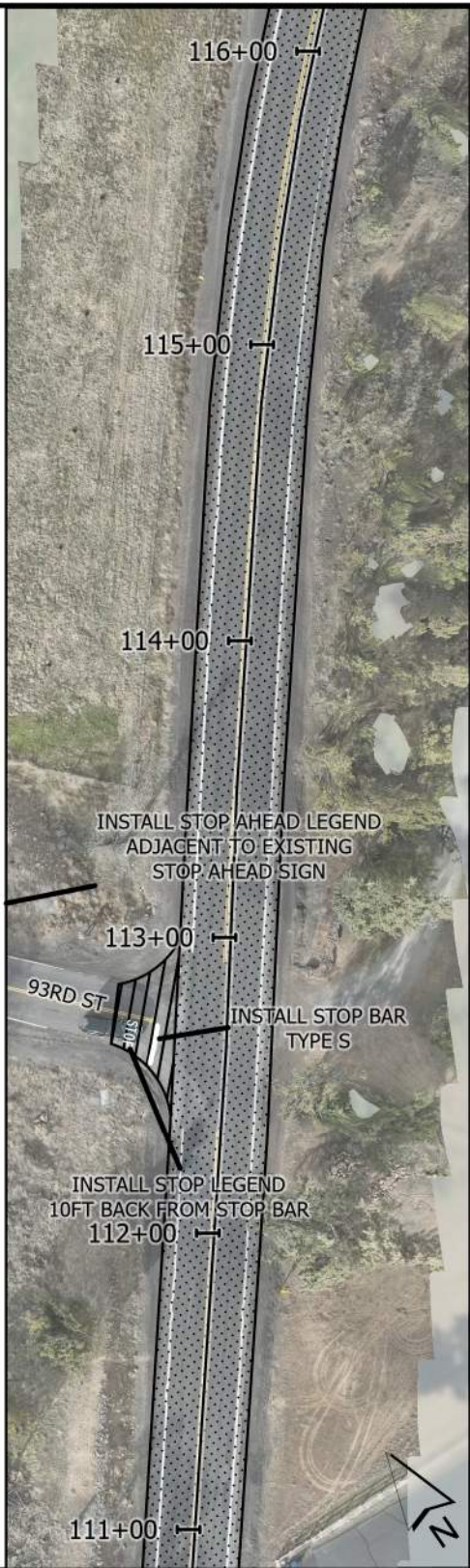
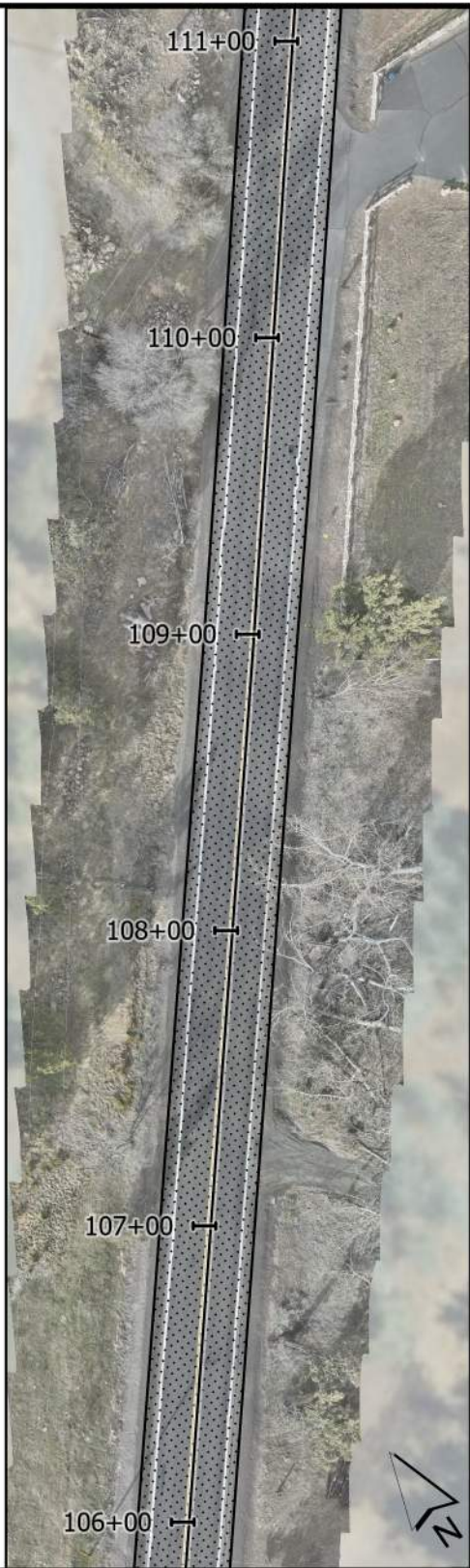
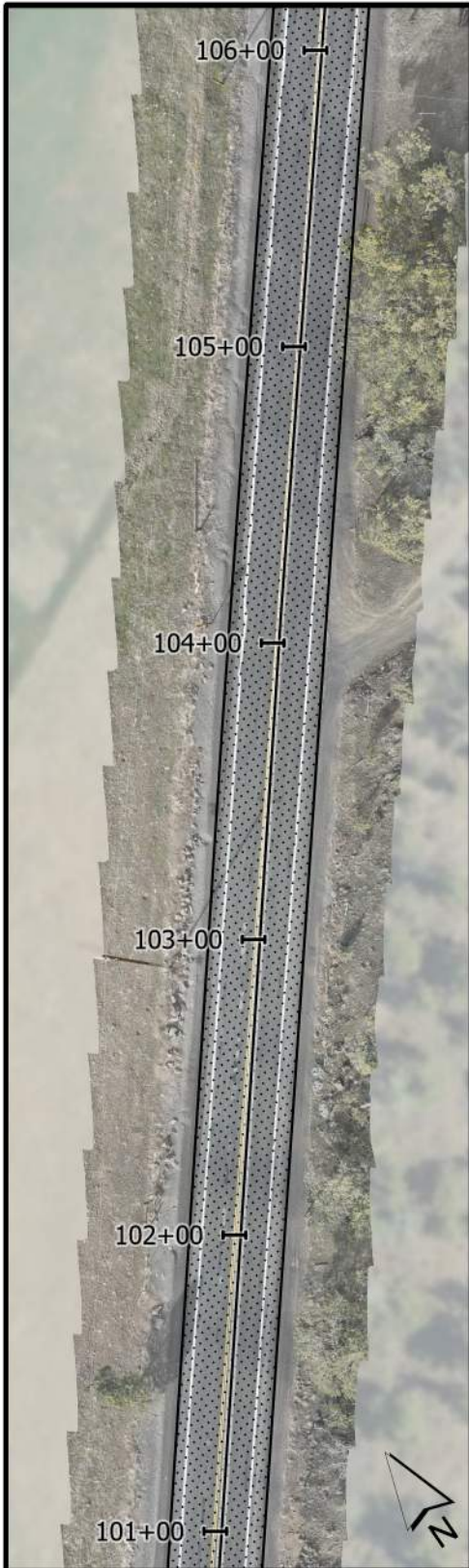

LEGEND

-  3" INLAY, FULL-WIDTH
(SEE TYPICAL SECTION, SHEET 2)
-  ASPHALT APPROACH
(SEE DETAIL, SHEET 3)

NOTES:

- PERFORM ACP REPAIR AS DIRECTED PRIOR TO CONSTRUCTING INLAY.
- INSTALL THERMOPLASTIC CENTERLINE STRIPING WITH TYPE IAR RECESSED PAVEMENT MARKERS ACCORDING TO EXISTING LAYOUT.
- INSTALL THERMOPLASTIC EDGE LINE STRIPING, TYPE W-2.
- INSTALL STOP BAR, TYPE S AND STOP/ STOP AHEAD LEGENDS AS SHOWN.
- INSTALL TYPE 1 DELINEATORS AT FIELD-MARKED LOCATIONS.



ROAD DEPARTMENT

PLAN: STA 101+00 to 116+00

SHEET NO: 12 of 26

DATE: 3/27/24

SCALE: N.T.S.

DRAFTER: R. PINKSTON
REVIEWED BY: C. SMITH

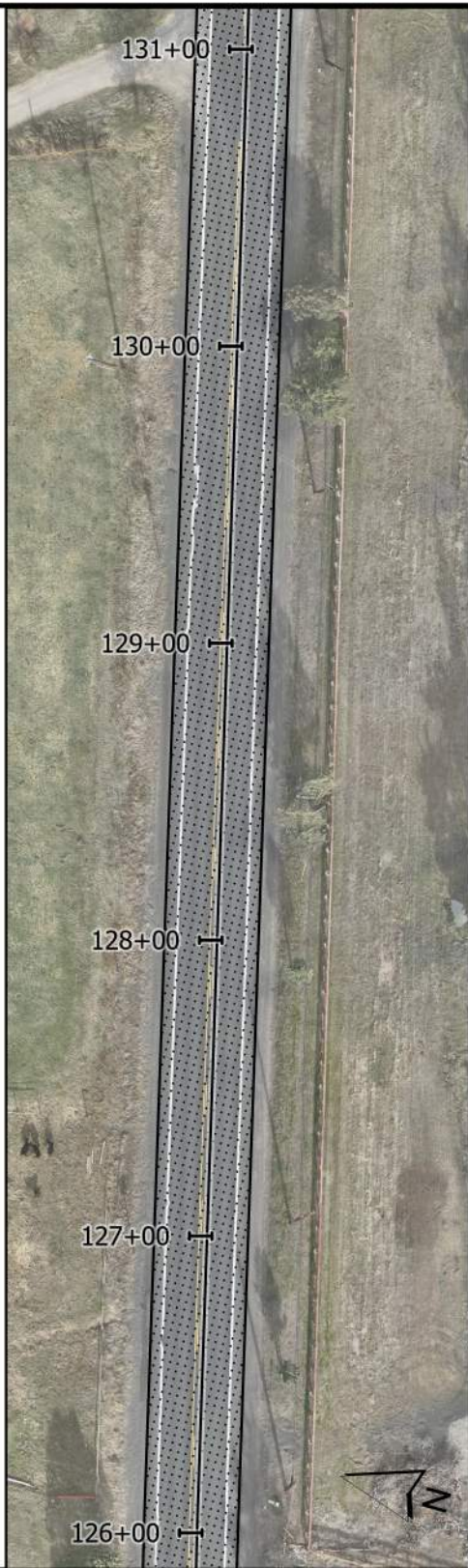
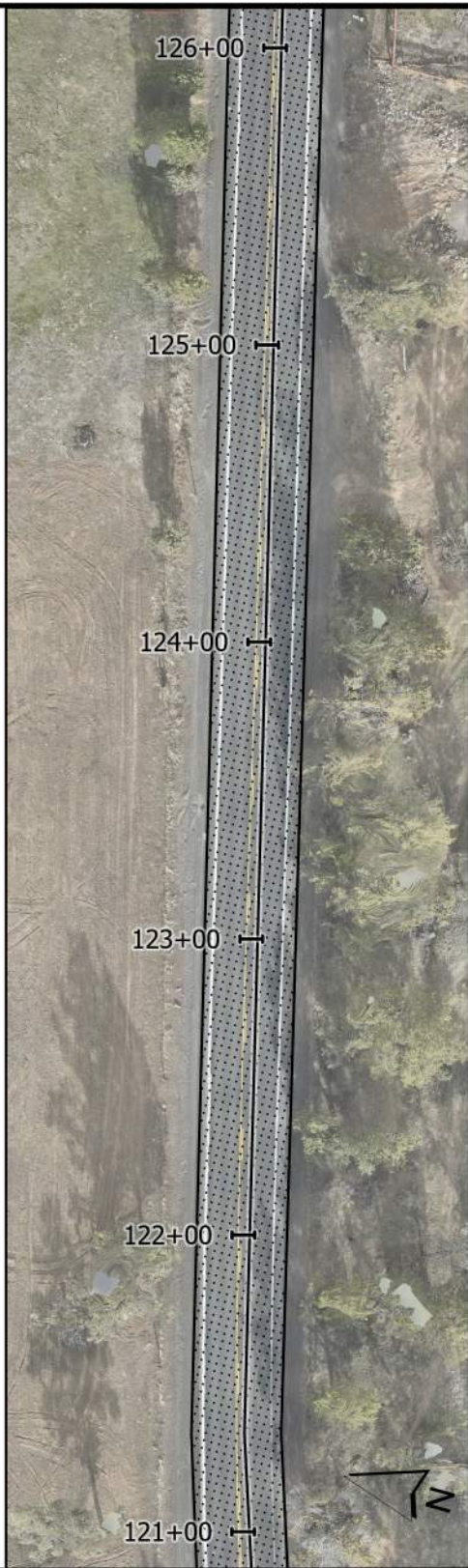
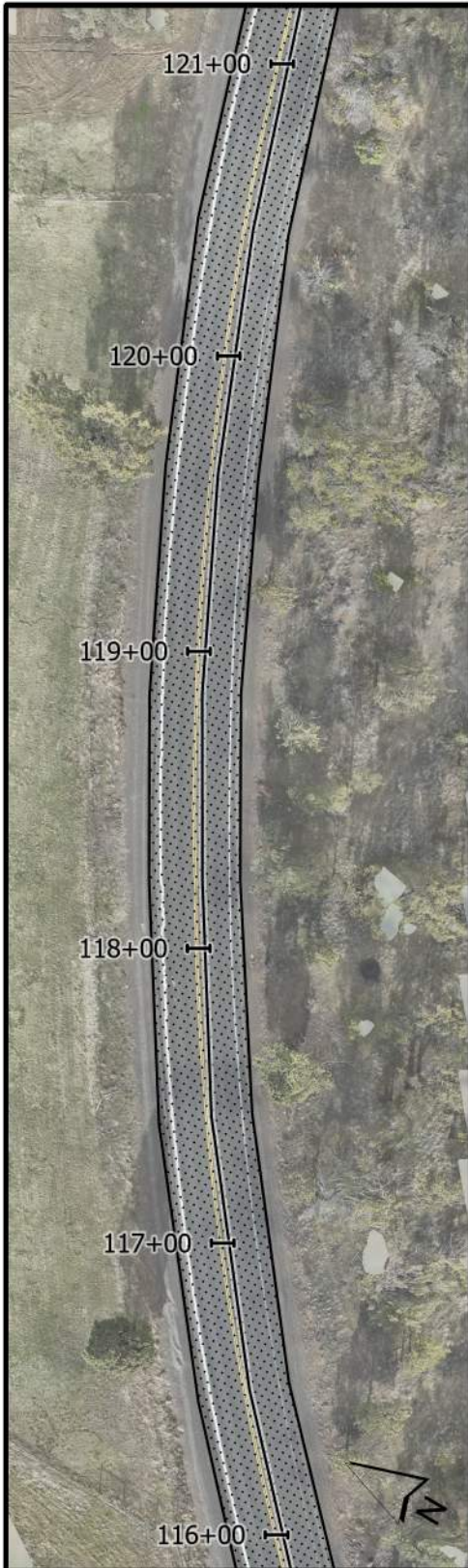

LEGEND

 3" INLAY, FULL-WIDTH
(SEE TYPICAL SECTION, SHEET 2)

NOTES:

PERFORM ACP REPAIR AS DIRECTED PRIOR TO CONSTRUCTING INLAY.

INSTALL THERMOPLASTIC CENTERLINE STRIPING WITH TYPE IAR RECESSED PAVEMENT MARKERS ACCORDING TO EXISTING LAYOUT.

INSTALL THERMOPLASTIC EDGE LINE STRIPING, TYPE W-2.

INSTALL STOP BAR, TYPE S AND STOP/STOP AHEAD LEGENDS AS SHOWN.

INSTALL TYPE 1 DELINEATORS AT FIELD-MARKED LOCATIONS.



ROAD DEPARTMENT

PLAN:
STA 116+00 to 131+00

SHEET NO:
13 of 26

DATE:
3/27/24

SCALE:
N.T.S.

DRAFTER: R. PINKSTON
REVIEWED BY: C. SMITH

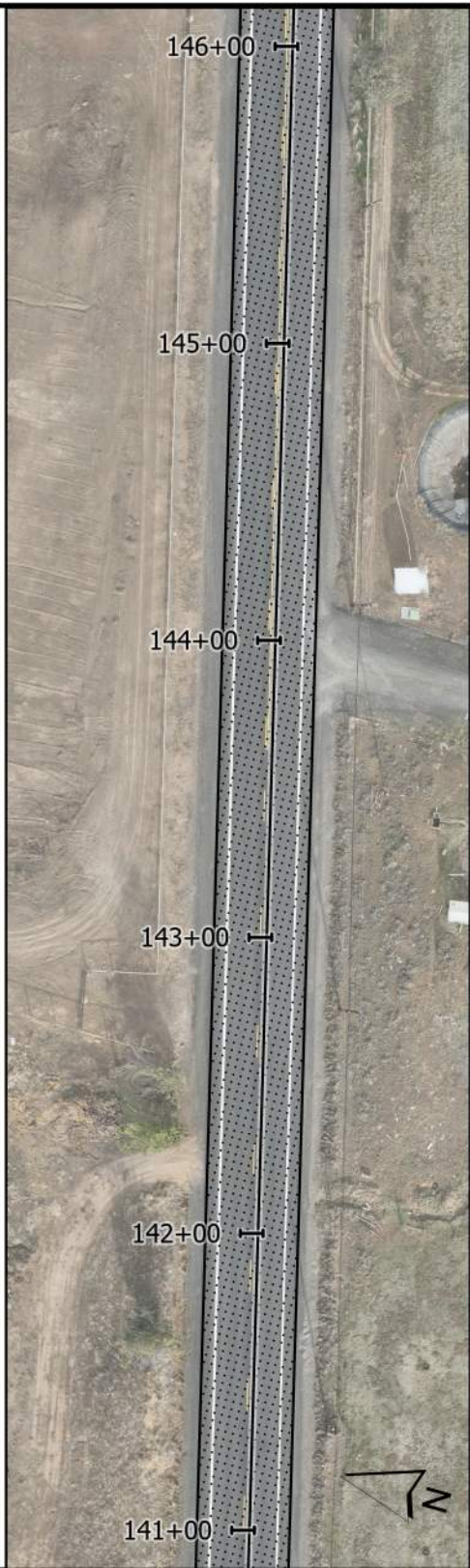
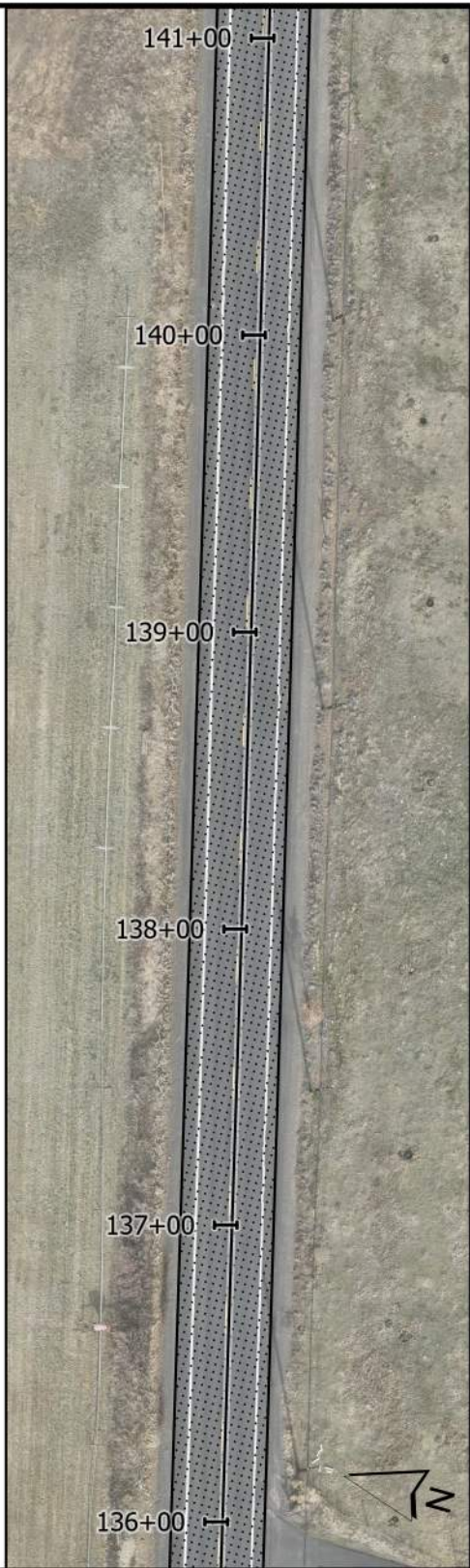
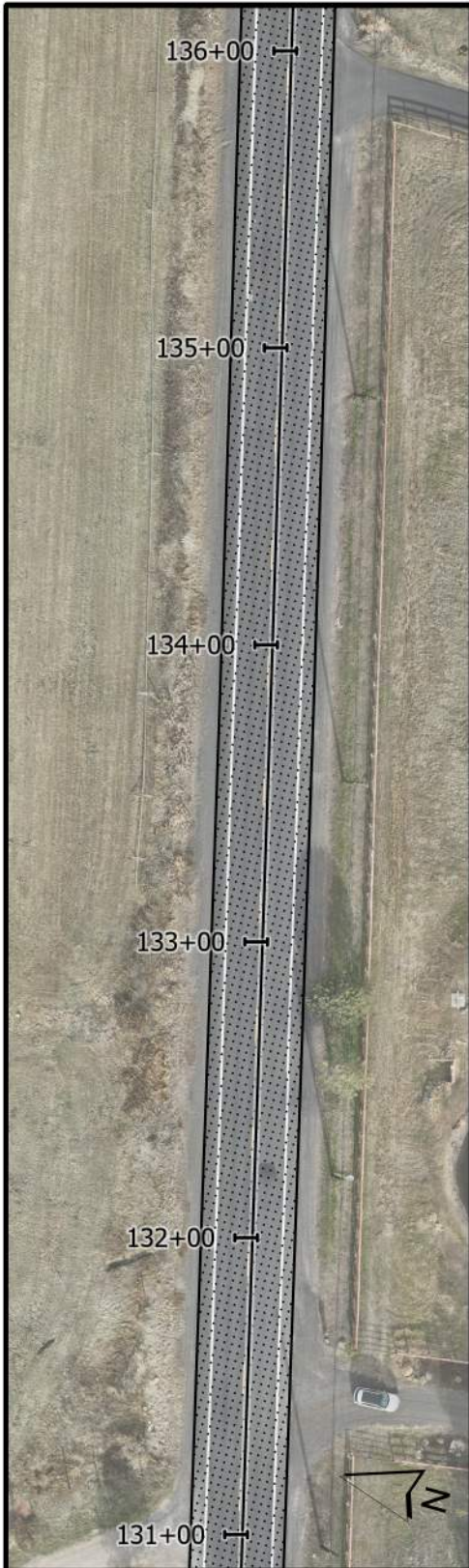

LEGEND

 3" INLAY, FULL-WIDTH
(SEE TYPICAL SECTION, SHEET 2)

NOTES:

- PERFORM ACP REPAIR AS DIRECTED PRIOR TO CONSTRUCTING INLAY.
- INSTALL THERMOPLASTIC CENTERLINE STRIPING WITH TYPE IAR RECESSED PAVEMENT MARKERS ACCORDING TO EXISTING LAYOUT.
- INSTALL THERMOPLASTIC EDGE LINE STRIPING, TYPE W-2.
- INSTALL STOP BAR, TYPE S AND STOP/STOP AHEAD LEGENDS AS SHOWN.
- INSTALL TYPE 1 DELINEATORS AT FIELD-MARKED LOCATIONS.



ROAD DEPARTMENT

PLAN:
STA 131+00 to 146+00

SHEET NO:
14 of 26

DATE:
3/27/24

SCALE:
N.T.S.

DRAFTER: R. PINKSTON
REVIEWED BY: C. SMITH



LEGEND

 3" INLAY, FULL-WIDTH
(SEE TYPICAL SECTION, SHEET 2)

NOTES:

PERFORM ACP REPAIR AS DIRECTED PRIOR TO CONSTRUCTING INLAY.

INSTALL THERMOPLASTIC CENTERLINE STRIPING WITH TYPE IAR RECESSED PAVEMENT MARKERS ACCORDING TO EXISTING LAYOUT.

INSTALL THERMOPLASTIC EDGE LINE STRIPING, TYPE W-2.

INSTALL STOP BAR, TYPE S AND STOP/ STOP AHEAD LEGENDS AS SHOWN.

INSTALL TYPE 1 DELINEATORS AT FIELD-MARKED LOCATIONS.



ROAD DEPARTMENT

PLAN:
STA 146+00 to 161+00

SHEET NO:
15 of 26

DATE:
3/27/24

SCALE:
N.T.S.

DRAFTER: R. PINKSTON
REVIEWED BY: C. SMITH

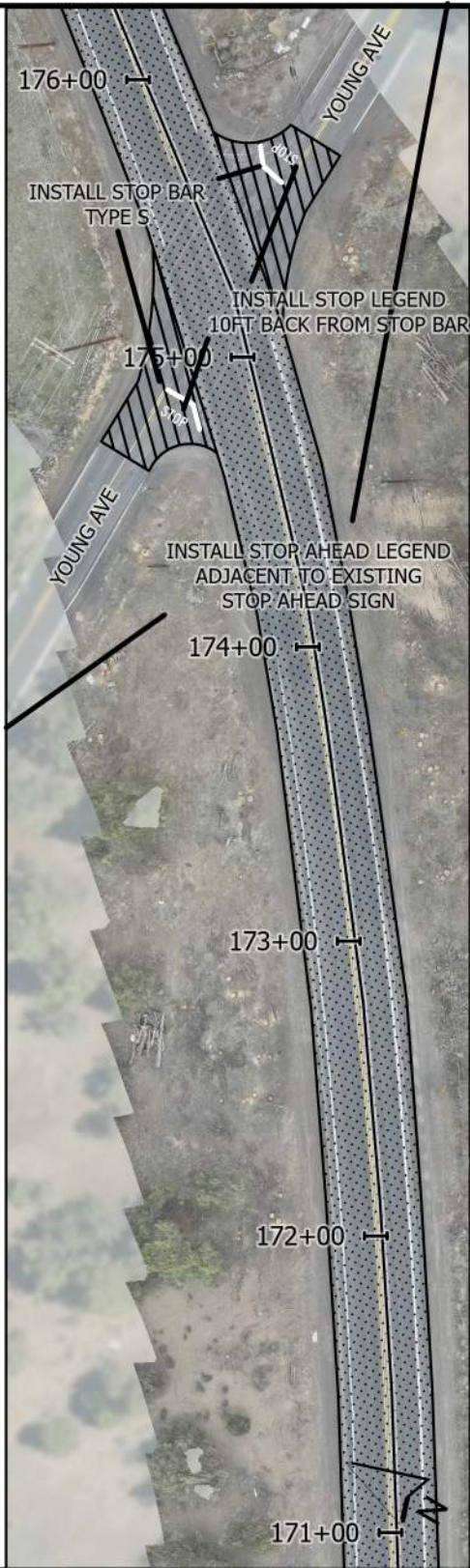
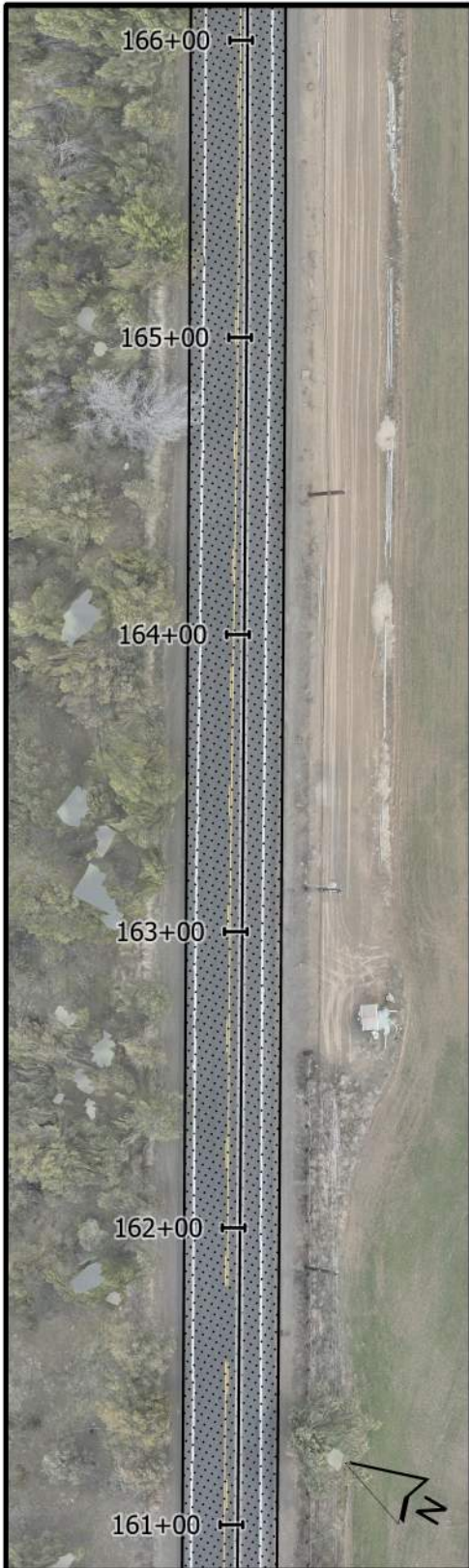

LEGEND

-  3" INLAY, FULL-WIDTH
(SEE TYPICAL SECTION, SHEET 2)
-  ASPHALT APPROACH
(SEE DETAIL, SHEET 3)

NOTES:

- PERFORM ACP REPAIR AS DIRECTED PRIOR TO CONSTRUCTING INLAY.
- INSTALL THERMOPLASTIC CENTERLINE STRIPING WITH TYPE IAR RECESSED PAVEMENT MARKERS ACCORDING TO EXISTING LAYOUT.
- INSTALL THERMOPLASTIC EDGE LINE STRIPING, TYPE W-2.
- INSTALL STOP BAR, TYPE S AND STOP/STOP AHEAD LEGENDS AS SHOWN.
- INSTALL TYPE 1 DELINEATORS AT FIELD-MARKED LOCATIONS.



ROAD DEPARTMENT

PLAN:
STA 161+00 to 176+00

SHEET NO:
16 of 26

DATE:
3/27/24

SCALE:
N.T.S.

DRAFTER: R. PINKSTON
REVIEWED BY: C. SMITH



LEGEND

 3" INLAY, FULL-WIDTH
(SEE TYPICAL SECTION, SHEET 2)

NOTES:

PERFORM ACP REPAIR AS DIRECTED PRIOR TO CONSTRUCTING INLAY.

INSTALL THERMOPLASTIC CENTERLINE STRIPING WITH TYPE IAR RECESSED PAVEMENT MARKERS ACCORDING TO EXISTING LAYOUT.

INSTALL THERMOPLASTIC EDGE LINE STRIPING, TYPE W-2.

INSTALL STOP BAR, TYPE S AND STOP/ STOP AHEAD LEGENDS AS SHOWN.

INSTALL TYPE 1 DELINEATORS AT FIELD-MARKED LOCATIONS.



ROAD DEPARTMENT

PLAN: STA 176+00 to 191+00

SHEET NO: 17 of 26

DATE: 3/27/24

SCALE: N.T.S.

DRAFTER: R. PINKSTON
REVIEWED BY: C. SMITH

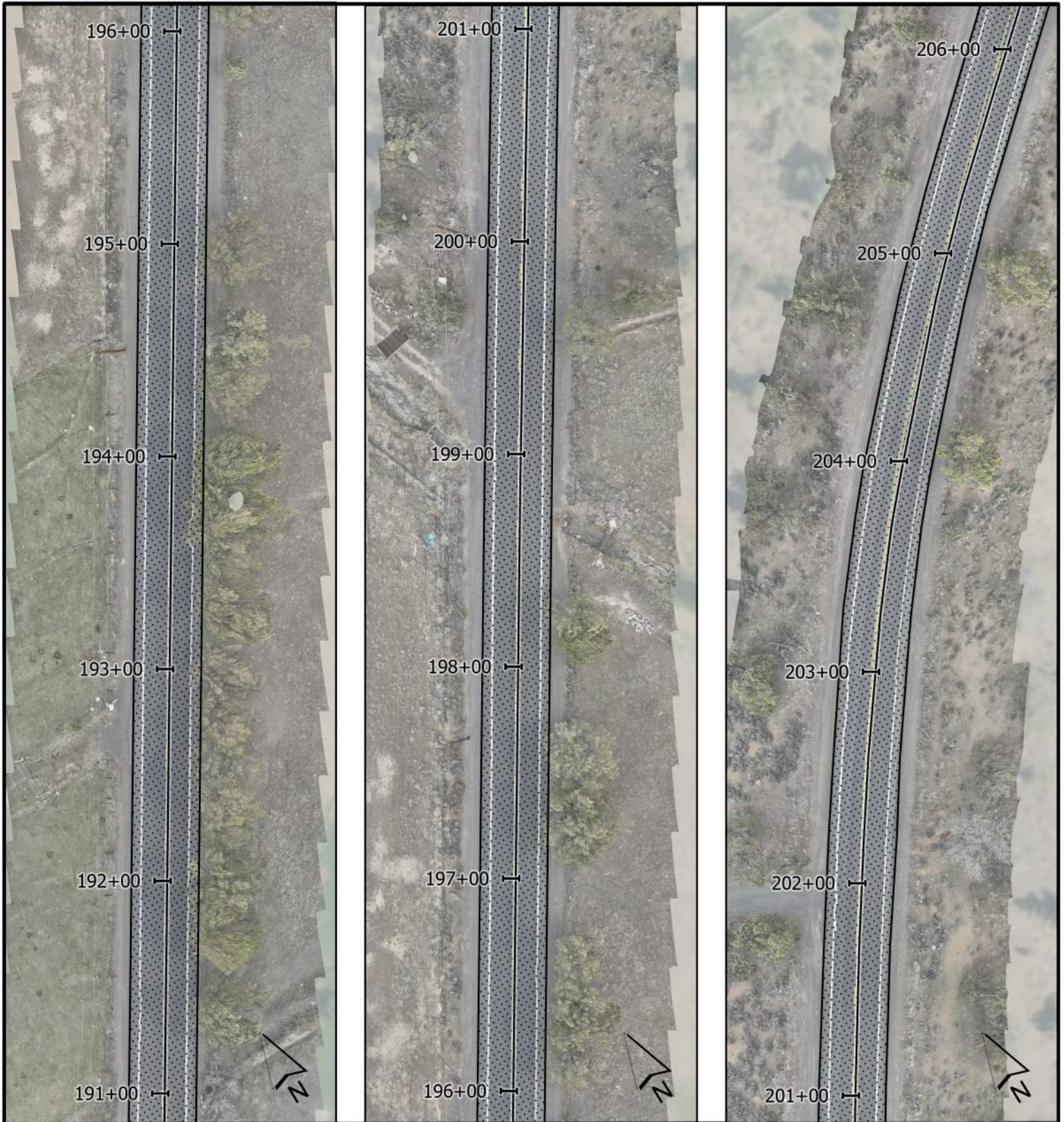

LEGEND

 3" INLAY, FULL-WIDTH
(SEE TYPICAL SECTION, SHEET 2)

NOTES:

PERFORM ACP REPAIR AS DIRECTED PRIOR TO CONSTRUCTING INLAY.

INSTALL THERMOPLASTIC CENTERLINE STRIPING WITH TYPE IAR RECESSED PAVEMENT MARKERS ACCORDING TO EXISTING LAYOUT.

INSTALL THERMOPLASTIC EDGE LINE STRIPING, TYPE W-2.

INSTALL STOP BAR, TYPE S AND STOP/ STOP AHEAD LEGENDS AS SHOWN.

INSTALL TYPE 1 DELINEATORS AT FIELD-MARKED LOCATIONS.



ROAD DEPARTMENT

PLAN:
STA 191+00 to 206+00

SHEET NO:
18 of 26

DATE:
3/27/24

SCALE:
N.T.S.

DRAFTER: R. PINKSTON
REVIEWED BY: C. SMITH



LEGEND

 3" INLAY, FULL-WIDTH
(SEE TYPICAL SECTION, SHEET 2)

NOTES:

PERFORM ACP REPAIR AS DIRECTED PRIOR TO CONSTRUCTING INLAY.

INSTALL THERMOPLASTIC CENTERLINE STRIPING WITH TYPE IAR RECESSED PAVEMENT MARKERS ACCORDING TO EXISTING LAYOUT.

INSTALL THERMOPLASTIC EDGE LINE STRIPING, TYPE W-2.

INSTALL STOP BAR, TYPE S AND STOP/ STOP AHEAD LEGENDS AS SHOWN.

INSTALL TYPE 1 DELINEATORS AT FIELD-MARKED LOCATIONS.



ROAD DEPARTMENT

PLAN:
STA 206+00 to 221+00

SHEET NO:
19 of 26

DATE:
3/27/24

SCALE:
N.T.S.

DRAFTER: R. PINKSTON
REVIEWED BY: C. SMITH



REPLACE EXISTING STRIPING WITH TYPE D R-40

LEGEND

 3" INLAY, FULL-WIDTH
(SEE TYPICAL SECTION, SHEET 2)

 STRIPE REMOVAL

NOTES:

INSTALL TYPE IAR RECESSED PAVEMENT MARKERS ALONG EXISTING ND STRIPING. SEE TYPE ND R-40 ON TM502.

REMOVE EXISTING ND STRIPING AS SHOWN. REPLACE WITH TYPE D R-40.

NOTES (CONT.):

PERFORM ACP REPAIR AS DIRECTED PRIOR TO CONSTRUCTING INLAY.

INSTALL THERMOPLASTIC CENTERLINE STRIPING WITH TYPE IAR RECESSED PAVEMENT MARKERS ACCORDING TO EXISTING LAYOUT.

INSTALL THERMOPLASTIC EDGE LINE STRIPING, TYPE W-2.

INSTALL STOP BAR, TYPE S AND STOP/ STOP AHEAD LEGENDS AS SHOWN.

INSTALL TYPE 1 DELINEATORS AT FIELD-MARKED LOCATIONS.



ROAD DEPARTMENT

PLAN: STA 221+00 to 236+00

SHEET NO: 20 of 26

DATE: 3/27/24

SCALE: N.T.S.

DRAFTER: R. PINKSTON
REVIEWED BY: C. SMITH

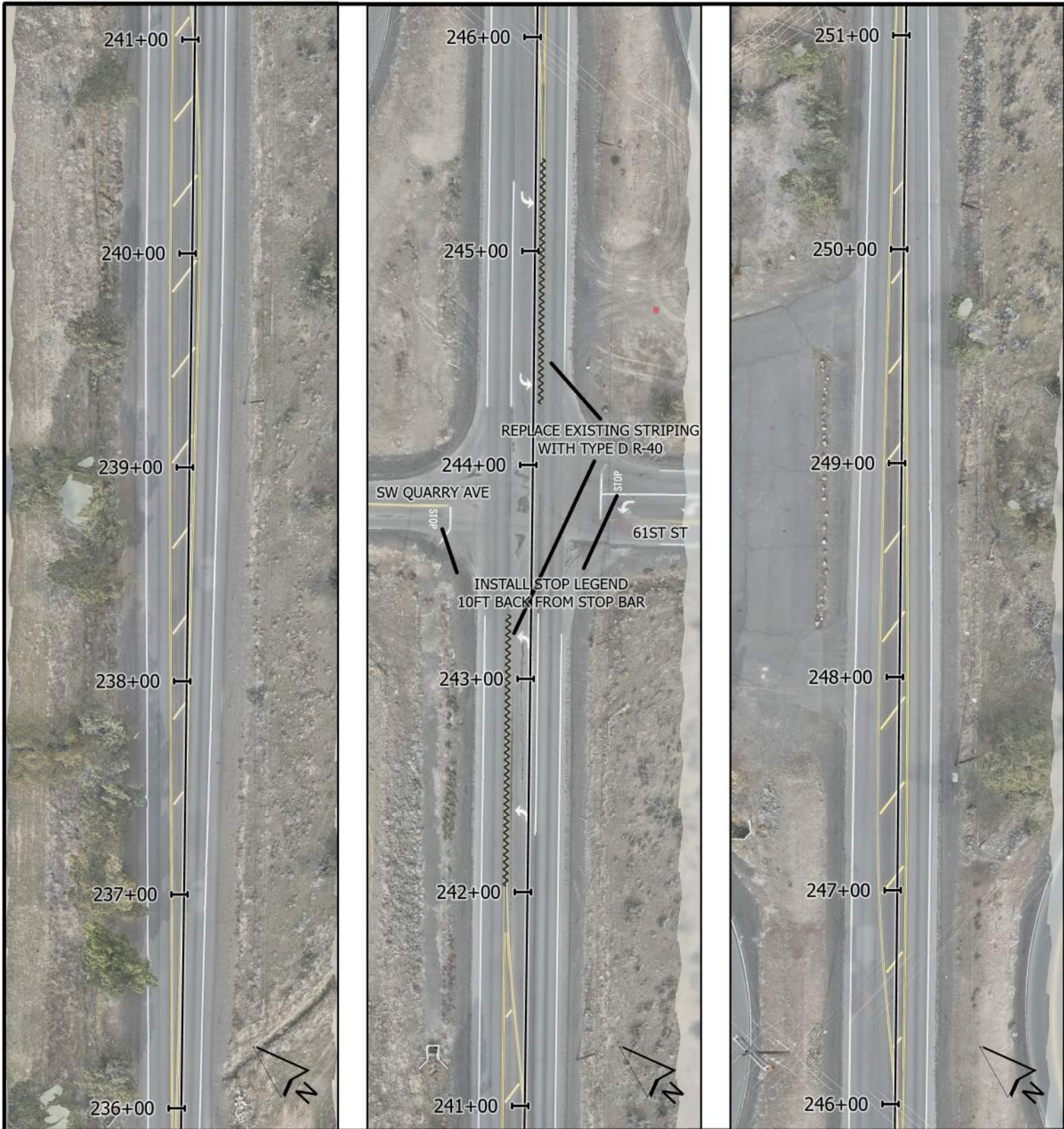

LEGEND

 3" INLAY, FULL-WIDTH
(SEE TYPICAL SECTION, SHEET 2)

 STRIPE REMOVAL

NOTES:

INSTALL TYPE IAR RECESSED PAVEMENT MARKERS ALONG EXISTING ND STRIPING. SEE TYPE ND R-40 ON TM502.

REMOVE EXISTING ND STRIPING AS SHOWN. REPLACE WITH TYPE D R-40.

NOTES (CONT.):

PERFORM ACP REPAIR AS DIRECTED PRIOR TO CONSTRUCTING INLAY.

INSTALL THERMOPLASTIC CENTERLINE STRIPING WITH TYPE IAR RECESSED PAVEMENT MARKERS ACCORDING TO EXISTING LAYOUT.

INSTALL THERMOPLASTIC EDGE LINE STRIPING, TYPE W-2.

INSTALL STOP BAR, TYPE S AND STOP/ STOP AHEAD LEGENDS AS SHOWN.

INSTALL TYPE 1 DELINEATORS AT FIELD-MARKED LOCATIONS.



ROAD DEPARTMENT

PLAN:
STA 236+00 to 251+00

SHEET NO:
21 of 26

DATE:
3/27/24

SCALE:
N.T.S.

DRAFTER: R. PINKSTON
REVIEWED BY: C. SMITH



REPLACE EXISTING STRIPING WITH TYPE D R-40

LEGEND

 3" INLAY, FULL-WIDTH
(SEE TYPICAL SECTION, SHEET 2)

 STRIPE REMOVAL

NOTES:

INSTALL TYPE IAR RECESSED PAVEMENT MARKERS ALONG EXISTING ND STRIPING. SEE TYPE ND R-40 ON TM502.

REMOVE EXISTING ND STRIPING AS SHOWN. REPLACE WITH TYPE D R-40.

NOTES (CONT.):

PERFORM ACP REPAIR AS DIRECTED PRIOR TO CONSTRUCTING INLAY.

INSTALL THERMOPLASTIC CENTERLINE STRIPING WITH TYPE IAR RECESSED PAVEMENT MARKERS ACCORDING TO EXISTING LAYOUT.

INSTALL THERMOPLASTIC EDGE LINE STRIPING, TYPE W-2.

INSTALL STOP BAR, TYPE S AND STOP/ STOP AHEAD LEGENDS AS SHOWN.

INSTALL TYPE 1 DELINEATORS AT FIELD-MARKED LOCATIONS.



ROAD DEPARTMENT

PLAN: STA 251+00 to 266+00

SHEET NO: 22 of 26

DATE: 3/27/24

SCALE: N.T.S.

DRAFTER: R. PINKSTON

REVIEWED BY: C. SMITH



LEGEND

 3" INLAY, FULL-WIDTH
(SEE TYPICAL SECTION, SHEET 2)

NOTES:

PERFORM ACP REPAIR AS DIRECTED PRIOR TO CONSTRUCTING INLAY.

INSTALL THERMOPLASTIC CENTERLINE STRIPING WITH TYPE IAR RECESSED PAVEMENT MARKERS ACCORDING TO EXISTING LAYOUT.

INSTALL THERMOPLASTIC EDGE LINE STRIPING, TYPE W-2.

INSTALL STOP BAR, TYPE S AND STOP/ STOP AHEAD LEGENDS AS SHOWN.

INSTALL TYPE 1 DELINEATORS AT FIELD-MARKED LOCATIONS.



ROAD DEPARTMENT

PLAN:
STA 266+00 to 281+00

SHEET NO:
23 of 26

DATE:
3/27/24

SCALE:
N.T.S.

DRAFTER: R. PINKSTON
REVIEWED BY: C. SMITH

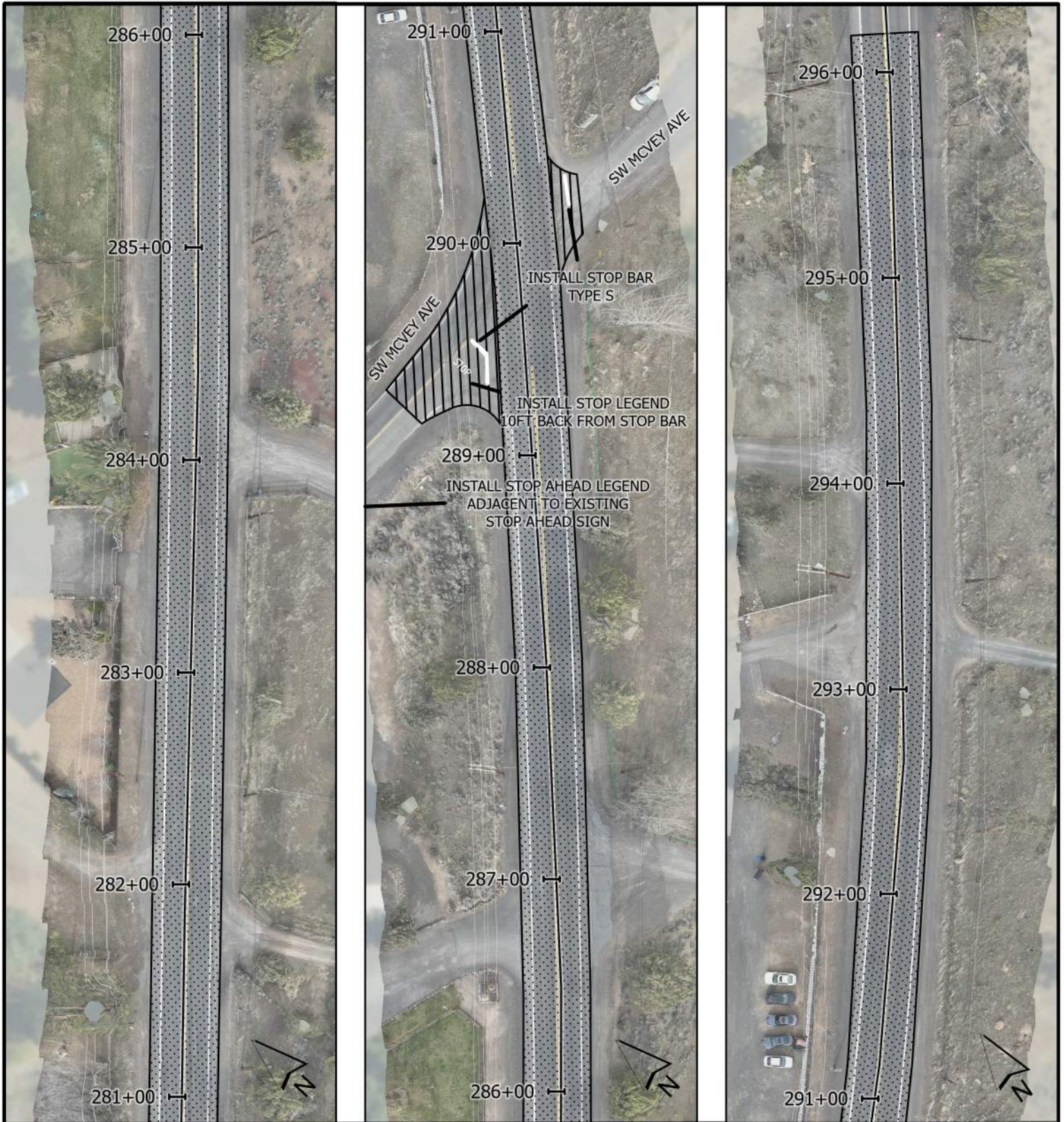

LEGEND

-  3" INLAY, FULL-WIDTH
(SEE TYPICAL SECTION, SHEET 2)
-  ASPHALT APPROACH
(SEE DETAIL, SHEET 3)

NOTES:

- PERFORM ACP REPAIR AS DIRECTED PRIOR TO CONSTRUCTING INLAY.
- INSTALL THERMOPLASTIC CENTERLINE STRIPING WITH TYPE IAR RECESSED PAVEMENT MARKERS ACCORDING TO EXISTING LAYOUT.
- INSTALL THERMOPLASTIC EDGE LINE STRIPING, TYPE W-2.
- INSTALL STOP BAR, TYPE S AND STOP/ STOP AHEAD LEGENDS AS SHOWN.
- INSTALL TYPE 1 DELINEATORS AT FIELD-MARKED LOCATIONS.



ROAD DEPARTMENT

PLAN:
STA 281+00 to END

SHEET NO:
24 of 26

DATE:
3/27/24

SCALE:
N.T.S.

DRAFTER: R. PINKSTON
REVIEWED BY: C. SMITH

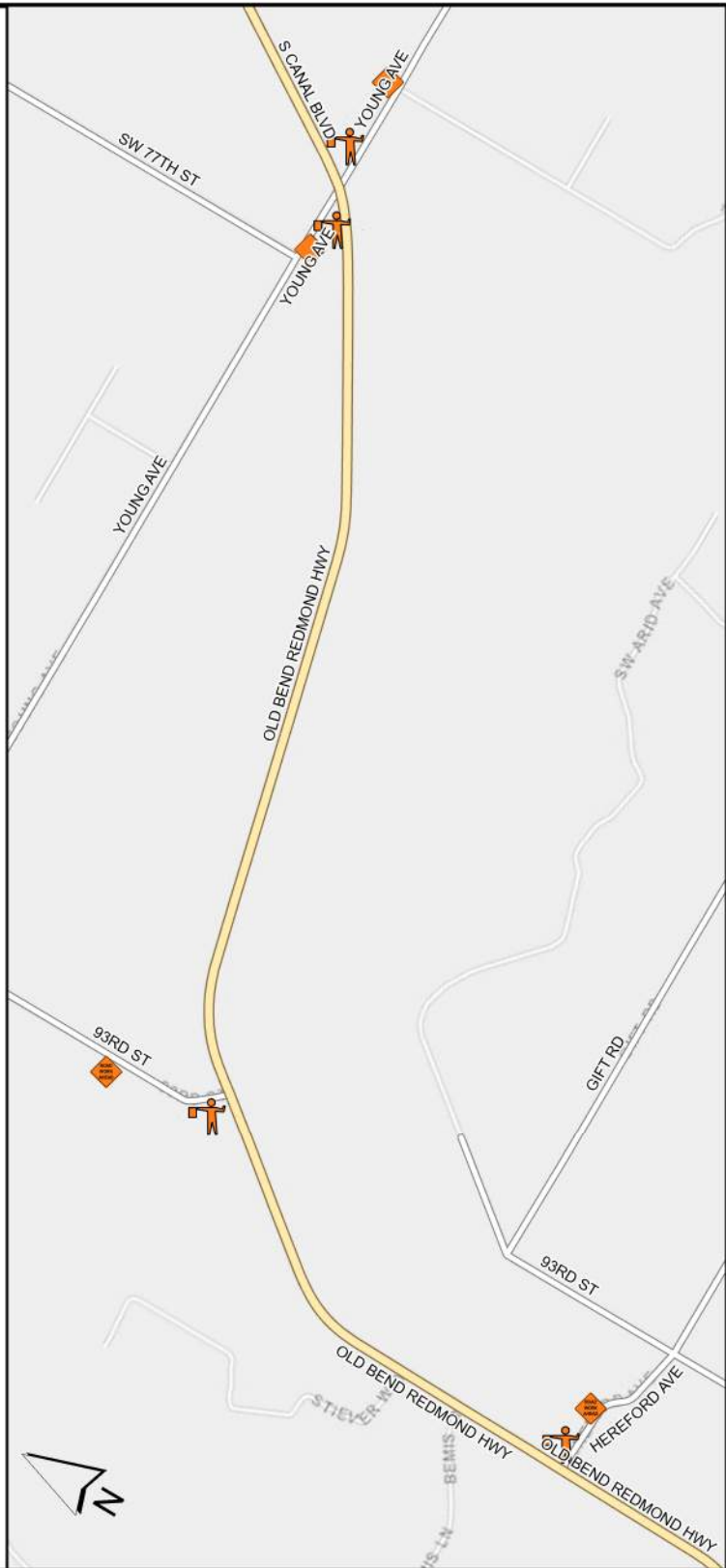
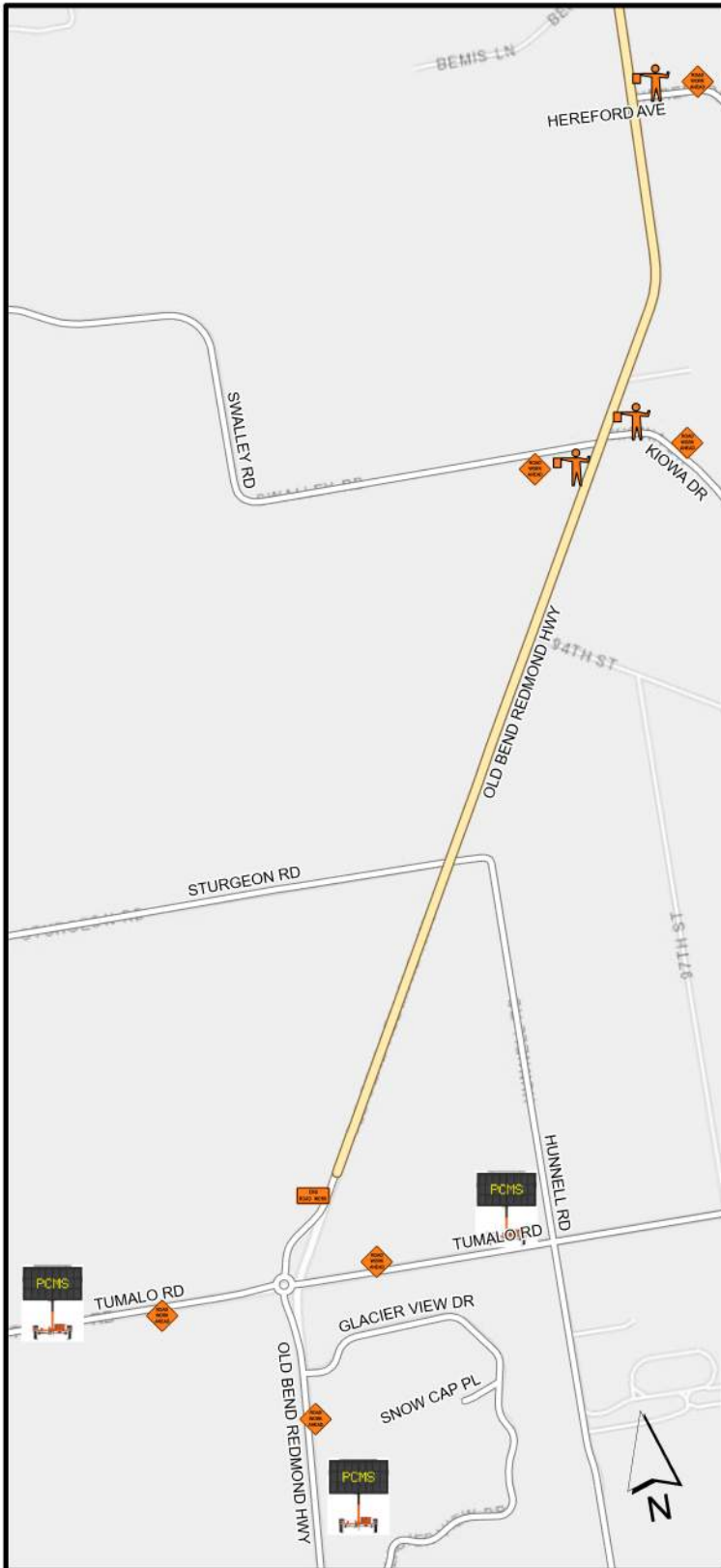

LEGEND

-  PROJECT CENTERLINE
-  COUNTY ROUTES
-  END ROAD WORK
-  FLAGGER STATION
-  PCMS
-  PCMS
-  ROAD WORK AHEAD

NOTES

- INSTALL FLAGGER ADV. WARNING SIGNAGE ACCORDING TO TM855.
- PLACE FLAGGER STATIONS ON SIDE ROADS WITHIN WORK ZONE AS NEEDED. WORK ZONE LENGTH LIMITED TO 1 MILE.
- PROVIDE ABRUPT EDGE SIGNAGE AS REQ'D WITHIN WORK ZONE LIMITS.
- INSTALL WAIT FOR PILOT CAR SIGNS AT MINOR ROAD APPROACHES AND DRIVEWAYS WITHIN WORK ZONE LIMITS.
- INSTALL PCMS 14 DAYS IN ADVANCE OF CONSTRUCTION. ADJUST PCMS THROUGHOUT PROJECT AS DIRECTED.



ROAD DEPARTMENT

PLAN: TEMPORARY TRAFFIC CONTROL PLAN

SHEET NO: 25 of 26

DATE: 3/27/2024

SCALE: N.T.S.

DRAFTER: R. PINKSTON
REVIEWED BY: C. SMITH

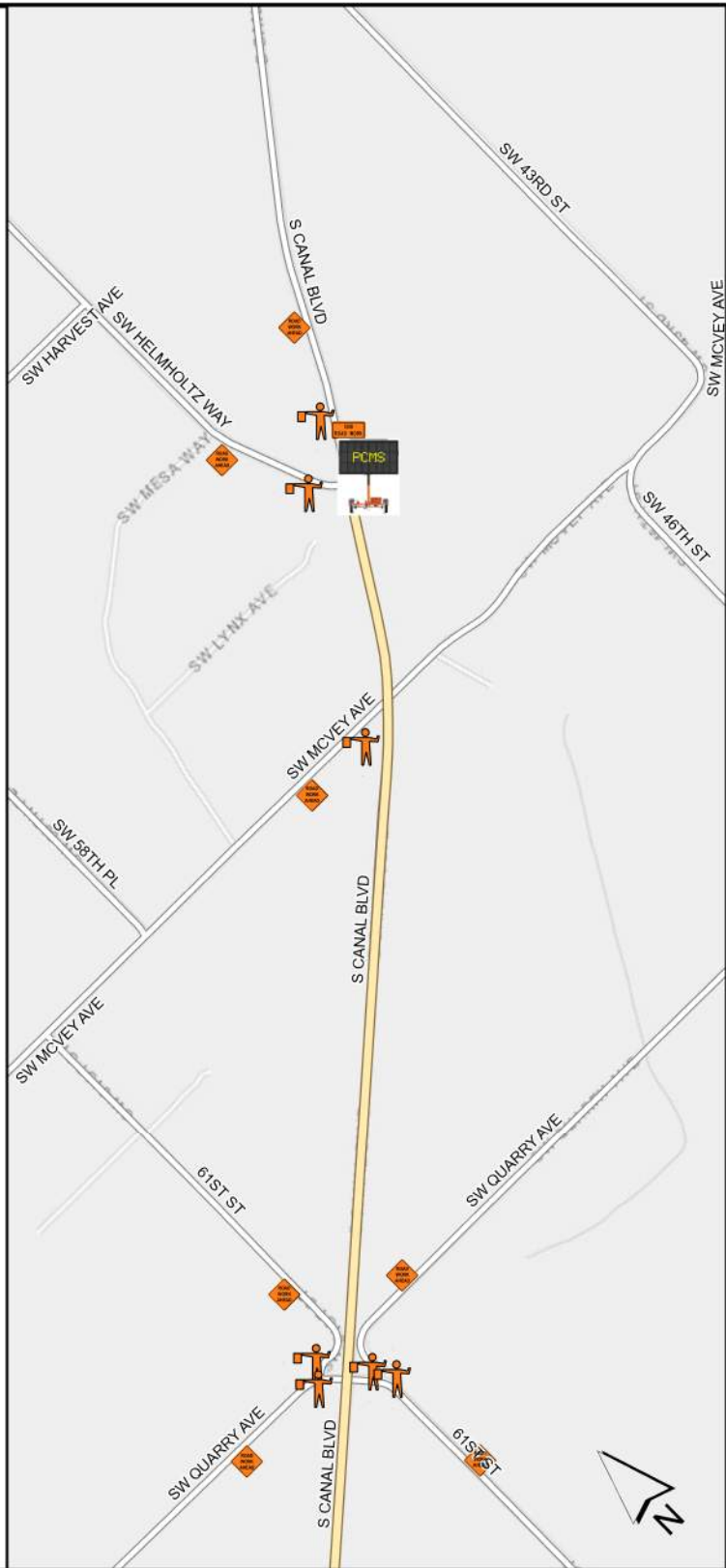
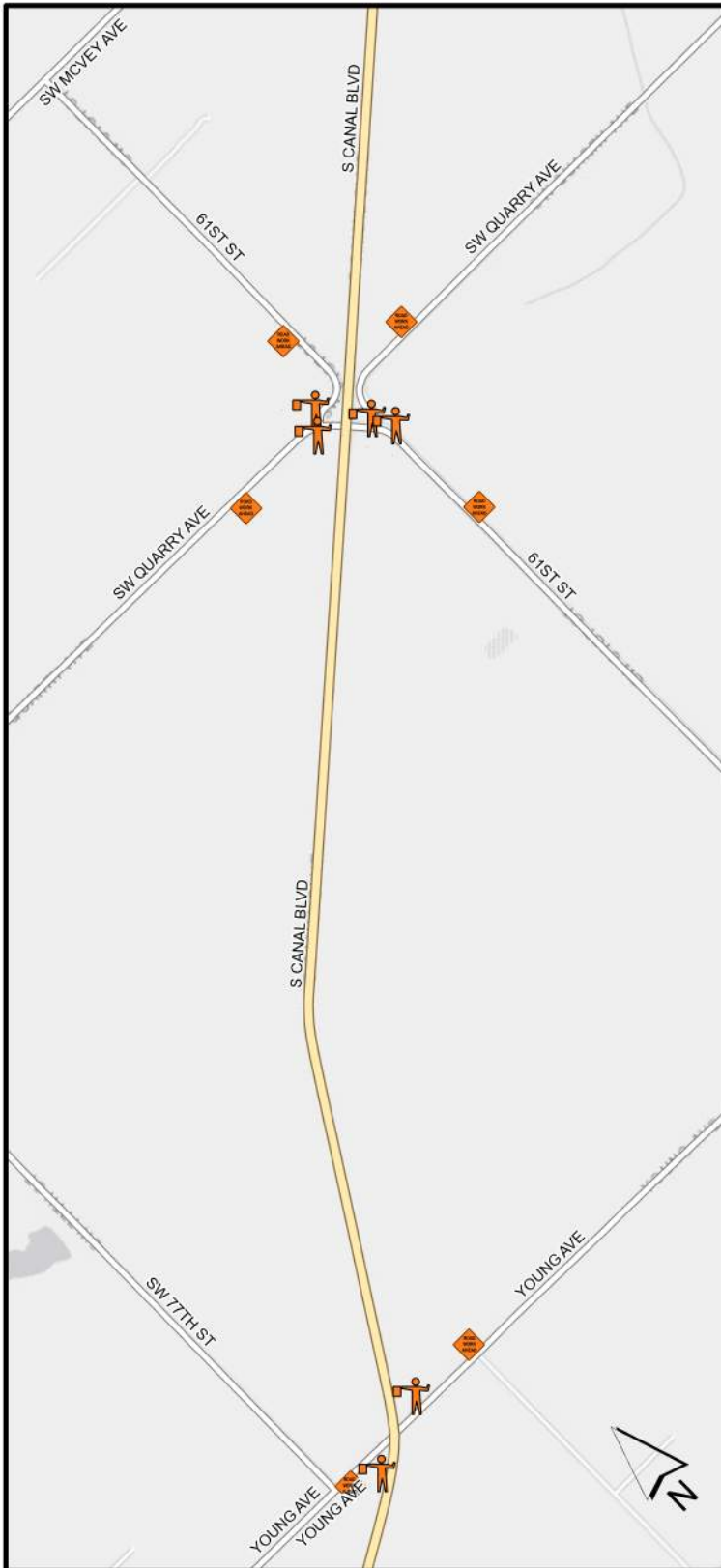

LEGEND

- COUNTY ROUTES
- PROJECT CENTERLINE
- END ROAD WORK
- FLAGGER STATION
- PCMS
- ROAD WORK AHEAD

NOTES

- INSTALL FLAGGER ADV. WARNING SIGNAGE ACCORDING TO TM855.
- PLACE FLAGGER STATIONS ON SIDE ROADS WITHIN WORK ZONE AS NEEDED. WORK ZONE LENGTH LIMITED TO 1 MILE.
- PROVIDE ABRUPT EDGE SIGNAGE AS REQ'D WITHIN WORK ZONE LIMITS.
- INSTALL WAIT FOR PILOT CAR SIGNS AT MINOR ROAD APPROACHES AND DRIVEWAYS WITHIN WORK ZONE LIMITS.
- INSTALL PCMS 14 DAYS IN ADVANCE OF CONSTRUCTION. ADJUST PCMS THROUGHOUT PROJECT AS DIRECTED.



ROAD DEPARTMENT

PLAN: TEMPORARY TRAFFIC CONTROL PLAN

SHEET NO: 26 of 26

DATE: 3/27/2024

SCALE: N.T.S.

DRAFTER: R. PINKSTON
REVIEWED BY: C. SMITH

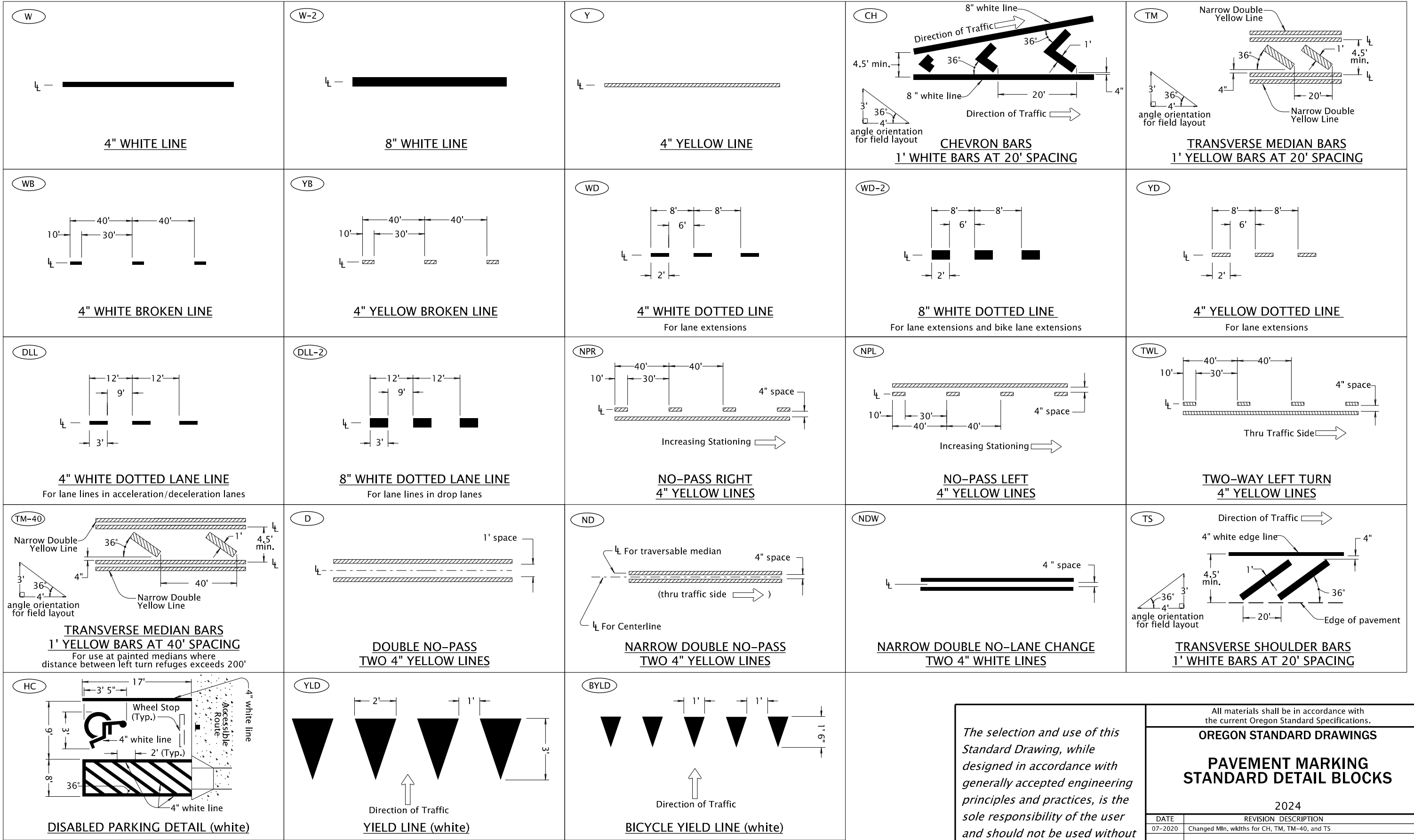

← Direction Of Traffic, Increasing Stationing Or Thru Traffic Side

⊥ — Lane line dimensions are shown on the striping plans

LEGEND

The selection and use of this Standard Drawing, while designed in accordance with generally accepted engineering principles and practices, is the sole responsibility of the user and should not be used without first consulting a Registered Professional Engineer.

All materials shall be in accordance with the current Oregon Standard Specifications.	
OREGON STANDARD DRAWINGS	
PAVEMENT MARKING STANDARD DETAIL BLOCKS	
2024	
DATE	REVISION DESCRIPTION
07-2020	Changed Min. widths for CH, TM, TM-40, and TS
CALC. BOOK NO.	SDR DATE
N/A	07-01-2020
TM500	

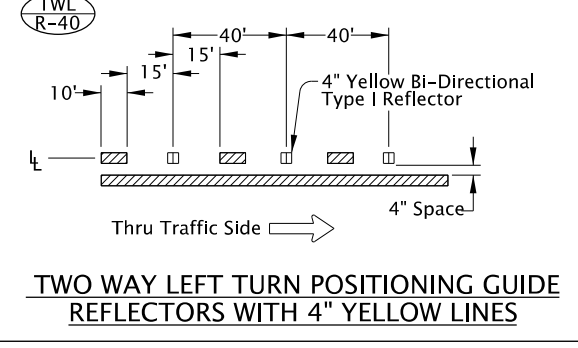
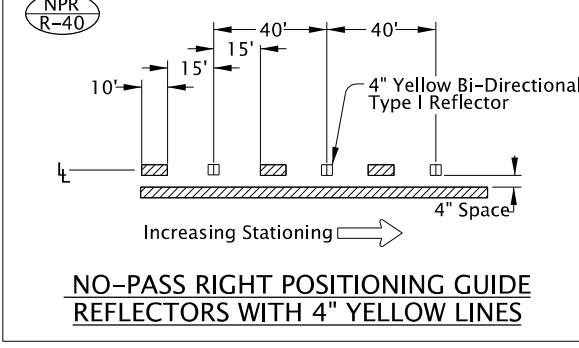
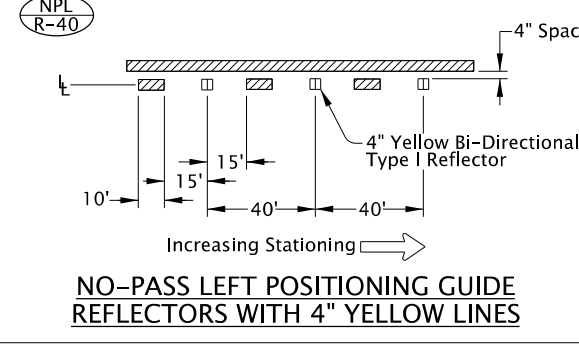
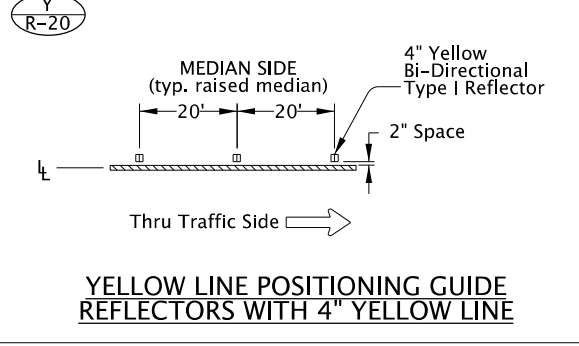
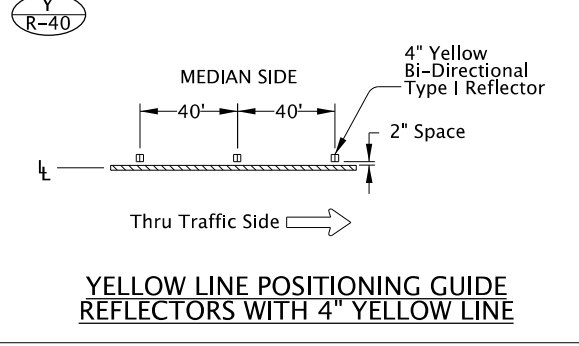
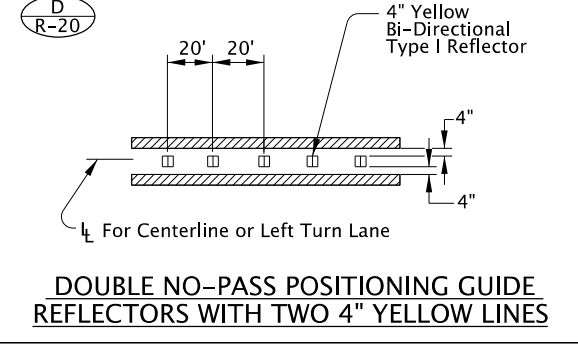
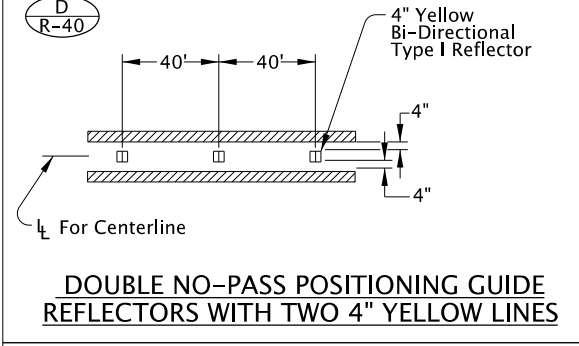
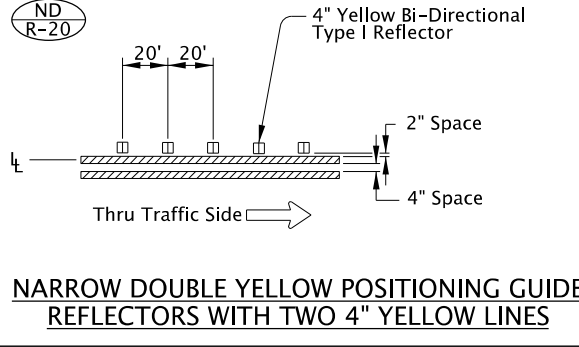
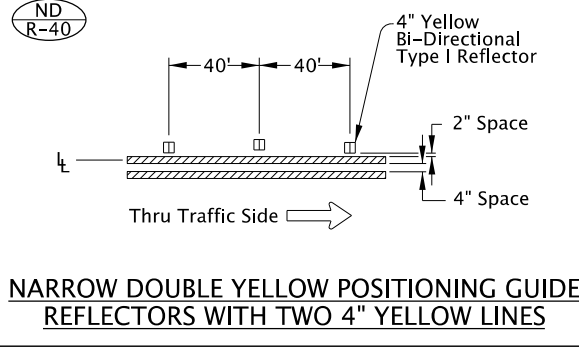
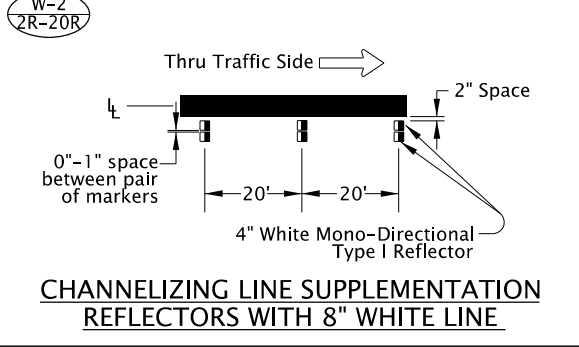
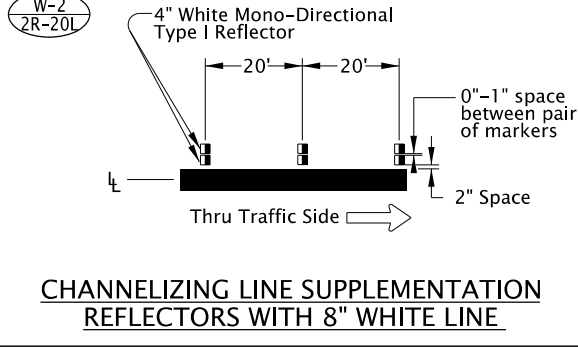
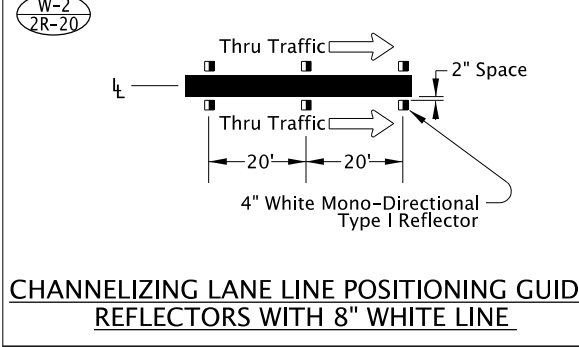
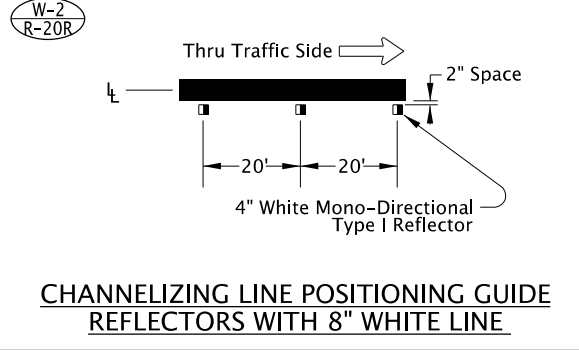
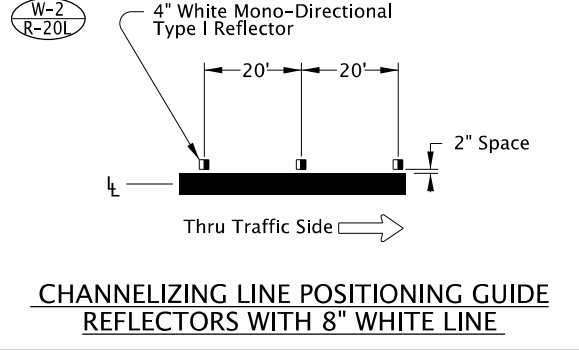
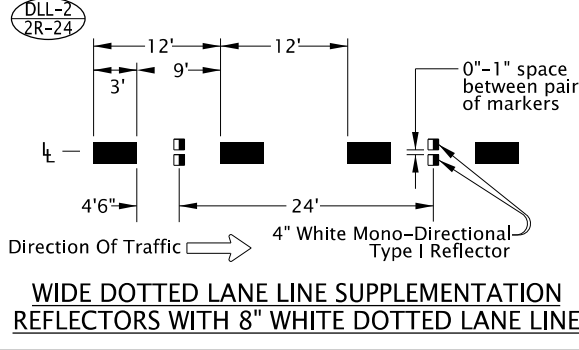
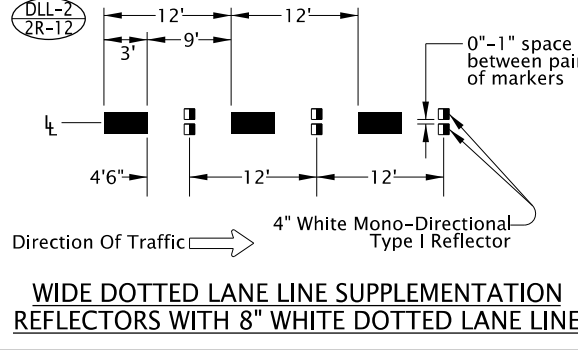
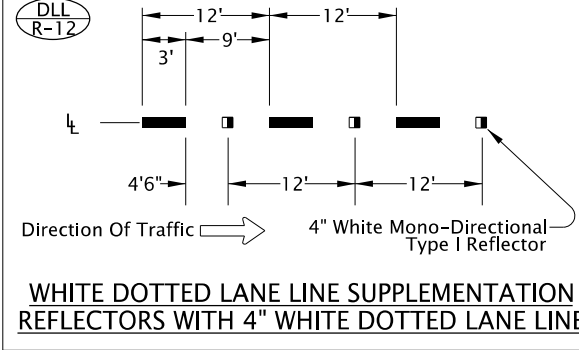
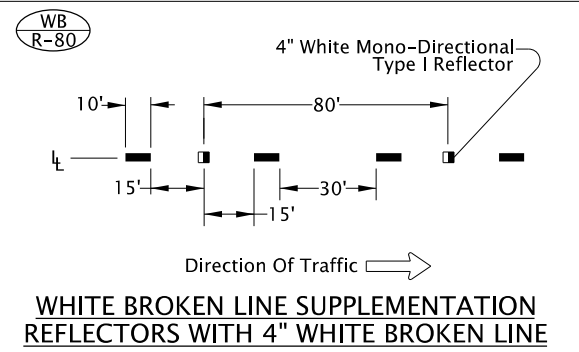
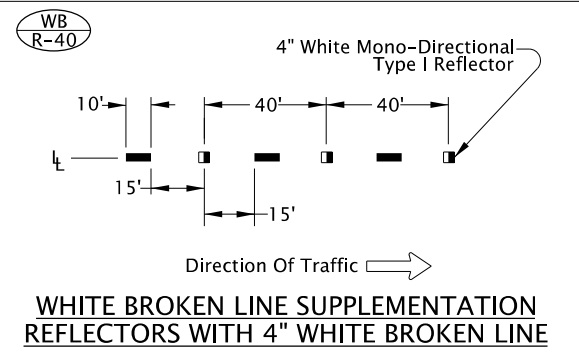
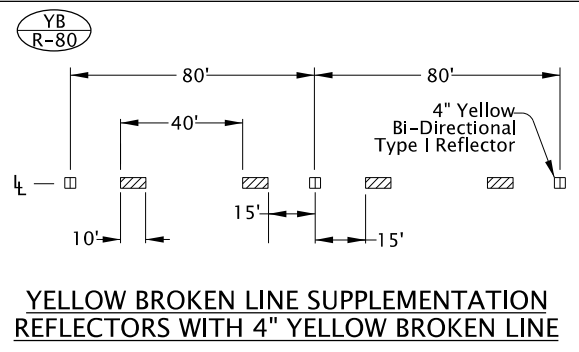
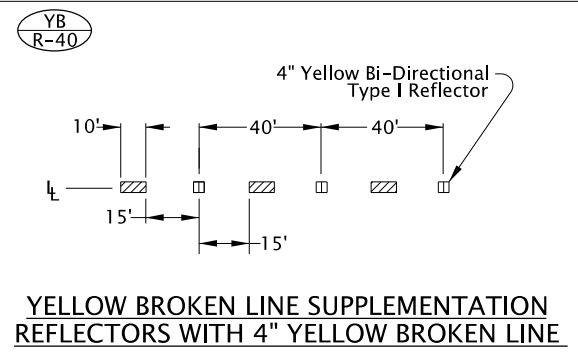
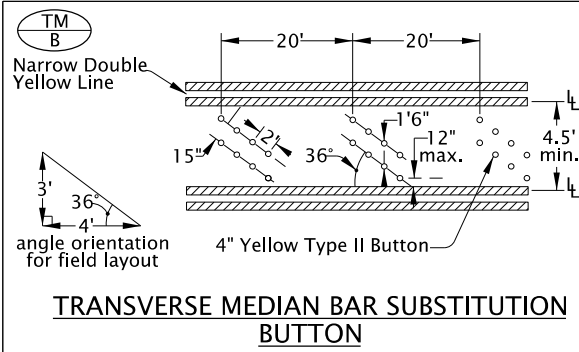

General note:
1) Surface mount Raised Pavement Markers (RPMs) unless otherwise specified.

- LEGEND**
- ← Direction Of Travel, Increasing Stationing or Thru Traffic Side
 - ⊥ Lane line dimensions are shown on the striping plans
 - Mono-directional crystal white marker reflects white to the left in this symbol
 - Bi-directional yellow marker reflects yellow both left and right in this symbol

The selection and use of this Standard Drawing, while designed in accordance with generally accepted engineering principles and practices, is the sole responsibility of the user and should not be used without first consulting a Registered Professional Engineer.

All materials shall be in accordance with the current Oregon Standard Specifications.

OREGON STANDARD DRAWINGS

PAVEMENT MARKING STANDARD DETAIL BLOCKS

2024

DATE	REVISION	DESCRIPTION
07-2020	Changed min. width of TM/B from 6' to 4.5'	
01-2022	Removed "LANE" from W-2/R-20R title	

CALC. BOOK NO. - - -	N/A - - -	SDR DATE - 01-03-2022	TM502
----------------------	-----------	-----------------------	--------------

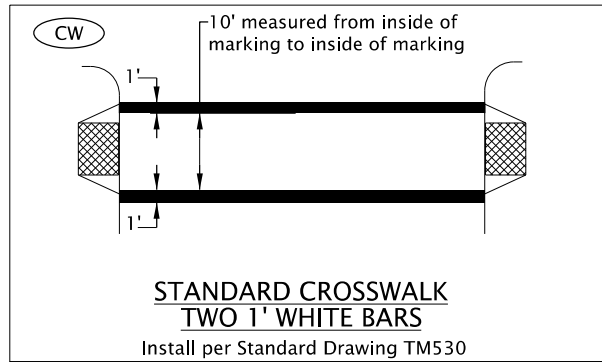

STANDARD CROSSWALK
TWO 1' WHITE BARS
Install per Standard Drawing TM530

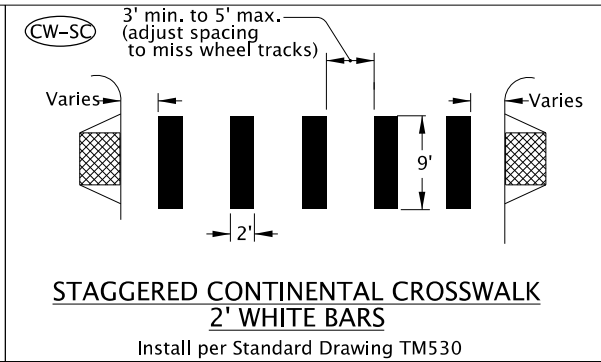

STAGGERED CONTINENTAL CROSSWALK
2' WHITE BARS
Install per Standard Drawing TM530

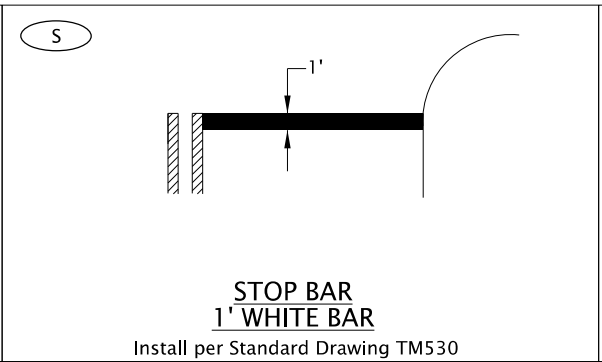

STOP BAR
1' WHITE BAR
Install per Standard Drawing TM530

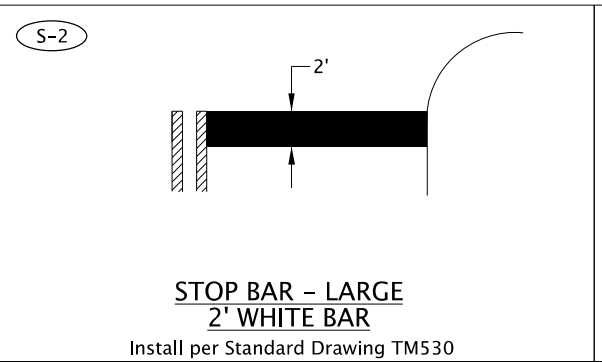

STOP BAR - LARGE
2' WHITE BAR
Install per Standard Drawing TM530

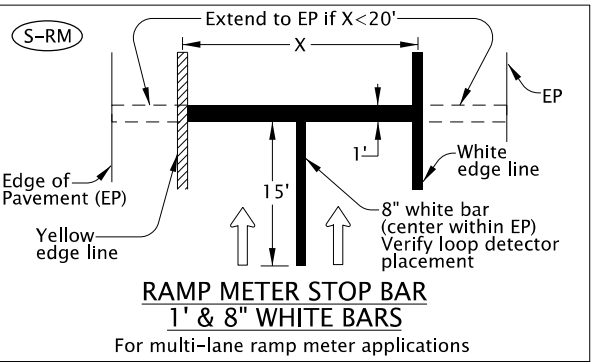

RAMP METER STOP BAR
1' & 8" WHITE BARS
For multi-lane ramp meter applications

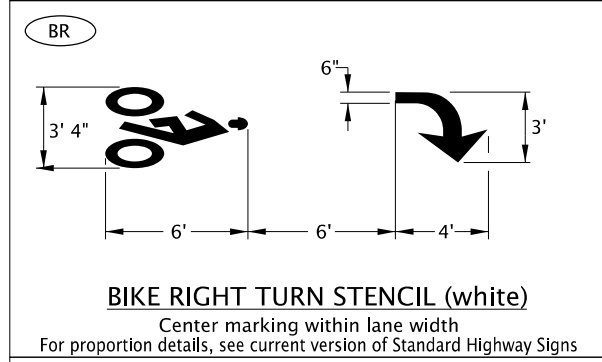

BIKE RIGHT TURN STENCIL (white)
Center marking within lane width
For proportion details, see current version of Standard Highway Signs

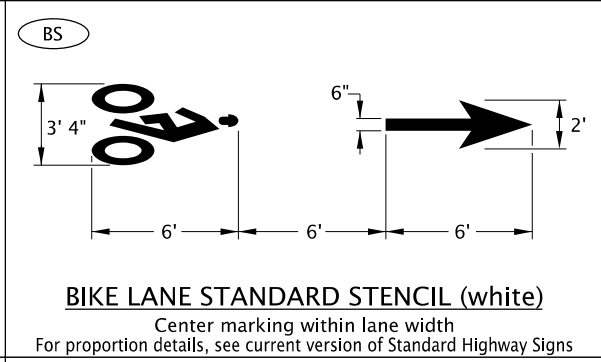

BIKE LANE STANDARD STENCIL (white)
Center marking within lane width
For proportion details, see current version of Standard Highway Signs

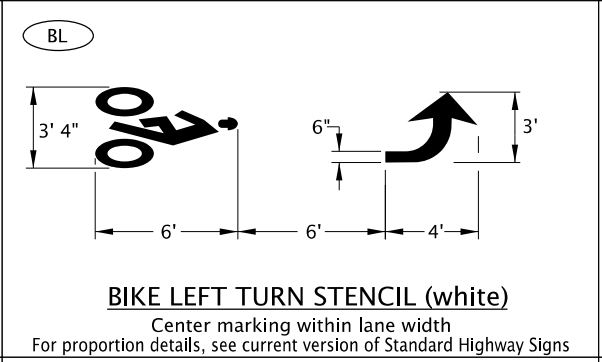

BIKE LEFT TURN STENCIL (white)
Center marking within lane width
For proportion details, see current version of Standard Highway Signs

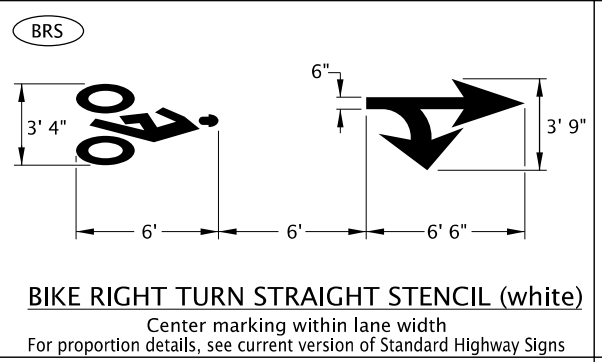

BIKE RIGHT TURN STRAIGHT STENCIL (white)
Center marking within lane width
For proportion details, see current version of Standard Highway Signs

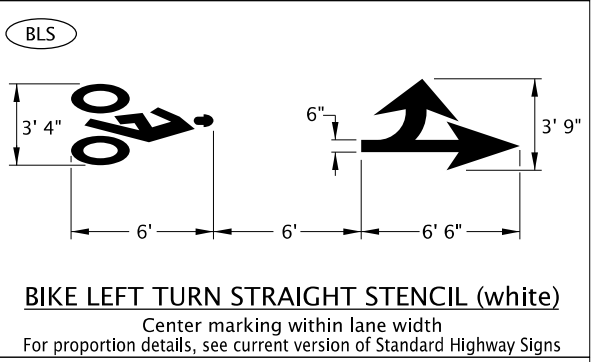

BIKE LEFT TURN STRAIGHT STENCIL (white)
Center marking within lane width
For proportion details, see current version of Standard Highway Signs

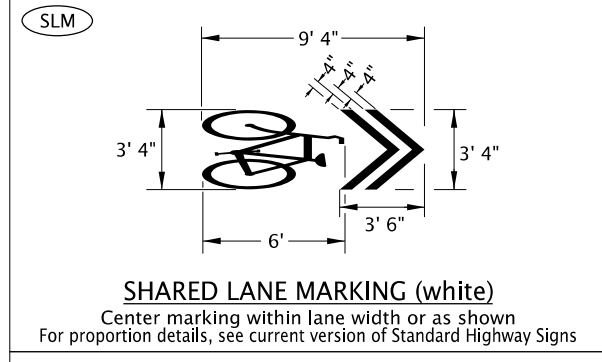

SHARED LANE MARKING (white)
Center marking within lane width or as shown
For proportion details, see current version of Standard Highway Signs

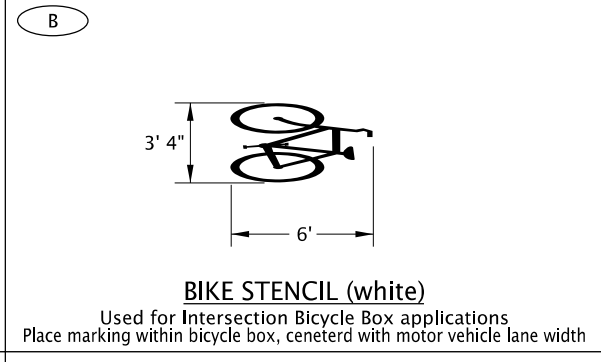

BIKE STENCIL (white)
Used for Intersection Bicycle Box applications
Place marking within bicycle box, centered with motor vehicle lane width

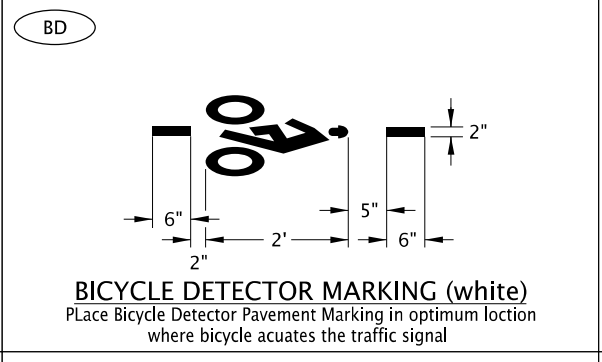

BICYCLE DETECTOR MARKING (white)
Place Bicycle Detector Pavement Marking in optimum location where bicycle acuates the traffic signal

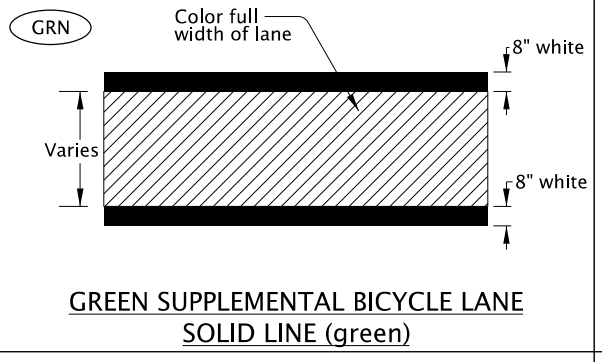

GREEN SUPPLEMENTAL BICYCLE LANE
SOLID LINE (green)

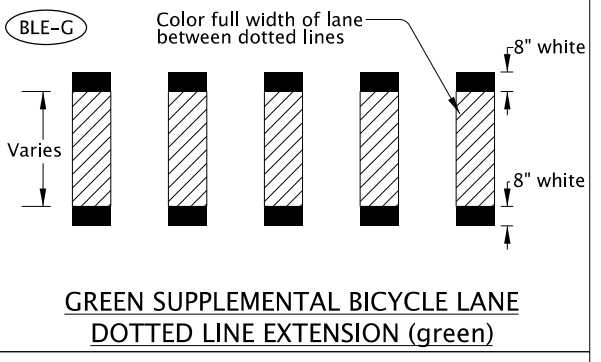

GREEN SUPPLEMENTAL BICYCLE LANE
DOTTED LINE EXTENSION (green)

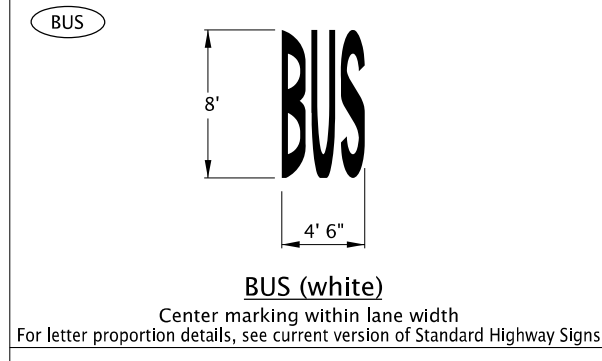

BUS (white)
Center marking within lane width
For letter proportion details, see current version of Standard Highway Signs

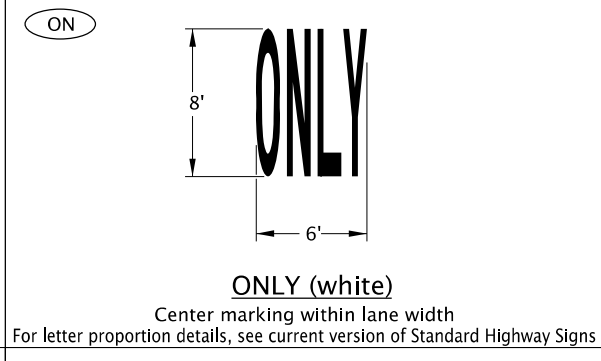

ONLY (white)
Center marking within lane width
For letter proportion details, see current version of Standard Highway Signs

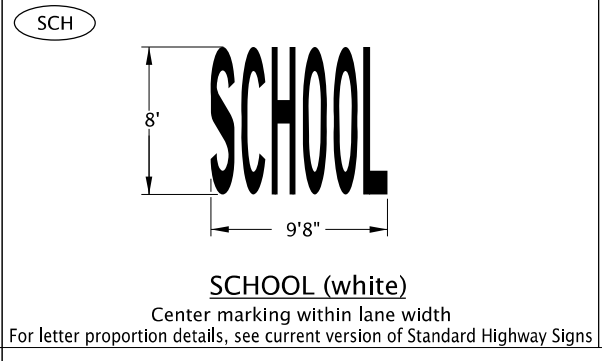

SCHOOL (white)
Center marking within lane width
For letter proportion details, see current version of Standard Highway Signs

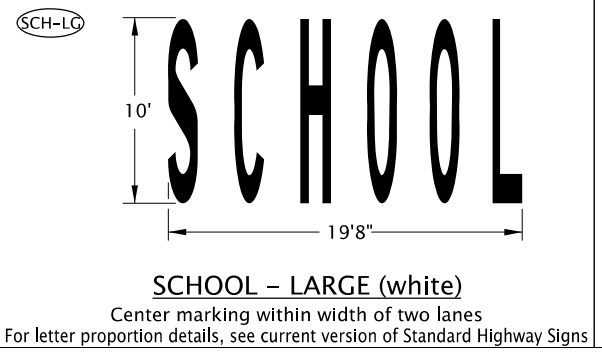

SCHOOL - LARGE (white)
Center marking within width of two lanes
For letter proportion details, see current version of Standard Highway Signs

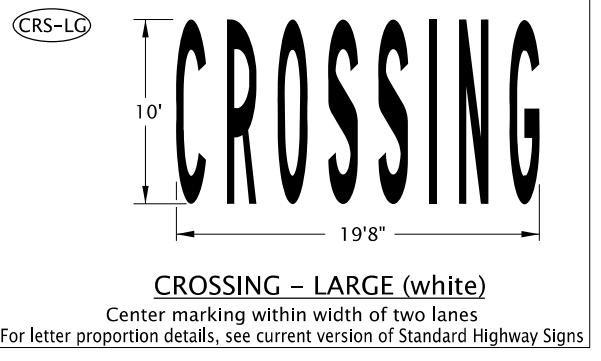

CROSSING - LARGE (white)
Center marking within width of two lanes
For letter proportion details, see current version of Standard Highway Signs

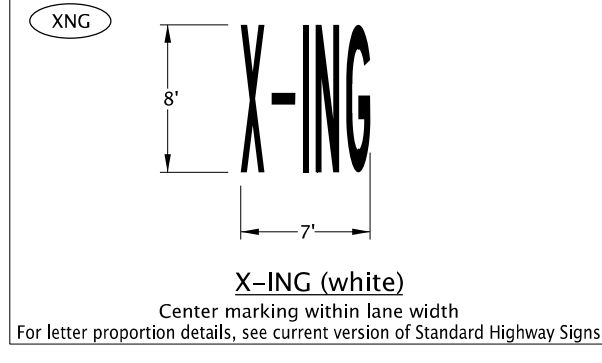

X-ING (white)
Center marking within lane width
For letter proportion details, see current version of Standard Highway Signs

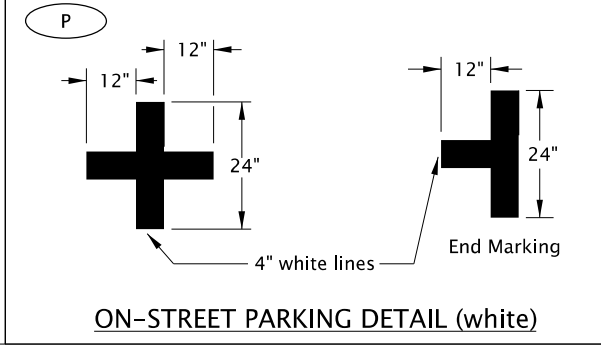

ON-STREET PARKING DETAIL (white)

General Note:
1. Arrow, letter, and bike symbol dimensions nominal.

LEGEND
← Direction of Travel

The selection and use of this Standard Drawing, while designed in accordance with generally accepted engineering principles and practices, is the sole responsibility of the user and should not be used without first consulting a Registered Professional Engineer.

All materials shall be in accordance with the current Oregon Standard Specifications.		
OREGON STANDARD DRAWINGS		
PAVEMENT MARKING		
STANDARD DETAIL BLOCKS		
2024		
DATE	REVISION DESCRIPTION	
07-2022	Added note for measurement of Standard Crosswalk	
CALC. BOOK NO.	N/A	SDR DATE
		07-08-2022
		TM503

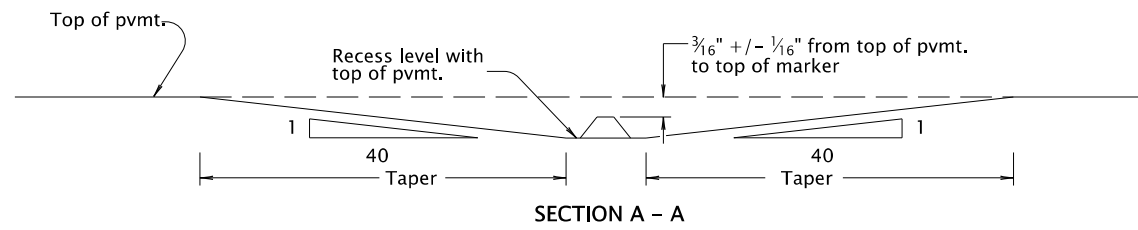
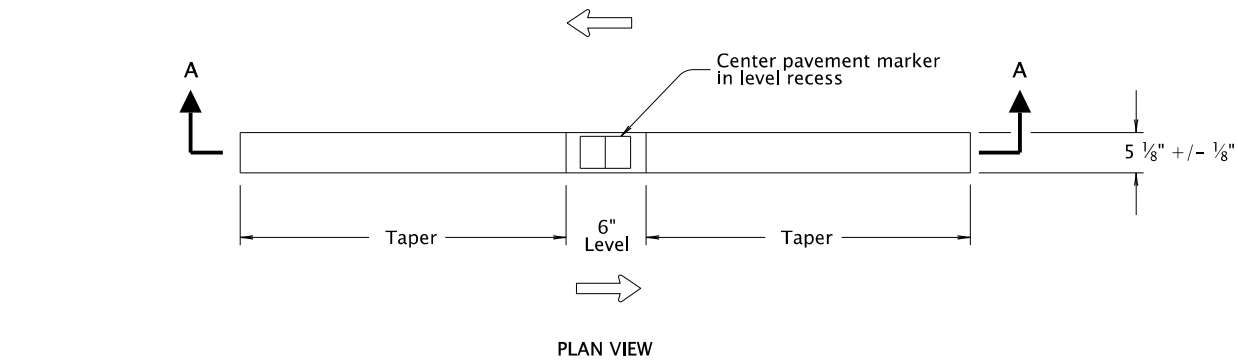

BI-DIRECTIONAL RECESSED PAVEMENT MARKER DETAIL

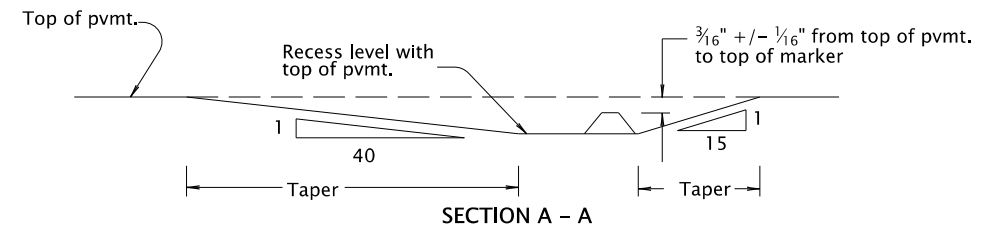
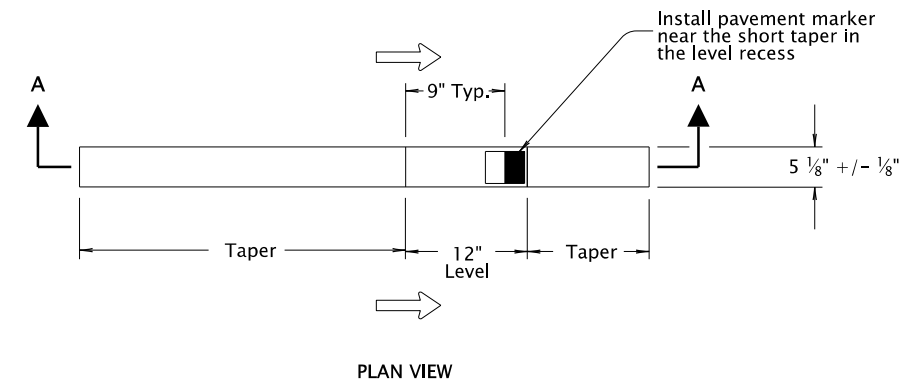

MONO-DIRECTIONAL RECESSED PAVEMENT MARKER DETAIL

LEGEND

- ← Direction of Travel
- Bi-directional yellow marker reflects yellow both left and right in this symbol
- Mono-directional crystal white marker reflects white to the left in this symbol

To be accompanied by Standard Dwg. Nos. TM502 and TM515

The selection and use of this Standard Drawing, while designed in accordance with generally accepted engineering principles and practices, is the sole responsibility of the user and should not be used without first consulting a Registered Professional Engineer.

All materials shall be in accordance with the current Oregon Standard Specifications.

OREGON STANDARD DRAWINGS

RECESSED PAVEMENT MARKERS

2024

DATE	REVISION	DESCRIPTION
07-2021		Updated to better fit ODOT drafting standards
CALC. BOOK NO.	N/A	SDR DATE

TM517

Effective Date: December 1, 2023 - May 31, 2024

06-JUL-2022

TM530.dgn

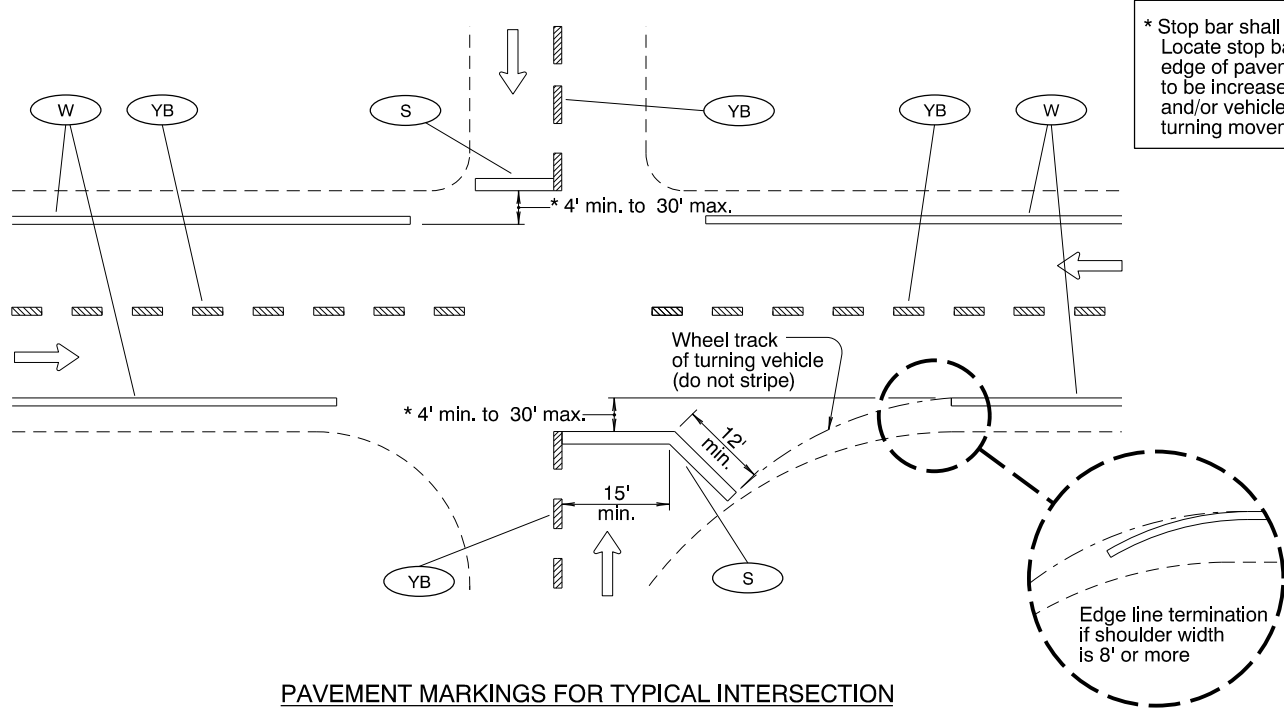

PAVEMENT MARKINGS FOR TYPICAL INTERSECTION

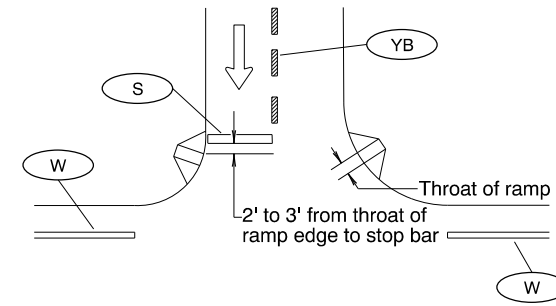

Detail "A"
STOP BAR PLACEMENT WITH
RESPECT TO PEDESTRIAN RAMP

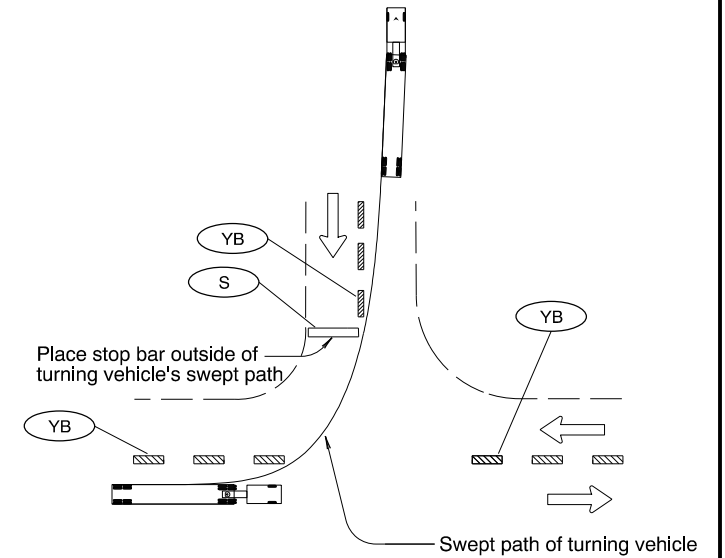

Detail "B"
STOP BAR PLACEMENT WITH
RESPECT TO TURN RADII

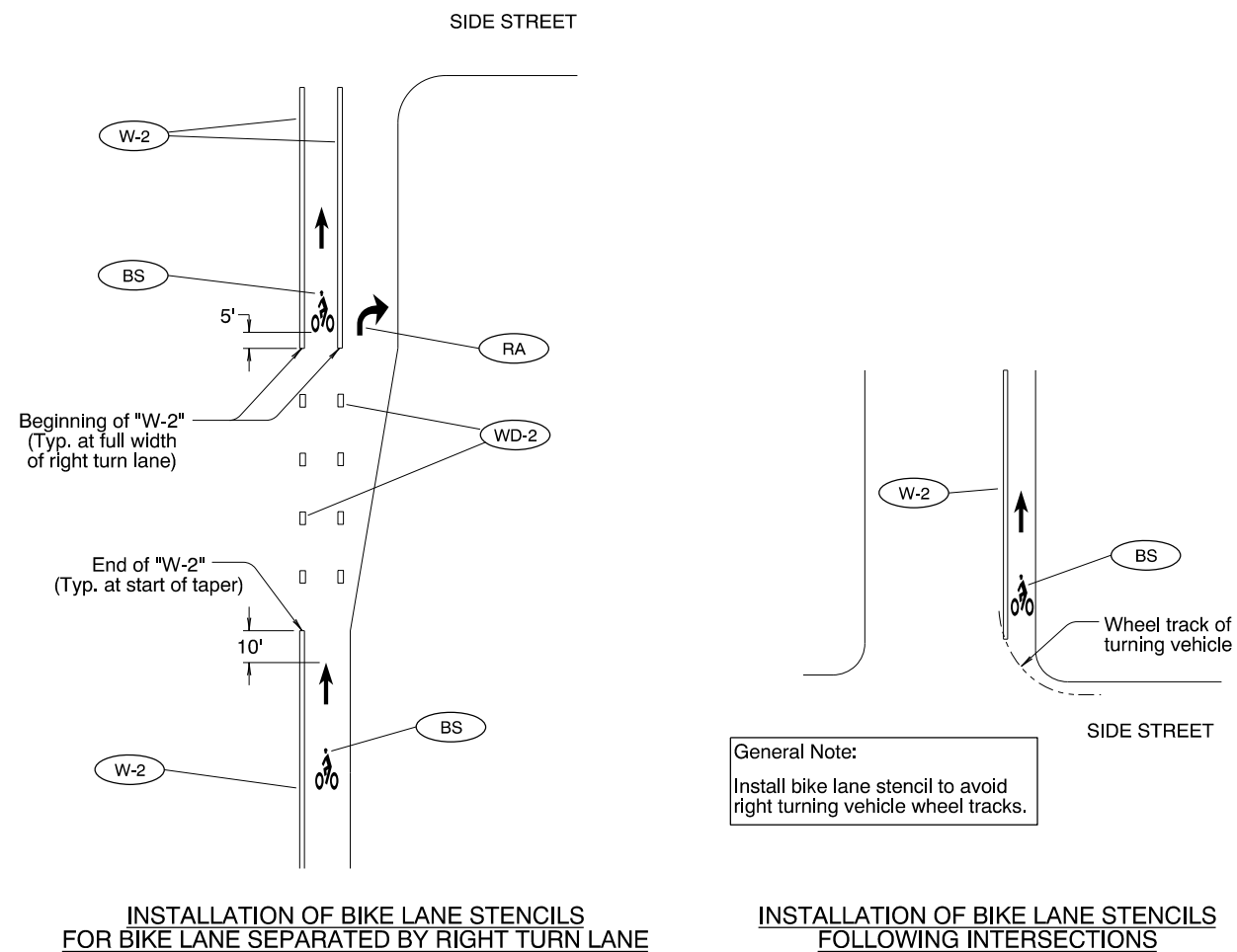

INSTALLATION OF BIKE LANE STENCILS
FOR BIKE LANE SEPARATED BY RIGHT TURN LANE

INSTALLATION OF BIKE LANE STENCILS
FOLLOWING INTERSECTIONS

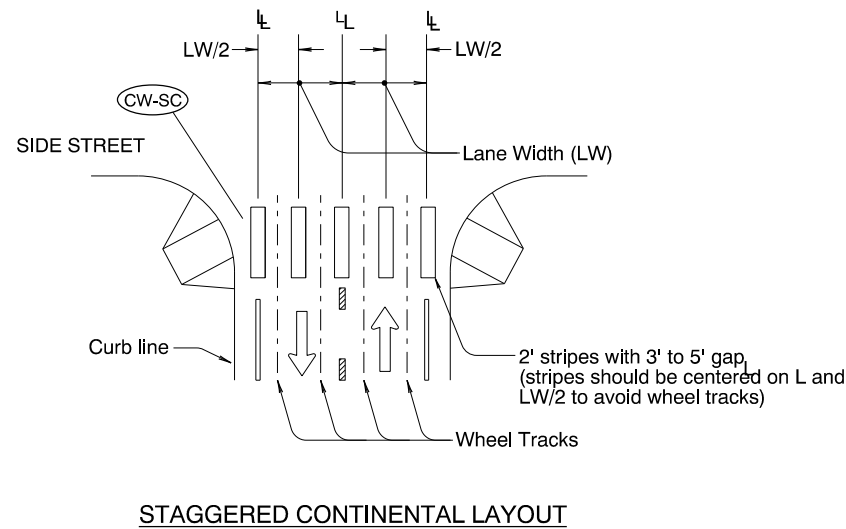

STAGGERED CONTINENTAL LAYOUT

General Note:
1. Install crosswalk bars such that the throat of the ADA ramp is entirely within crosswalk markings, or 5' back of extended fog line, edge of pavement, or curb face.

LEGEND
← Direction of Travel
L - Lane line dimensions are shown on the striping plans

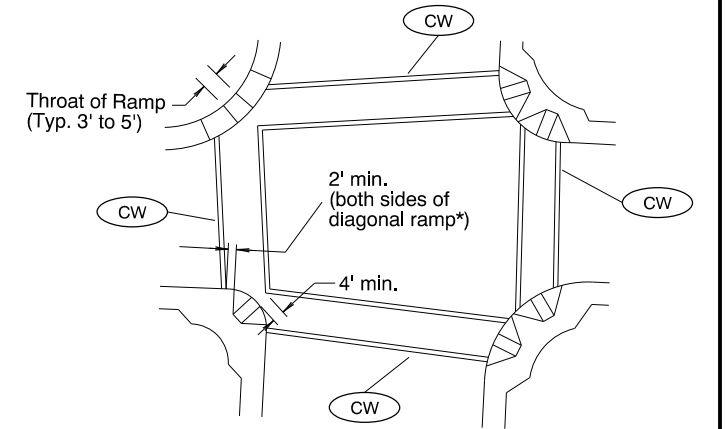

STANDARD CROSSWALK BARS
AT INTERSECTION

* = Refer to Std Dwg RD916

To be accompanied by Standard Dwg. Nos. TM500 thru TM504

The selection and use of this Standard Drawing, while designed in accordance with generally accepted engineering principles and practices, is the sole responsibility of the user and should not be used without first consulting a Registered Professional Engineer.

All materials shall be in accordance with the current Oregon Standard Specifications.	
OREGON STANDARD DRAWINGS	
INTERSECTION PAVEMENT MARKINGS (CROSSWALK, STOP BAR & BIKE LANE STENCIL)	
2024	
DATE	REVISION DESCRIPTION
07-2022	Added Roadway Standard Drawing reference to detail for clarity
CALC. BOOK NO.	SDR DATE
N/A	06-JUL-2022
TM530	

Effective Date: December 1, 2023 – May 31, 2024

07-01-2020
TM560.dgn

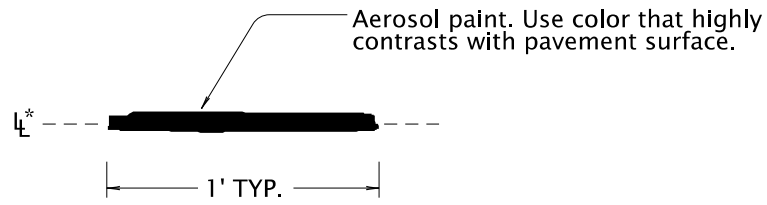

CONTROL POINT

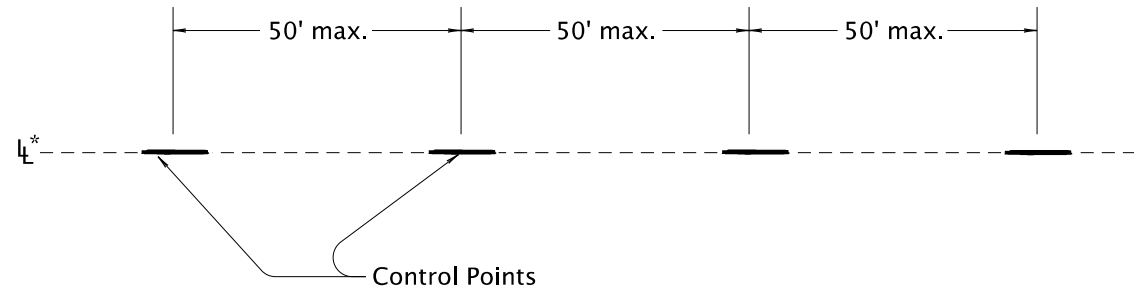

CONTROL POINT LAYOUT - TANGENT SECTIONS

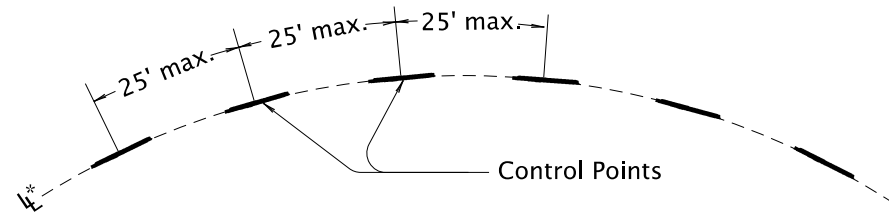

CONTROL POINT LAYOUT - CURVE SECTIONS

General note:

1.) Use control points to make continuous narrow guideline as specified.

* Control points are placed along the lane line for all longitudinal lines except the following:

ND For center lines only A control point layout 4" offset from the lane line is required for a ND line when used as a center line.

LEGEND

ℓ — Lane line dimensions are shown on the striping plans.

To be accompanied by Standard Dwg. Nos. TM500 thru TM504

<p><i>The selection and use of this Standard Drawing, while designed in accordance with generally accepted engineering principles and practices, is the sole responsibility of the user and should not be used without first consulting a Registered Professional Engineer.</i></p>		<p>All materials shall be in accordance with the current Oregon Standard Specifications.</p>	
		<p>OREGON STANDARD DRAWINGS</p>	
		<p>ALIGNMENT LAYOUT: GENERAL</p>	
		<p>2024</p>	
DATE	REVISION	DESCRIPTION	
07-2020		Extended accompanied by drawings to include TM504	
CALC. BOOK NO.	N/A	SDR DATE	07-01-2020
			TM560

Effective Date: December 1, 2023 – May 31, 2024

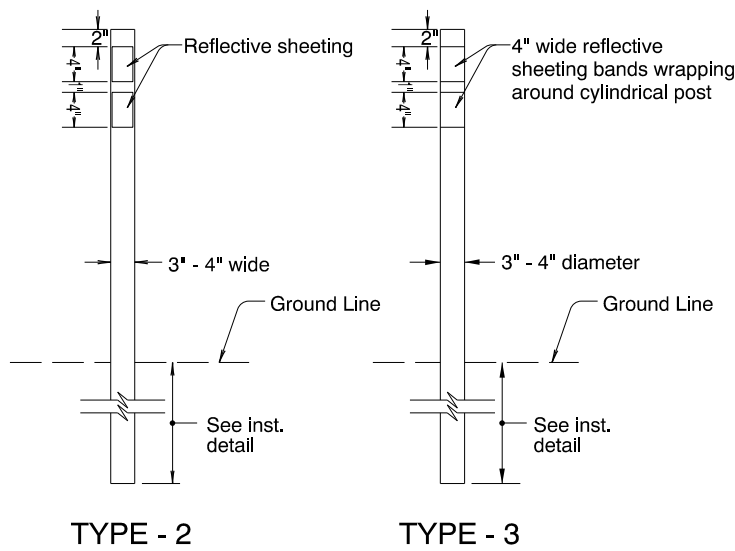

FLEXIBLE PLASTIC POSTS

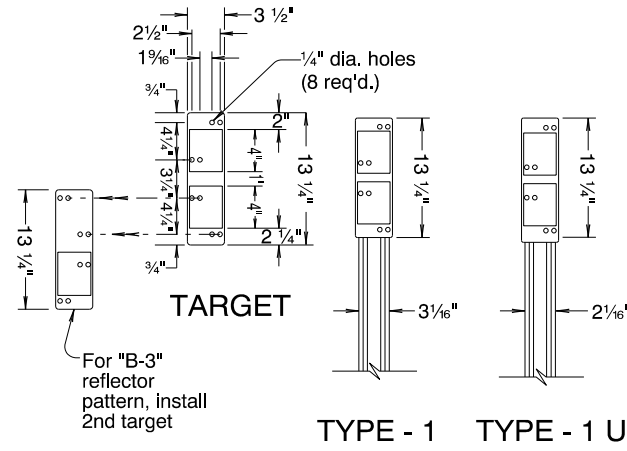

STEEL POSTS

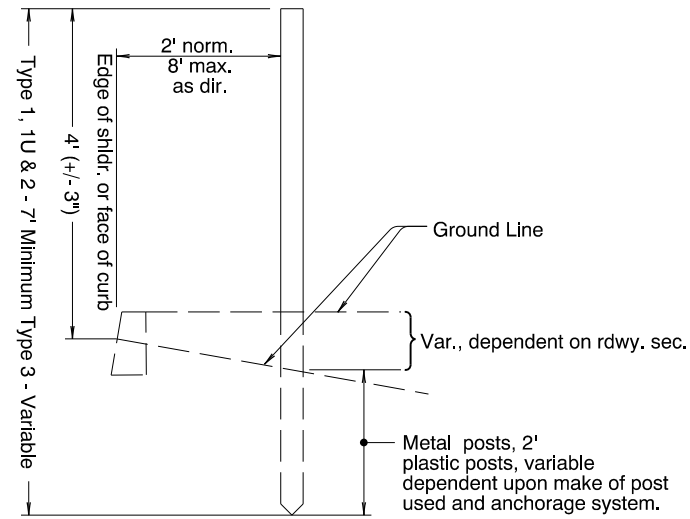

INSTALLATION DETAIL

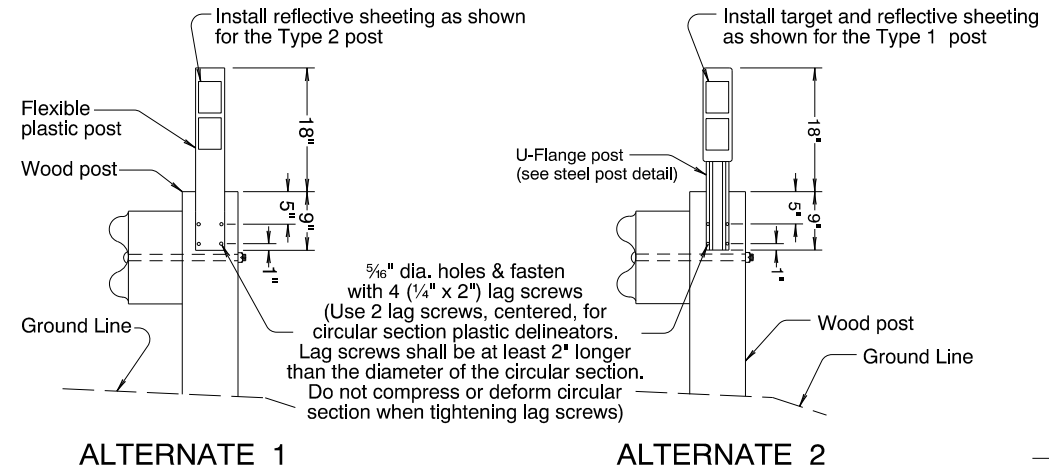

GUARDRAIL AREAS (WITH WOOD POSTS)

NOTES:

POST:
Galv. steel, nominal weight Type 1, 2 lb/ft, Type 1 U, 1.12 lb/ft.

See Standard Drawing TM571 for steel post dimensions and details.

TARGET:
Aluminum sheet, nominal thickness .050". Fasten to post with 3/16" dia. aluminum blind rivets and washers.

For "B-3" reflector pattern, top target shall overlap bottom target.

REFLECTORS:
3" x 4" reflective sheeting unless otherwise shown. (3 1/2" x 4" reflective sheeting is an acceptable alternate unless otherwise shown.)
Acrylic prismatic reflectors acceptable on Type 1, 1 U, 2 and 4 posts and Type 5 barrier mounts.
Place required number in sequence from top of target.

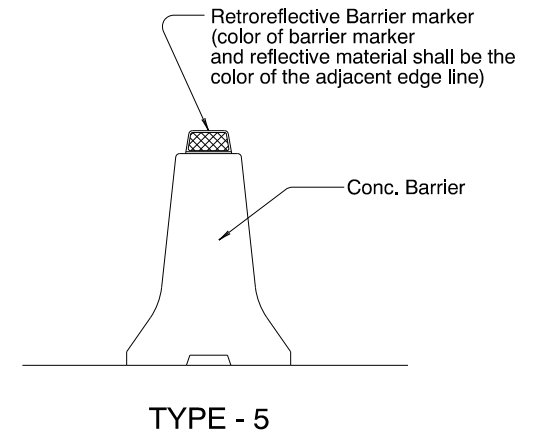

CONCRETE BARRIER AREAS

(Install barrier markers at 50' spacing unless otherwise noted in plans)

- GENERAL NOTES:**
- Spacing shall be measured along the shoulder.
 - On roads with less than 500 vehicle ADT, delineators are not to be used except where situations such as sharp horizontal curves, etc. exist.
 - To clear driveways, crossroads etc., or for required adjustments at ramps and at intersections, either:
 - vary placement of that post up to 25% of spacing shown, or;
 - eliminate said post if limit of variation must be exceeded.
 - Judgement should be exercised in the installation of delineators in cut section, particularly on roads constructed to older standards where ditches are narrow and where delineators tend to hamper maintenance operations.
 - On horizontal curves place delineators nearly opposite each other.
 - At guard rail locations the delineators are to be installed behind the rail and shall be located adjacent to guard rail posts as shown for Type 4 Delineators.
 - Install all delineators with reflectors facing adjacent oncoming traffic.
 - Offset delineators an additional 4' in areas of heavy snow removal operations.
 - Backside Delineators may be used in frequently snow plowed areas where use of snow poles is not justified. When Backside Delineators are specified, substitute "W-1" and "W-2" with "W-1B" and "W-2B" respectively, on Type 1 steel posts. Do not install Backside Delineators on one-way sections of roadway, freeways and ramps, or on radius sections.
 - Refer to TM 222 for bracket assembly details for Backside Reflector Pattern.

REFLECTOR PATTERN TABLE					
	Color Type	Color Of Reflector And Target Or Post	Number Of Reflectors	Color Of Reflector And Target Or Post On Backside	Number Of Reflectors On Backside
Standard Pattern	"W-1"	White	1	Not Applicable	Not Applicable
	"W-2"	White	2		
	"Y-1"	Yellow	1		
	"Y-2"	Yellow	2		
	"B-1"	Blue	1		
	"B-2"	Blue	2		
	"B-3"	Blue	3		
	"R-1"	Red	1		
Backside Pattern	"W-1B"	White	1	White	2
	"W-2B"	White	2	White	2

TANGENT ▲ MAX. SPACING EACH SIDE OF ROADWAY IN FEET	HORIZONTAL CURVES ▲ MAX. SPACING EACH SIDE OF ROADWAY IN FEET				
	DEGREE OF CURVE	ON CURVE	IN ADVANCE OF & BEYOND CURVE		
			FIRST SPACE	SECOND SPACE	THIRD SPACE
400	Lower Than 1	300	300	300	300
	1	230	300	300	300
	2	160	300	300	300
	3	130	260	300	300
	4	110	220	300	300
	5	100	200	300	300
	6	90	180	270	300
	7 - 8	80	160	240	300
	9 - 11	70	140	210	300
	12 - 16	60	120	180	300
	17 - 22	50	100	150	300
	23 - 34	40	80	120	240
	35 - 53	30	60	90	180
	54 & Higher	20	40	60	120

(Min. spacing 20 feet)
(▲ Install "W-1" reflective pattern unless otherwise noted. See Standard Drawings TM575 thru TM577 for spacing, layout, and reflective pattern of delineators at interchange ramps, channelized intersections, lane reductions, emergency escape ramps and freeway crossovers.)

DELINEATOR SPACING TABLE FOR TYPES 1, 1U, 2, and 4

To be accompanied by Drg. No. TM571, TM575, TM576, and/or TM577 as specified.

The selection and use of this Standard Drawing, while designed in accordance with generally accepted engineering principles and practices, is the sole responsibility of the user and should not be used without first consulting a Registered Professional Engineer.

All materials shall be in accordance with the current Oregon Standard Specifications.

OREGON STANDARD DRAWINGS

TRAFFIC DELINEATORS

2024

DATE	REVISION	DESCRIPTION

CALC. BOOK NO. - - -	N/A - - -	SDR DATE - 06-JAN-2012	TM570
----------------------	-----------	------------------------	--------------

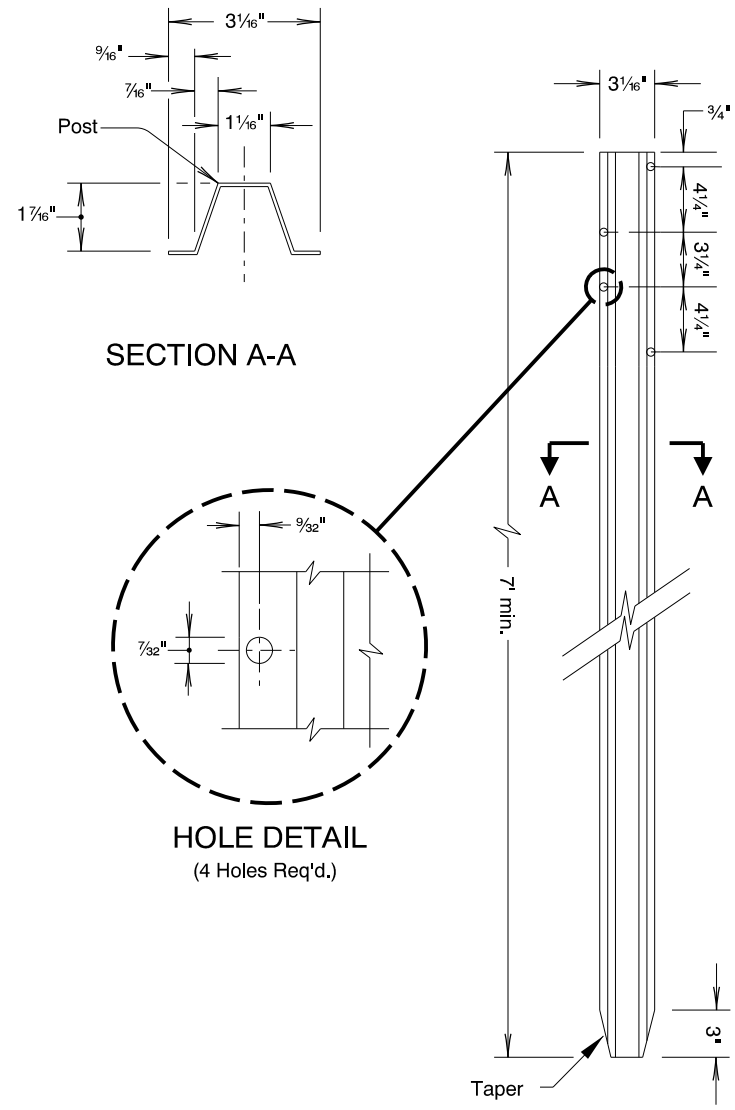

SECTION A-A

HOLE DETAIL
(4 Holes Req'd.)

- Notes:
- Galv. steel, nominal weight 2 lb. per ft.

TYPE - 1 STEEL POST DIMENSIONS

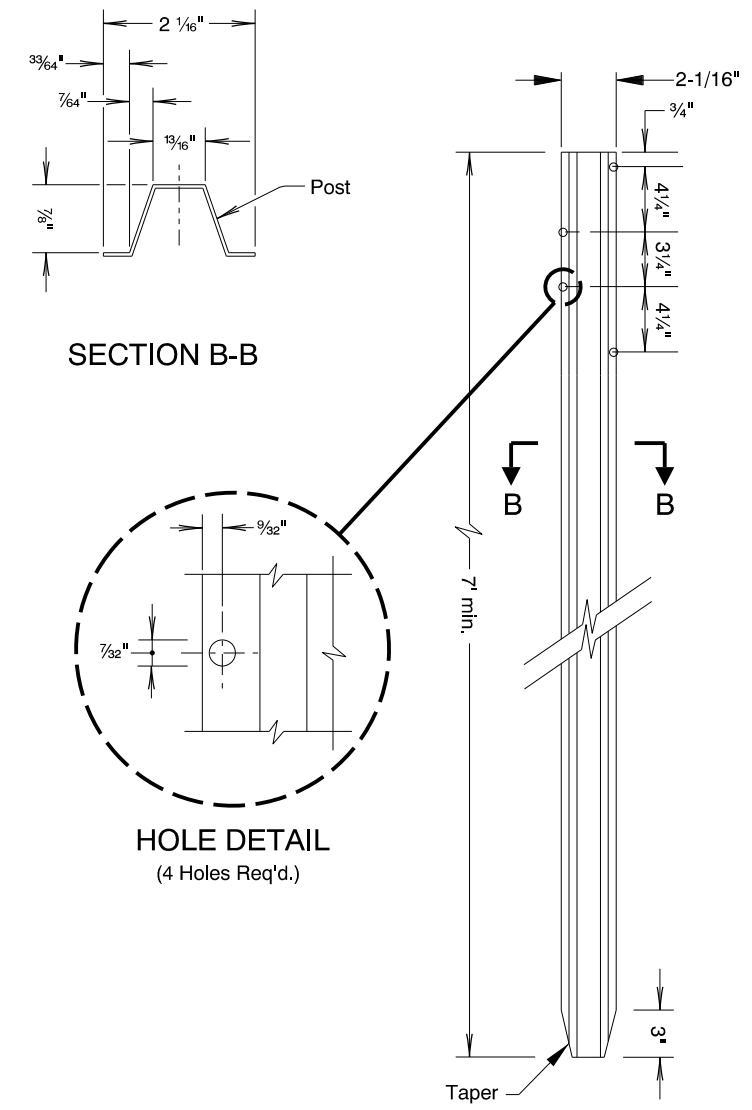

SECTION B-B

HOLE DETAIL
(4 Holes Req'd.)

- Notes:
- Galv. steel, nominal weight 1.12 lb. per ft.

TYPE - 1 U STEEL POST DIMENSIONS

To be accompanied by Drg. No. TM570

<p><i>The selection and use of this Standard Drawing, while designed in accordance with generally accepted engineering principles and practices, is the sole responsibility of the user and should not be used without first consulting a Registered Professional Engineer.</i></p>		<p>All materials shall be in accordance with the current Oregon Standard Specifications.</p>	
		<p>OREGON STANDARD DRAWINGS</p> <p>TRAFFIC DELINEATORS</p> <p>STEEL POST DETAILS</p> <p>2024</p>	
DATE		REVISION	DESCRIPTION
CALC. BOOK NO.	N/A	SDR DATE	10-DEC-2009
			TM571

TAPER TYPES & FORMULAS	
TAPER	FORMULA
Merging (Lane Closure)	"L"
Shifting	"L"/2 or 1/2"L"
Shoulder Closure	"L"/3 or 1/3"L"
Flagging (See Drg. TM850)	50' - 100'
Downstream (Termination)	Varies (See Drawings)

★ Use Pre-Construction Posted Speed to select the Speed from the Tables below:

TEMPORARY BARRIER FLARE RATE TABLE	
★ SPEED (mph)	MINIMUM FLARE RATE
≤ 30	8:1
35	9:1
40	10:1
45	12:1
50	14:1
55	16:1
60	18:1
65	19:1
70	20:1

MINIMUM LENGTHS TABLE					
"L" VALUE FOR TAPERS (ft)					BUFFER "B" (ft)
★ SPEED (mph)	W = Lane or Shoulder Width being closed or shifted				
	W ≤ 10	W = 12	W = 14	W = 16	
25	105	125	145	165	75
30	150	180	210	240	100
35	205	245	285	325	125
40	265	320	375	430	150
45	450	540	630	720	180
50	500	600	700	800	210
55	550	660	770	880	250
60	600	720	840	960	285
65	650	780	910	1000	325
70	700	840	980	1000	365
FREEWAYS					
55	1000	1000	1000	1000	250
60	1000	1000	1000	1000	285
65	1000	1000	1000	1000	325
70	1000	1000	1000	1000	365

- NOTES:
- For Lane closures where W < 10', use "L" value for W = 10'.
 - For Shoulder closures where W < 10', use "L" value for W = 10' or calculate "L" using formula, for Speeds ≥ 45: L = WS, Speeds < 45: L = S²W/60, S = Speed, W=Width

TRAFFIC CONTROL DEVICES (TCD) SPACING TABLE				
★ SPEED (mph)	Sign Spacing (ft)			Max. Channelizing Device Spacing (ft)
	A	B	C	
20 - 30	100	100	100	20
35 - 40	350	350	350	20
45 - 55	500	500	500	40
60 - 70	700	700	700	40
Freeway	1000	1500	2640	40

- NOTES:
- Place traffic control devices on 10 ft. spacing for intersection and access radii.
 - When necessary, sign spacing may be adjusted to fit site conditions. Limit spacing adjustments to 30% of the "A" dimension for all speeds.

- NOTES:
- When paved shoulders adjacent to excavations are less than four feet wide protect longitudinal abrupt edge as shown.
 - Use aggregate wedge when abrupt edge is 2 inches or greater.

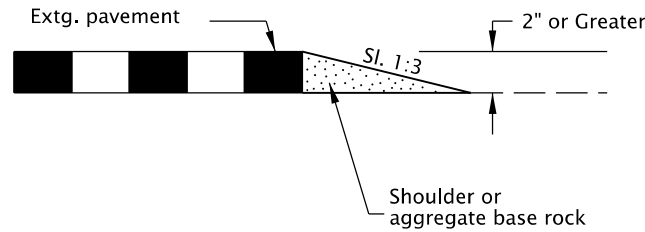

EXCAVATION ABRUPT EDGE

- NOTES:
- Install PCMS beyond the outside shoulder, when possible.
 - Use the appropriate type of barricade panels for PCMS location. Right shoulder, use Type B(III)R. Left shoulder, use Type B(III)L.
 - Use six drums in shoulder taper on 20' spacing. The drums and barricade may be omitted when PCMS is placed behind a roadside barrier.
 - Detail as shown is used for trailered and non-crashworthy components of:
 - Portable Traffic Signals
 - Smart Work Zone Systems

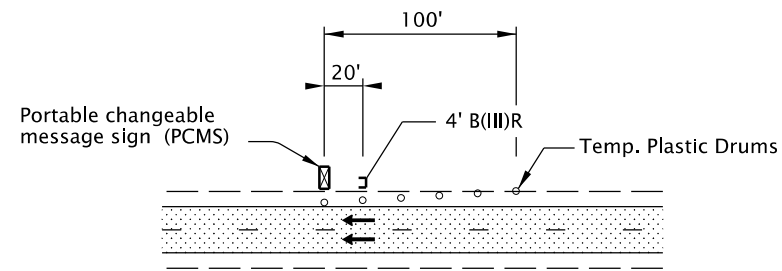

PORTABLE CHANGEABLE MESSAGE SIGN (PCMS) INSTALLATION

- NOTES:
- Install Flagger Station Lighting beyond the outside shoulder, where practical.
 - Use six tubular markers in shoulder taper on 10' spacing.
 - Place cart / generator / power supply off of the shoulder, as far as practical.

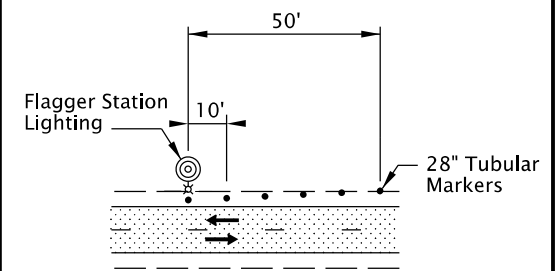

FLAGGER STATION LIGHTING DELINEATION

- NOTES:
- Abrupt edges may be created by paving, operations, excavations or other roadway work. Use abrupt edge signing for longitudinal abrupt edges of 1 inch or greater.
 - If the excavation is located on left side of traffic, replace the 8' B(III)R barricades with 8' B(III)L barricades and replace the "RIGHT" (CW21-8C) riders with "LEFT" (CW21-8A) riders.
 - Continue signing and other traffic control devices throughout excavation area at spacings shown.
 - If roll-up signs are used, attach the correct (CW21-9) plaques to the sign face using hook and loop fasteners. Place roll-up signs in advance of barricades.

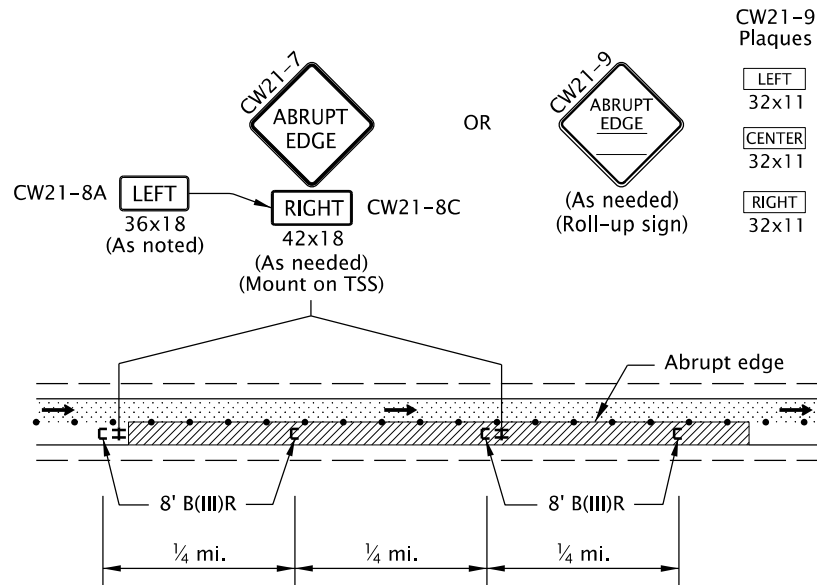

TYPICAL ABRUPT EDGE DELINEATION

- GENERAL NOTES FOR ALL TCP DRAWINGS:
- Signs and other Traffic Control Devices (TCD) shown are the minimum required.
 - Place a barricade approx. 20' ahead of all sequential arrow boards.
 - Arrows shown in roadway are directional arrows to indicate traffic movements.
 - All signs are 48" x 48" unless otherwise shown. Use fluorescent orange sheeting for the background of all temporary warning signs.
 - All diamond shaped warning signs mounted on barrier sign supports shall be 36" by 36". All other signs mounted on barrier sign supports shall not exceed 12 sq. ft. in total sign area.
 - Low speed highways have a pre-construction posted speed of 40 mph or less. High speed highways have a pre-construction posted speed of 45 mph or higher.
 - Do not locate sign supports in locations designated for bicycle or pedestrian traffic.
 - Combine drawing details to complete temporary traffic control for each work activity.
 - Coordinate and control pedestrian movements through a Temporary Accessible Route using Flaggers, Traffic Control Measures, or as directed.
 - To be accompanied by Dwg. Nos. TM820 & TM821.

The selection and use of this Standard Drawing, while designed in accordance with generally accepted engineering principles and practices, is the sole responsibility of the user and should not be used without first consulting a Registered Professional Engineer.

All materials shall be in accordance with the current Oregon Standard Specifications.			
OREGON STANDARD DRAWINGS			
TABLES, ABRUPT EDGE AND PCMS DETAILS			
2024			
DATE	REVISION DESCRIPTION		
07-2022	Added a note for TPARs		
CALC. BOOK NO.	N/A	SDR DATE	01-JUL-2022
			TM800

14-JUL-2023

TM821.dgn

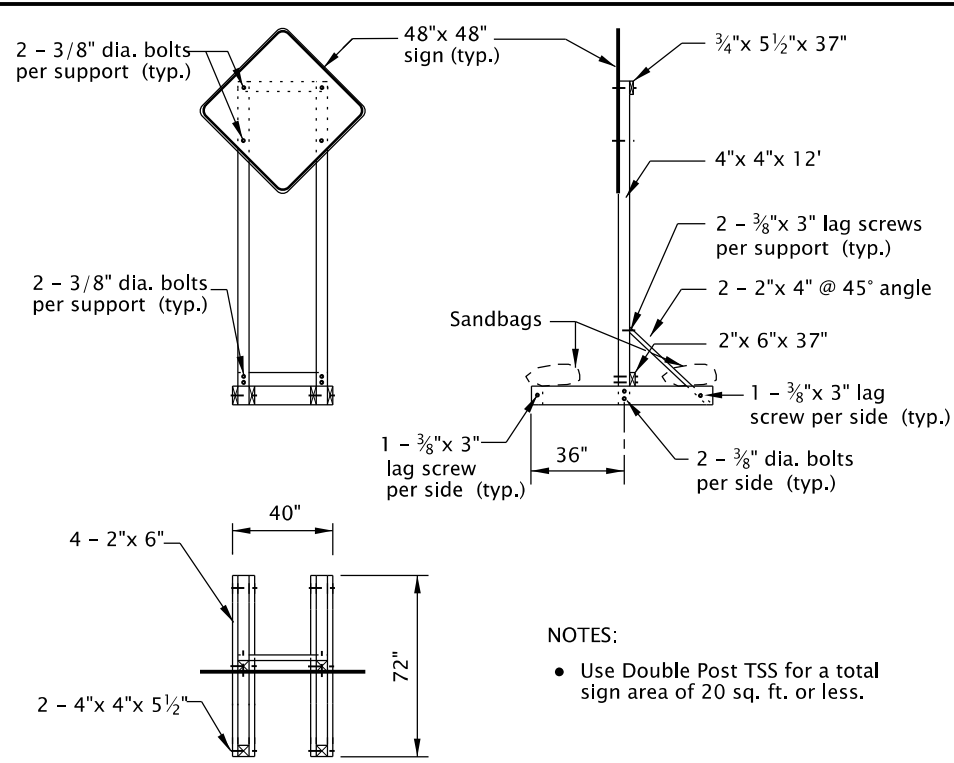

- NOTES:
- Use Double Post TSS for a total sign area of 20 sq. ft. or less.

DOUBLE POST DETAIL

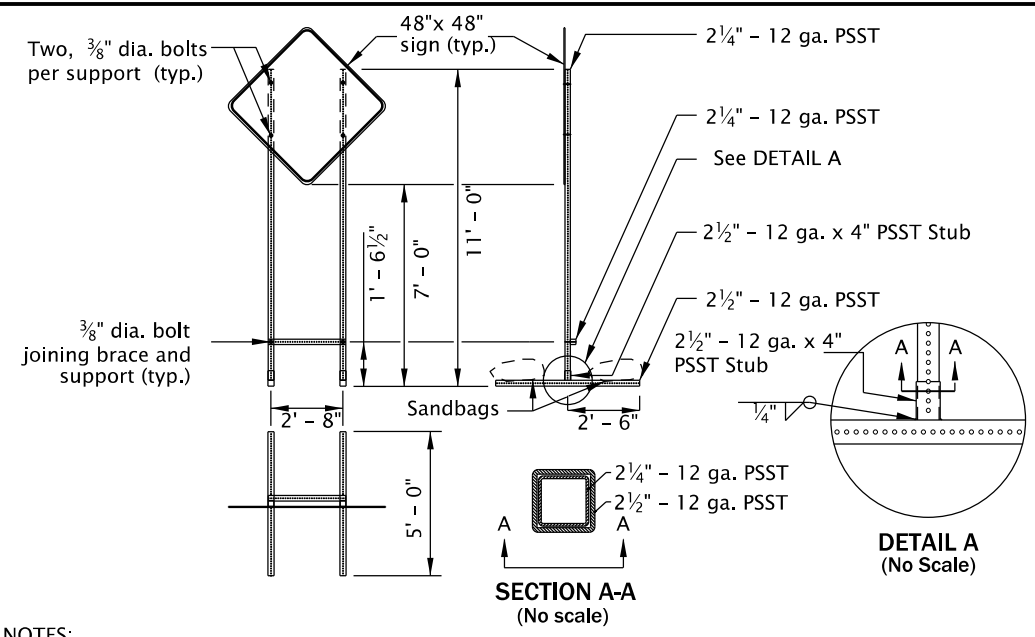

- NOTES:
- Use PSST TSS's for a total sign area of 16 sq. ft. or less.
 - All members shall have a minimum yield stress of 50 ksi.
 - Galvanize steel according to ASTM A653 with coating designation G90. Remove Galvanizing from steel before welding. Repair Galvanizing according to ASTM A780.
 - Use A325 Bolts or equivalent.
 - 2 1/4" - 12 ga. PSST to extend entire length inside of the 2 1/2" - 12 ga. x 4" PSST Stub.
 - Do not use bolt to secure 2 1/4" PSST inside of the 2 1/2" - 12 ga. x 4" PSST Stub.
 - Weld steel according to American Welding Society (AWS) D.1.1.

PERFORATED STEEL SQUARE TUBE (PSST) DETAIL

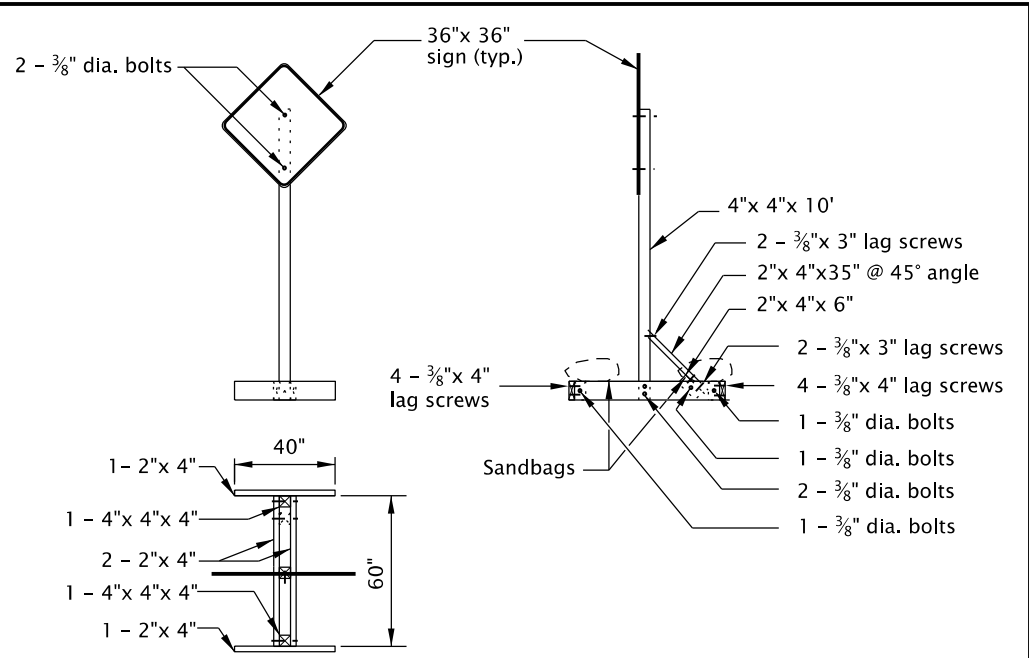

- NOTES:
- Use Single Post TSS for a total sign area of 12 sq. ft. or less.
 - Use Single Post TSS for mounting "Business Access" (CG20-11) signs. Do not mount signs on Type II or III Barricades.

SINGLE POST DETAIL

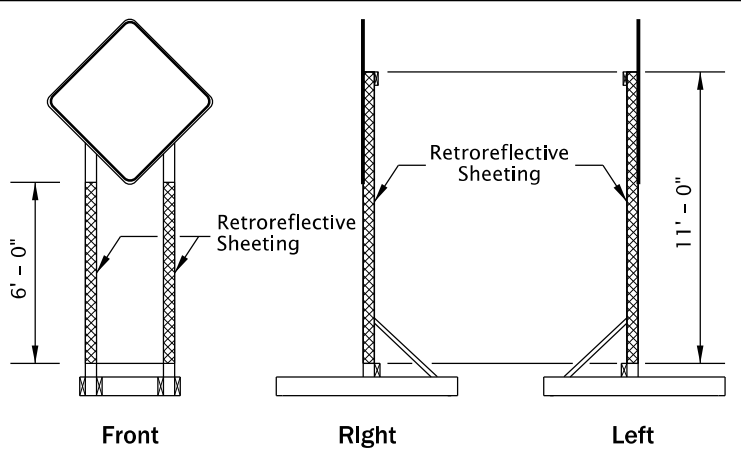

Double Post

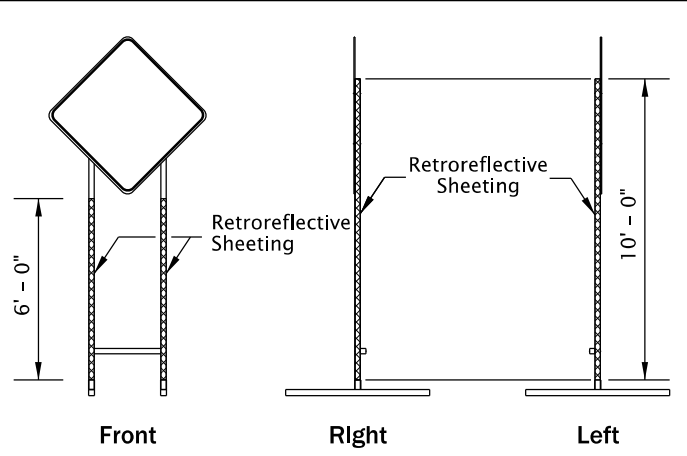

Perforated Steel Square Tube (PSST)

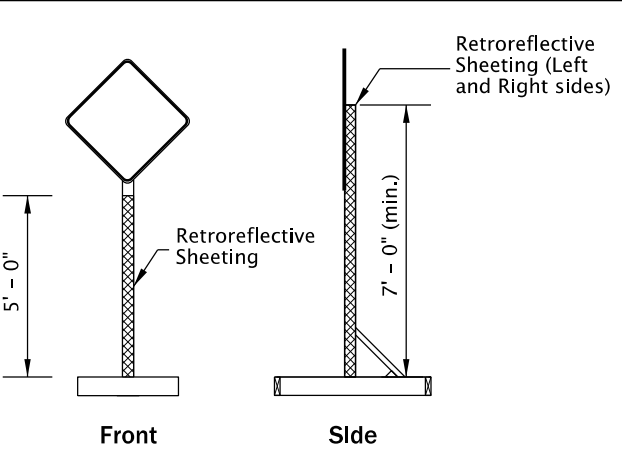

Single Post

Retroreflective Sheeting (Left and Right sides)

- TEMPORARY SIGN SUPPORT GENERAL NOTES:
- Do not tip over TSS at any time.
 - Do not locate TSS's in locations that block pedestrian or bicycle traffic.
 - For wooden TSS's, use either Douglas Fir or Hem Fir, which is surfaced four sides (S4S) and free of heart center (FOHC).
 - See "Temporary Sign Placement" detail on TM822 for sign installation heights.
 - Do not place or stack ballast more than 24" above the ground.
 - When not in use, locate TSS as far from Public Traffic as practicable and turn away from traffic, or cover the sign. Do not cover reflective sheeting on the TSS posts.
 - Place a minimum of 50 lbs of sandbags on each of the four TSS supports legs. (25 lb. max per bag) (min. 100 lbs per side of each TSS).
 - See Dwg. No. TM204 for flag board mounting detail.

- NOTES:
- Apply fluorescent orange, ANSI Type VIII or IX retroreflective sheeting to TSS posts, as shown, for all temporary signs, except "STOP" and "DO NOT ENTER". For "STOP" and "DO NOT ENTER" signs, used red ANSI Type III or IV retroreflective sheeting on the TSS posts.
 - Apply sign post retroreflectivity to each TSS post facing front; and to the left and right sides of the TSS, as shown. Use 3" wide sheeting for wood post TSS's. Use 2" wide sheeting for PSST TSS's.
 - Sheeting may be applied directly to post material; or applied to a rigid, lightweight substrate, then securely attached to the posts.

SIGN POST REFLECTIVE SHEETING PLACEMENT

The selection and use of this Standard Drawing, while designed in accordance with generally accepted engineering principles and practices, is the sole responsibility of the user and should not be used without first consulting a Registered Professional Engineer.

All materials shall be in accordance with the current Oregon Standard Specifications.

OREGON STANDARD DRAWINGS

TEMPORARY SIGN SUPPORTS

2024

DATE	REVISION	DESCRIPTION

CALC. BOOK NO. - - -	N/A - - -	SDR DATE - 14-JUL-2023 -	TM821
----------------------	-----------	--------------------------	--------------

Effective Date: December 1, 2023 – May 31, 2024

NOTES:

- Do not block bicycle lanes, sidewalks, or TPAR's with sign supports. Maintain minimum widths for these facilities according to TCP Design Manual, MUTCD, ADA, or as directed.
- To be accompanied by Dwg. Nos. TM670, TM671, TM687, TM688 & TM689.

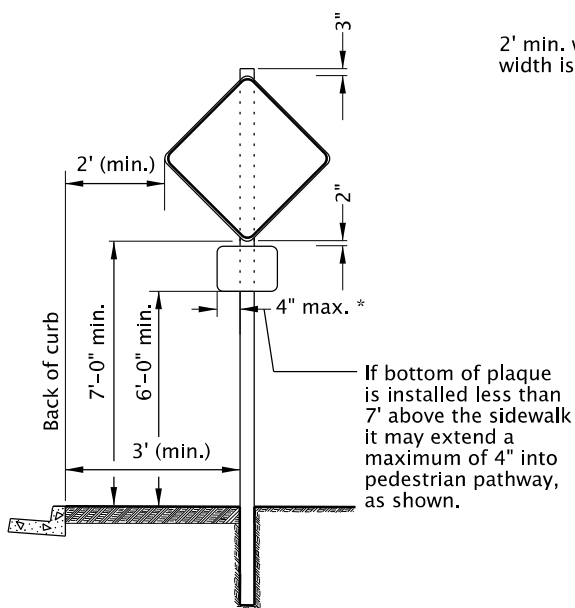

Urban Areas With Curb/Sidewalk

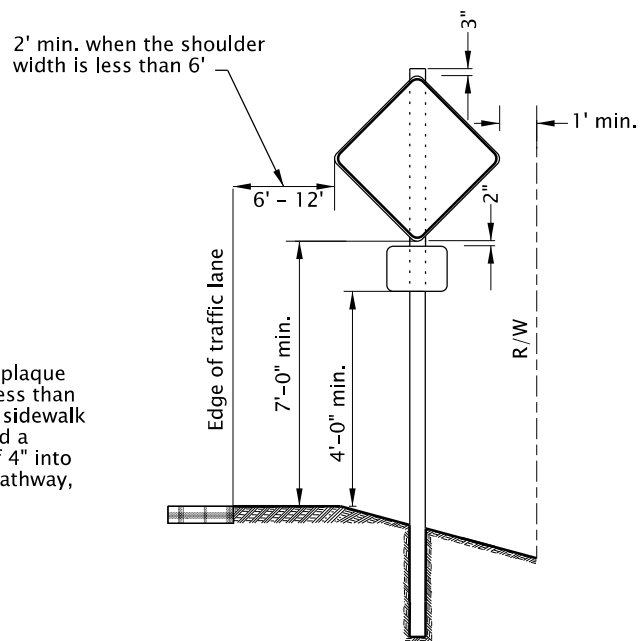

Rural Areas

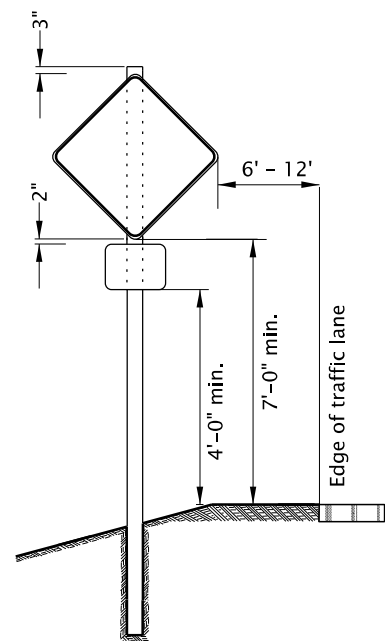

Divided Highway/Freeway Medians
No Curb/Sidewalk

Where temporary signs are located adjacent to or intrude into a paved shoulder or other surface used by bicycle traffic, install secondary sign (plaque) so bottom of sign is a minimum of 7'0" above pavement surface, as shown.

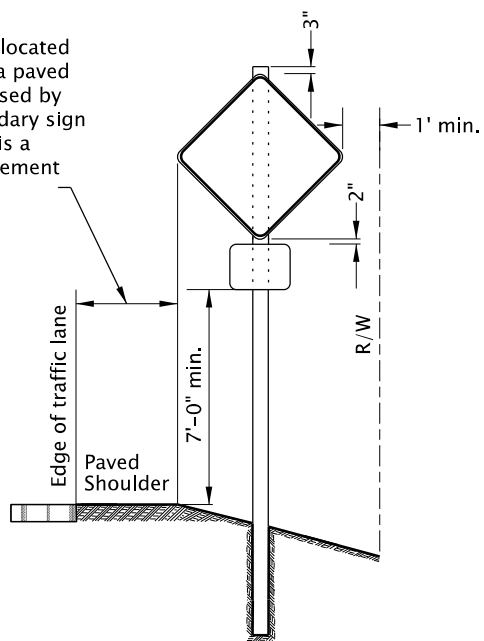

Rural or Urban Areas - Curb or No Curb
Bicycles On Shoulder

TEMPORARY SIGN PLACEMENT

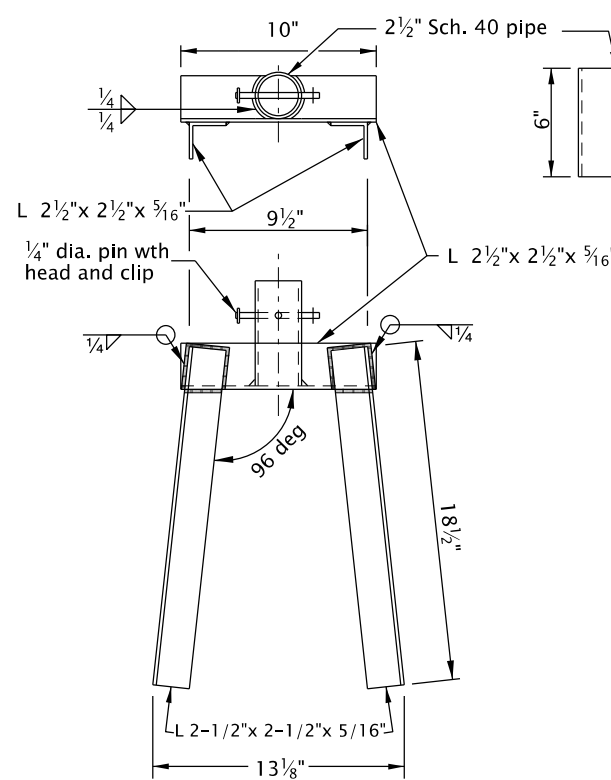

NOTES:

- Drill additional holes so sign can be rotated 90 degrees and pinned when not in use.
- All structural steel shall conform to ASTM A36.
- Support fits both 32" and 42" tall "F" barrier.
- Use for supporting a maximum 12 sq. ft. of total sign area.
- Place support at connection between two concrete barrier sections.
- Weld steel according to American Welding Society (AWS) D.1.1.
- Do not use clipped signs.
- Follow manufacturer recommendation when installing signs on barrier other than concrete.

CONCRETE BARRIER SIGN SUPPORT

The selection and use of this Standard Drawing, while designed in accordance with generally accepted engineering principles and practices, is the sole responsibility of the user and should not be used without first consulting a Registered Professional Engineer.

All materials shall be in accordance with the current Oregon Standard Specifications.

OREGON STANDARD DRAWINGS

TEMPORARY SIGN SUPPORTS

2024

DATE	REVISION	DESCRIPTION

CALC. BOOK NO. ---	N/A ---	SDR DATE 01-JUL-2020	TM822
--------------------	---------	----------------------	-------

01-JUL-2022

TM850.dgn

- NOTE:
- Continue "LOOSE GRAVEL" (CW8-7a) and "DO NOT PASS" (R4-1) signing throughout the area at spacing shown.
 - Use advisory speed "XX", 15 mph less than the pre-construction posted speed, or as directed. "XX MPH" placard shall not exceed a posted speed of 35 mph.

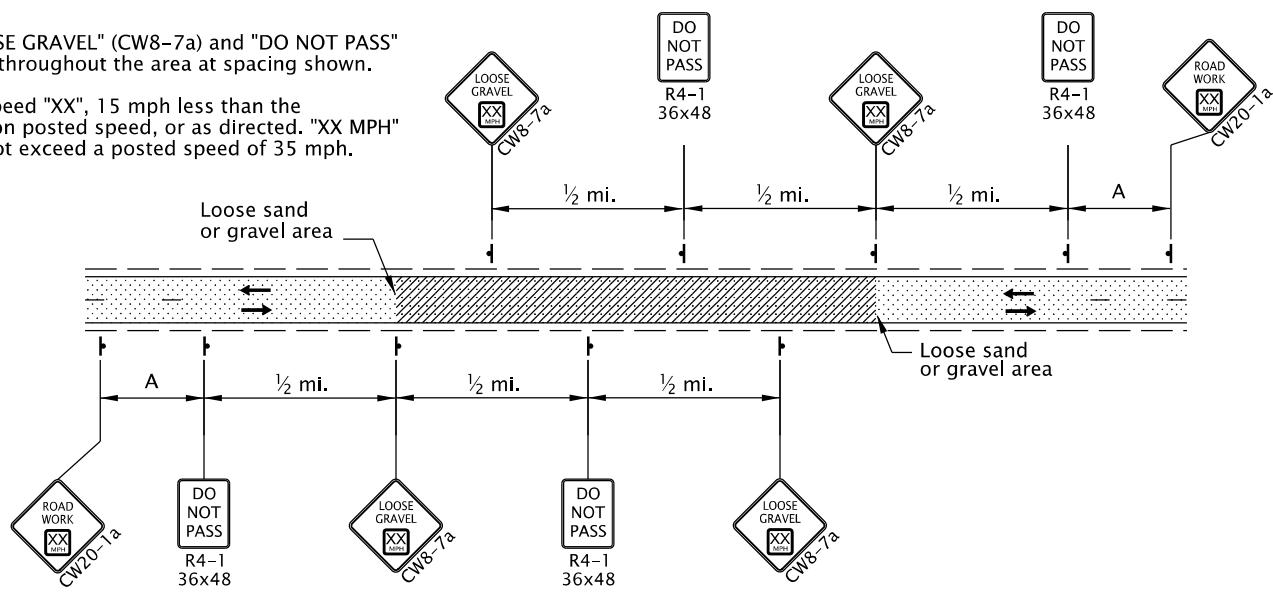

2-Lane, 2-Way Roadway
LOOSE GRAVEL IN ROADWAY SIGNING

- NOTE:
- Continue "ABRUPT EDGE" (CW21-(7,9)) and "DO NOT PASS" (R4-1) signing throughout the area at spacing shown.

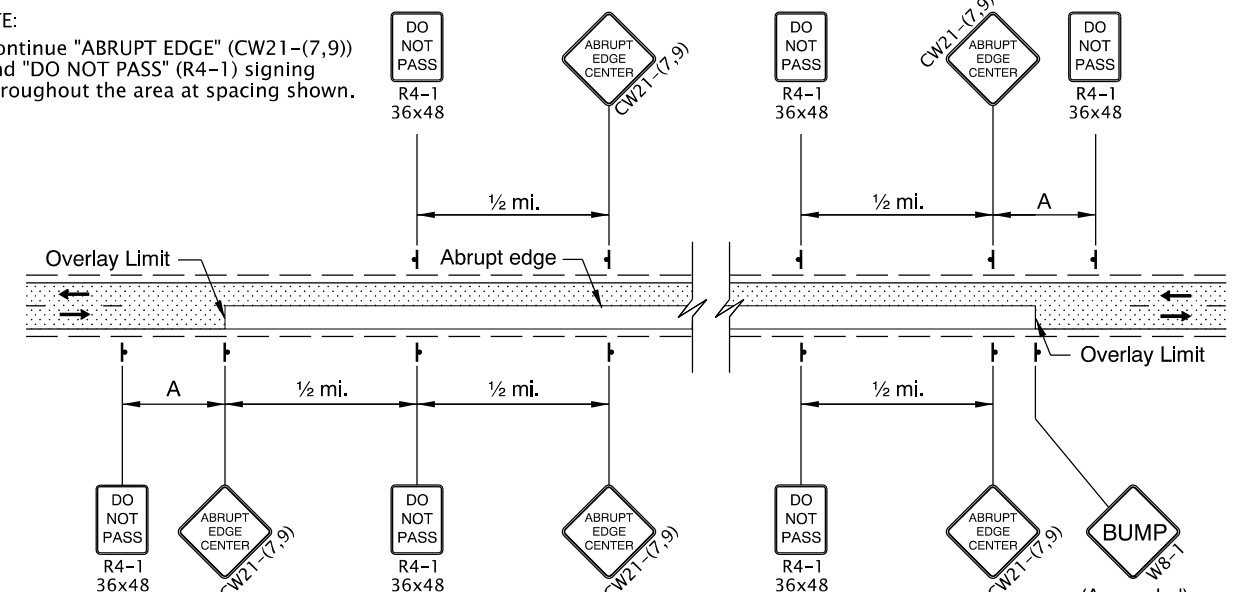

2-Lane, 2-Way Roadway
OVERLAY AREA SIGNING

- NOTES:
- Place Advance Flagger and additional signing when traffic queues extend beyond initial warning signing OR when sight distance is restricted.
 - Relocate initial "ROAD WORK AHEAD" (W20-1) sign in advance of additional "BE PREPARED TO STOP" (W3-4) and Flagger Ahead (CW23-2) signs, as shown.

- Place additional Tubular Markers for Flagger and Advance Flagger Stations according to FLAGGER STATION DELINEATION detail.

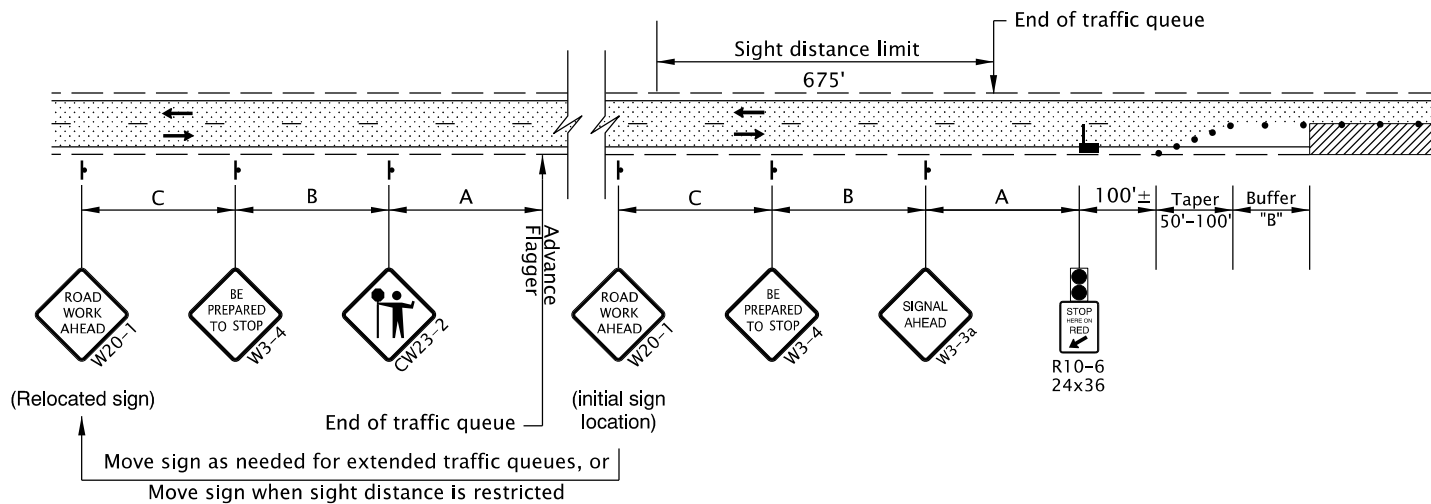

ADVANCE FLAGGER FOR EXTENDED TRAFFIC QUEUES

- NOTE:
- When using pilot cars with flaggers to control traffic during paving operations, the Tubular Marker spacing along centerline may be increased to 200' within the Activity Area, as shown or as directed.
 - Include "WAIT FOR FLAGGER" (CR4-23) signs mounted on Type II Barricade located approx. 50' before each Flagger.
 - Coordinate and control pedestrians movements through the TPAR using Flaggers, other TCM, or as directed. When the existing shoulder is greater than or equal to 4' wide, provide a minimum of 4' of width for the TPAR.

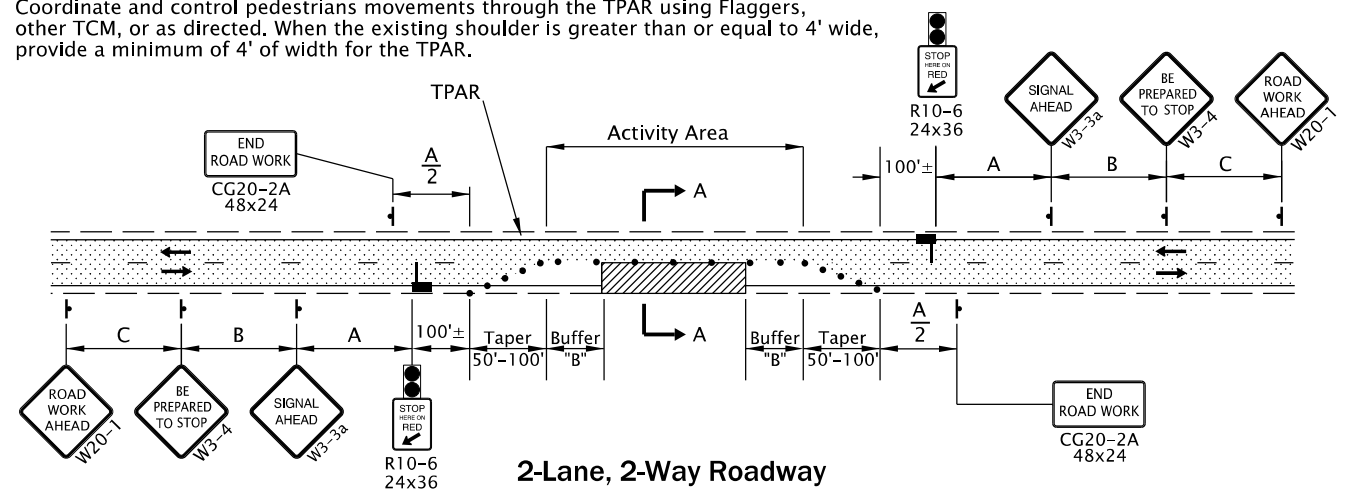
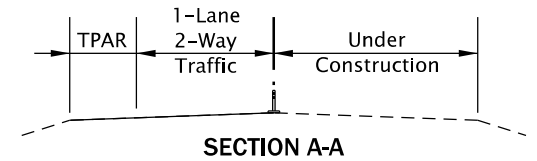

2-Lane, 2-Way Roadway
ONE LANE CLOSURE

GENERAL NOTES FOR ALL DETAILS:

- The "SIGNAL AHEAD" (W3-3a) sign may be substituted with the Signal Ahead (W3-3) symbol sign.
- Cover existing passing zone signing, as directed.
- Install temporary striping as required.
- To determine Taper Length ("L") and Buffer Length ("B"), use the "MINIMUM LENGTHS TABLE" shown on Dwg. No. TM800.
- To determine sign spacing A, B, and C, use "TRAFFIC CONTROL DEVICES (TCD) SPACING TABLE" on Dwg. No. TM800.
- Install a "BICYCLES ON ROADWAY" (CW11-1) sign in advance of the closure when a bike lane is closed, or when the shoulder is closed and bikes are expected.
- At night, flagger stations shall be illuminated according to the FLAGGER STATION LIGHTING DELINEATION detail on Dwg No. TM800.

- To be accompanied by Dwg. Nos. TM820, TM821 & TM854.

- Automated Flagging Assistance Device (AFAD)
- 28" Tubular Markers on 20' max. spacing for flagger tapers and stations
- 28" Tubular Markers See TCD Spacing Table on TM800 for max. spacing.
- UNDER TRAFFIC
- UNDER CONSTRUCTION
- CONSTRUCTION UNDER TRAFFIC

- NOTE:
- Use a minimum of 3 tubular markers in shoulder taper on 10' spacing for flagger station delineation.

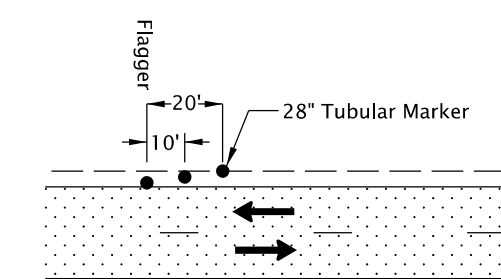

FLAGGER STATION DELINEATION

The selection and use of this Standard Drawing, while designed in accordance with generally accepted engineering principles and practices, is the sole responsibility of the user and should not be used without first consulting a Registered Professional Engineer.

All materials shall be in accordance with the current Oregon Standard Specifications.			
OREGON STANDARD DRAWINGS			
2-LANE, 2-WAY ROADWAYS			
2024			
DATE	REVISION DESCRIPTION		
01-2022	Added AFADs to drawing.		
CALC. BOOK NO.	N/A	SDR DATE	01-JUL-2022
			TM850

13-JAN-2023
TM855.dgn

NOTES:

- Place Advance Flagger and additional signing when traffic queues extend beyond initial warning signing OR when sight distance is restricted.
- Relocate initial "ROAD WORK AHEAD" (W20-1) sign in advance of additional "BE PREPARED TO STOP" (W3-4) and Flagger Ahead (CW23-2) signs, as shown.
- Place additional Tubular Markers for Flagger and Advance Flagger Stations according to FLAGGER STATION DELINEATION detail.

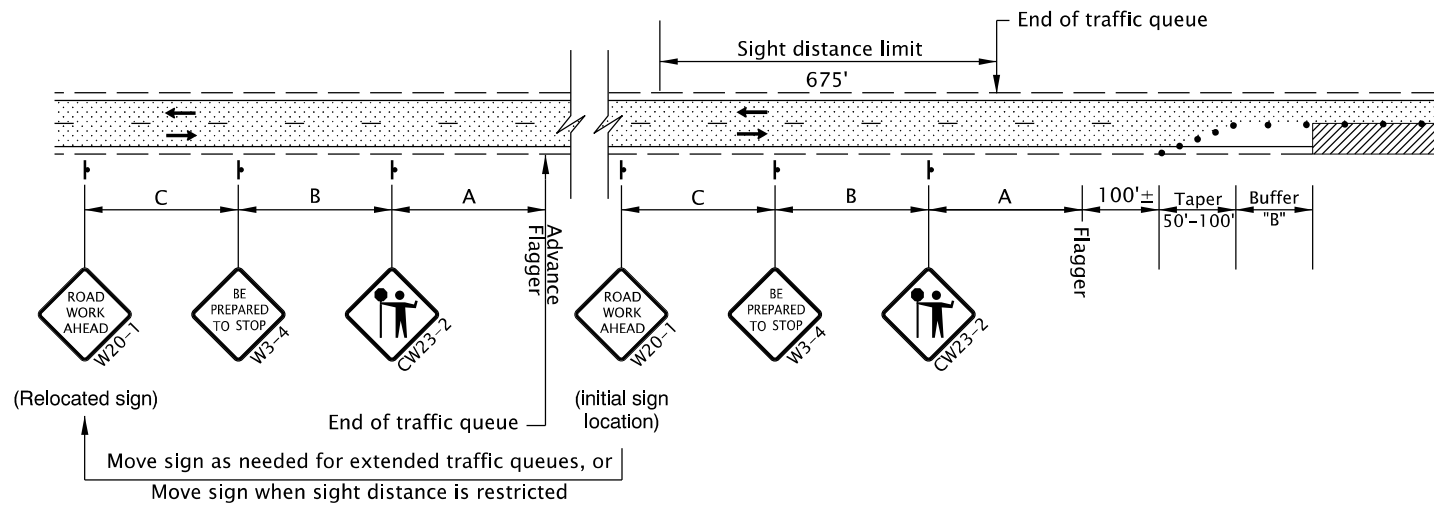

ADVANCE FLAGGER FOR EXTENDED TRAFFIC QUEUES

NOTE:

- When using pilot cars with flaggers to control traffic during paving operations, the Tubular Marker spacing along centerline may be increased to 200' within the Activity Area, as shown or as directed.
- Include "WAIT FOR FLAGGER" (CR4-23) signs mounted on Type II Barricade located approx. 50' before each Flagger.
- Coordinate and control pedestrians movements through the TPAR using Flaggers, other TCM, or as directed. When the existing shoulder is greater than or equal to 4' wide, provide a minimum of 4' of width for the TPAR.

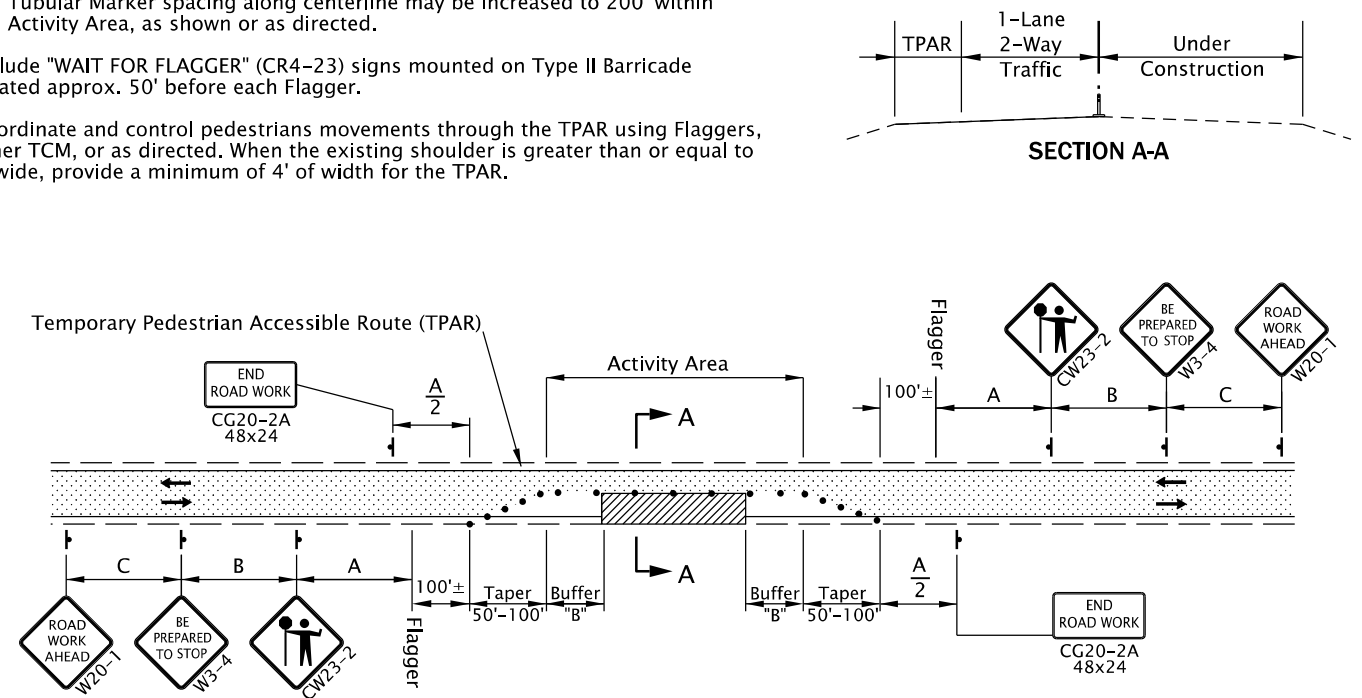

**2-Lane, 2-Way Roadway
ONE LANE CLOSURE**

GENERAL NOTES FOR ALL DETAILS:

- This drawing is only intended to be used where an Automated Flagger Assistance Device (AFAD) cannot be utilized.
- The "FLAGGER" (CW23-2) symbol sign shall be used only in conjunction with the "BE PREPARED TO STOP" (W3-4) sign.
- Cover existing passing zone signing, as directed.
- Install temporary striping as required.
- To determine Taper Length ("L") and Buffer Length ("B"), use the "MINIMUM LENGTHS TABLE" shown on Dwg. No. TM800.
- To determine sign spacing A, B, and C, use "TRAFFIC CONTROL DEVICES (TCD) SPACING TABLE" on Dwg. No. TM800.
- Install a "BICYCLES ON ROADWAY" (CW11-1) sign in advance of the closure when a bike lane is closed, or when the shoulder is closed and bikes are expected.
- At night, flagger stations shall be illuminated according to the FLAGGER STATION LIGHTING DELINEATION detail on Dwg No. TM800.
- To be accompanied by Dwg. Nos. TM820 & TM821.

- 28" Tubular Markers on 10' max. spacing around intersection radii.
- 28" Tubular Markers on 20' max. spacing for flagger tapers and stations
- 28" Tubular Markers See TCD Spacing Table on TM800 for max. spacing.

..... UNDER TRAFFIC
 // UNDER CONSTRUCTION

NOTE:

- Additional Traffic Control Measures (TCM) may be required for all legs of the intersection

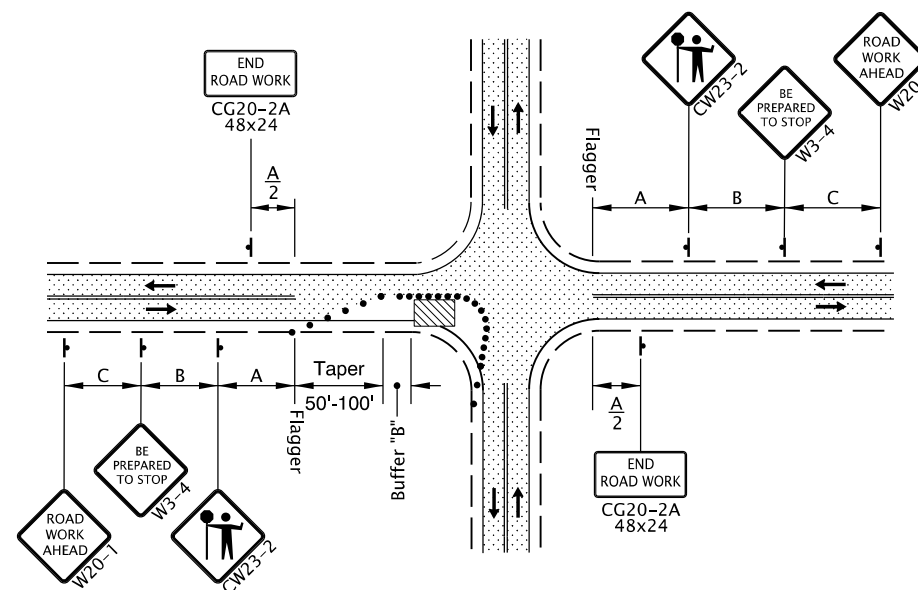

**2-Lane, 2-Way Roadway
ONE LANE CLOSURE, INTERSECTION**

NOTE:

- Use a minimum of 3 tubular markers in shoulder taper on 10' spacing for flagger station delineation.

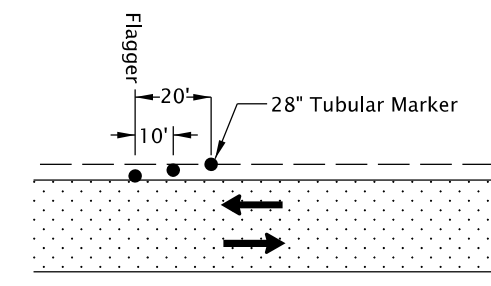

FLAGGER STATION DELINEATION

The selection and use of this Standard Drawing, while designed in accordance with generally accepted engineering principles and practices, is the sole responsibility of the user and should not be used without first consulting a Registered Professional Engineer.

All materials shall be in accordance with the current Oregon Standard Specifications.			
OREGON STANDARD DRAWINGS			
2-LANE, 2-WAY ROADWAYS			
2024			
DATE	REVISION DESCRIPTION		
CALC. BOOK NO.	N/A	SDR DATE	13-JAN-2023
			TM855