

BIDDING DOCUMENTS

PROJECT: PAVING OF OLD BEND-REDMOND HWY:
US 20 TO TUMALO RD

PROJECT #: W66139

BID OPENING: JULY 26, 2023

COMPLETION DATE: OCTOBER 13, 2023

CONTRACTING AGENCY:



**ROAD
DEPARTMENT**

**61150 SE 27TH STREET
BEND, OREGON 97702
PHONE: (541) 388-6581
FAX: (541) 388-2719
WEB: www.deschutescounty.gov/road**



ROAD DEPARTMENT

BIDDING DOCUMENTS

PAVING OF OLD BEND-REDMOND HWY: US 20 TO TUMALO RD

TABLE OF CONTENTS

INVITATION TO BID.....A1

INFORMATION FOR BIDDERS.....A2

BID PROPOSAL FORM.....B1

SCHEDULE OF BID ITEMS.....B4

SUBCONTRACTOR DISCLOSURE FORM.....B5

BID GUARANTY FORM.....B6

CONTRACT AGREEMENT FORM (FOR INFORMATION ONLY).....C1

PERFORMANCE BOND FORM (FOR INFORMATION ONLY).....C3

PAYMENT BOND FORM (FOR INFORMATION ONLY).....C5

SPECIAL PROVISIONS.....SP1

PROJECT PLANS

DESCRIPTION OF PARTS OF BIDDING DOCUMENTS WHICH ARE NOT BOUND HEREIN:

OREGON STANDARD SPECIFICATIONS FOR CONSTRUCTION, 2021

The Specification that is applicable to the Work on this Project is the 2021 edition of the "Oregon Standard Specifications for Construction". All number references in these Special Provisions shall be understood to refer to the Sections and subsections of the Standard Specifications bearing like numbers and to Sections and subsections contained in these Special Provisions in their entirety.

**DESCHUTES COUNTY, OREGON
ROAD DEPARTMENT**

**INVITATION TO BID
PAVING OF OLD BEND-REDMOND HWY: US 20 TO TUMALO RD**

Sealed bids will be received at the Deschutes County Road Department, 61150 SE 27th Street, Bend, Oregon 97702, until but not after, **2:00 p.m. on July 26, 2023**, at which time and place all bids for the above-entitled public works project will be publicly opened and read aloud.

The Class of Work of this Project is Asphalt Concrete Paving and Oiling. The value for this Contract is estimated to be between \$1,000,000 and \$1,350,000. The Work will consist of, but not be limited to, the following:

- Install and maintain temporary traffic control.
- Perform cold plane pavement removal.
- Construct asphalt concrete pavement.
- Install permanent pavement markings and delineation.
- Perform additional and incidental work as called for by the specifications and plans.

Specifications and other bid documents may be inspected and obtained from the Deschutes County Bids and RFPs website at <https://www.deschutescounty.gov/rfps>. Inquiries pertaining to these specifications shall be directed to Blaine Wruck, Transportation Engineer, in writing at Blaine.Wruck@deschutescounty.gov or the address above.

Bids shall be made on the forms furnished by the County, including a Bid Bond or Cashiers Check for the minimum amount of 10% of the Bid Price, addressed and mailed or delivered to Chris Doty, Department Director, 61150 SE 27th Street, Bend, Oregon 97702 in a sealed envelope plainly marked "BID FOR PAVING OF OLD BEND-REDMOND HWY: US 20 TO TUMALO RD" and the name and address of the bidder.

Bidders must submit a Subcontractor Disclosure Statement. The subcontractor disclosure statement may be submitted in the sealed bid prior to 2:00 p.m. on July 26, 2023 or in a separate sealed envelope marked "SUBCONTRACTOR DISCLOSURE STATEMENT - PAVING OF OLD BEND-REDMOND HWY: US 20 TO TUMALO RD" prior to 4:00 p.m. on July 26, 2023 at the above location.

Because the work called for under this contract is for a public works project subject to state prevailing rates of wage under ORS 279C.800 to 279C.870, the County will not receive or consider a bid unless the bid contains a statement by the bidder that the bidder will comply with ORS 279C.838 and ORS 279C.840. Each bid must contain a statement as to whether the bidder is a resident bidder, as defined in ORS 279A.120. Vendors shall use recyclable and/or sustainably sourced products to the maximum extent economically feasible in the performance of the contract work set forth in this document.

Bidders shall be prequalified with the State of Oregon for the Class of Work stated above in accordance with ORS 279C.430 through 279C.450 and Deschutes County Code 12.52.020. The successful bidders and subcontractors providing labor shall maintain a qualified drug testing program for the duration of the contract. Bidders shall be licensed with the Construction Contractor's Board. Contractors and subcontractors need not be licensed under ORS 468A.720.

Deschutes County may reject any bid not in compliance with all prescribed bidding procedures and requirements, and may reject for good cause any or all bids upon a finding of Deschutes County it is in the public interest to do so. The protest period for this procurement is seven (7) calendar days.

CHRIS DOTY
Road Department Director

PUBLISHED:
DAILY JOURNAL OF COMMERCE: July 12, 2023
THE BEND BULLETIN: July 12, 2023

INFORMATION FOR BIDDERS

1. **General Description of Project.** A general description of the Work to be performed is contained in the Invitation to Bid. The scope is indicated in the applicable parts of these Solicitation Documents.
2. **Solicitation Documents.** The Solicitation Documents under which it is proposed to execute the Work consist of the material bound herewith. These solicitation documents are intended to be mutually complementary and to provide all details reasonably required for the execution of the proposed work.
3. **Form of Proposals.** All proposals must be submitted on the forms furnished. Subcontractor disclosure form may be submitted with the bid or in a separate envelope.
4. **Substitutions.** Materials and/or products called for in the specifications are named in order to establish a standard of quality design. Manufacturers or suppliers of products similar to those specified may submit bids on the work providing requests for approval of substitution materials are made at least seven (7) calendar days prior to the bid opening. Adequate information on which to base approval or disapproval must be furnished to the Road Department Director or his representative and the Road Department Director shall be the sole judge of any request. When the Road Department Director approves a substitution, it is with the understanding that the Contractor guarantees the substituted article or materials to be equal or better than the specified.
5. **Preparation of Proposals.** All blank spaces in the proposal form must be filled in, in ink, or typed, in both words and figures where required. No changes shall be made in phraseology of the forms. Written amount shall govern in cases of discrepancy between the amount stated in writing and amount stated in figures.

Any proposal shall be deemed informal which contains omissions, erasures, alterations, or additions of any kind, or prices uncalled for, or which, in any manner shall fail to conform to the conditions of the published invitation to bidders.

The bidder shall sign his/her proposal in the blank space provided therefore. Proposals made by corporations or partnerships shall contain names and addresses of the principal officers or partners therein. If a corporation makes a proposal, it must be signed by one of the principal officers thereof, and the corporate seal affixed.

If made by a partnership, it must be signed by one of the partners, clearly indicating that he is signing as a partner of the firm. In the case of a proposal made by a joint venture, each of the joint venturers must sign the proposal in his personal capacity.

The wording of the proposal shall not be changed. Any additions, conditions, limitations or provisions inserted by the bidder will render the proposal irregular and may cause its rejection.

6. **Submission of Proposals.** All proposals must be submitted in the time and place and in the manner prescribed in the invitation to bid. Proposals must be made on the prescribed proposal forms furnished. Each proposal must be submitted in a sealed envelope, so marked as to indicate its contents without being opened. If the proposal is submitted by mail, the sealed envelope containing the bid must be enclosed in a separate envelope plainly addressed for mailing to conformance with instructions in the Invitation to Bid.

A responsive bid proposal must include the following completed items:

- Bid Proposal Form
- Schedule of Bid Items
- Bid Guaranty Form

7. **Modification or Withdrawal of Proposal.** Any bidder may modify his bid by written or telegraphic communication at any time prior to the scheduled closing time for receipt of bids, provided such communication is received by the County prior to the closing time, and provided further that a written confirmation of a telegraphic modification over the signature of the bidder was mailed prior to the closing time. If written confirmation of a telegraphic communication is not received within at least two calendar days of the closing time, no consideration will be given to the modification. The written or telegraphic communication should not reveal the bid price, but should state the addition or subtraction or other modification so that the County will not know the final prices or terms until the sealed bid is opened.

Proposals may be withdrawn prior to the scheduled time for the opening of the proposals either by telegraphic or written request, or in person. No proposal may be withdrawn after the time scheduled for opening of proposals, unless the County has failed to comply with the time limits applicable to award of the Contract.

8. **Disclosure of First Tier Subcontractors.** Bidders are required to disclose information about certain first-tier subcontractors (see ORS 279C.370). Specifically, when the contract amount of a first-tier subcontractor furnishing labor or labor and materials would be greater than or equal to: (i) 5% of the project Bid, but at least \$15,000; or (ii) \$350,000 regardless of the percentage, the Bidder must disclose the following information about that subcontract either in its Bid submission, or within two hours after Bid Closing:

(A) The subcontractor's name;

(B) The category of Work that the subcontractor would be performing, and

(C) The dollar value of the subcontract.

If the Bidder will not be using any subcontractors that are subject to the above disclosure requirements, the Bidder is required to indicate "NONE" on the accompanying form.

THE CONTRACTING AGENCY MUST REJECT A BID IF THE BIDDER FAILS TO SUBMIT THE DISCLOSURE FORM WITH THIS INFORMATION BY THE STATED DEADLINE (see OAR 137-049-0360).

A Bidder shall submit the disclosure form either in its Bid submission or within two working hours after Bid Closing in the manner specified by the Invitation to Bid.

Compliance with the disclosure and submittal requirements of ORS 279C.370 and OAR 137-049-0360 is a matter of Responsiveness. Bids that are submitted by Bid Closing, but for which the disclosure submittal has not been made by the specified deadline, are not Responsive and shall not be considered for Contract Award.

Substitution of affected first-tier subcontractors shall be made only in accordance with ORS 279C.585.

9. **Bid Security.** The Bid Bond or Cashier's Check will be for a minimum of ten per cent (10%) of the amount of the bid price. If a bidder bids more than one bid proposal, each proposal must be accompanied by separate bid security. The County reserves the right to retain the bid security of the three (3) lowest bidders until the successful bidder has signed and delivered the contract and furnished one hundred percent (100%) Performance and Payment Bonds.
10. **Conditions of Work.** Each bidder must inform himself of the conditions relating to the execution of the work, and make himself thoroughly familiar with all the Contract documents. Failure to do so will not relieve the successful bidder of his obligations to enter into a Contract and complete the contemplated work in strict accordance with the Contract documents. Each bidder must inform himself on all laws and statutes, both Federal and State, relative to the regular execution of the work, the employment of labor, protection of public health, access to the work and similar requirements.
11. **Award of Contract.** The award of the contract will be made by the County on the basis of the proposal which in its sole and absolute judgment will best serve the interest of the County.

County will issue a notice of intent to award contract. Any bidder may protest the notice of intent to award contract within seven (7) calendar days of the notice of intent to award contract.

The County reserves the right to accept or reject any or all proposals, and to waive any informalities and irregularities in said proposals.

12. **Payment and Retainage.** Payment for work performed will be made by the County as specified in the Special Provisions based upon the contract unit prices on the Bid Schedule.

Upon substantial completion of the contract, Contractor may request a partial release of retainage held by the County. The maximum amount of a request for a partial release retainage shall be the Contract amount less 150 percent of the estimated cost of the Contract yet to be performed through final completion. Upon final completion, Contractor may request release of the remaining retainage. Each request for the release of retainage shall be accompanied by the Consent of the contractor's surety.

13. **Performance Bond and Payment Bond.** The successful bidder shall file with the County, at the time of execution of the contract, a Performance Bond and a Payment Bond each of not less than the contract price on the forms furnished by the County. The Surety Company furnishing the required bonds shall have a sound financial standing and a record of service satisfactory to the County, and shall be authorized to do business in the State of Oregon. In lieu of a Performance Bond, the contractor may file cash, a Certified or Cashier's Check made payable to Deschutes County, Oregon. This money, check or certificate will be held by the County conditioned on and subject to the same provisions as set forth in the attached Performance Bond. ORS 279C.380 allows no flexibility for a cash deposit in lieu of a Payment Bond.
14. **Required Public Works Bond.** Before starting work on this project the Contractor and every subcontractor to which Contractor is a party for the performance of work under this contract must have a public works bond filed with the Construction Contractors Board, 700 Summer St. NE, Suite 300, Salem, Oregon 97309-5052, before starting work on the project, unless exempt under section 2 (7) or (8) of 2005 Oregon Laws Chapter 360 ORS 279C.836(7) or (8). Every subcontract to which Contractor is a party for the performance of work under this contract shall contain a provision requiring the subcontractor to have a public works bond filed with the Construction Contractors Board before starting work on this project, unless exempt under ORS 279C.836 (7) or (8) section 2 (7) or (8) of 2005 Oregon Laws Chapter 360.
15. **Failure to Execute Contract.** Upon failure by the successful bidder to enter into the Contract and furnish the necessary bond within fifteen (15) calendar days from the date the Contract documents are sent or otherwise conveyed to the Bidder, the bid bond accompanying the bid shall be forfeited, the proceeds paid to the County, and the award withdrawn. The award may then be made to the next lowest responsible bidder, or all bids rejected and the work is re-advertised.
16. **Disclaimer of Responsibility.** Neither the County nor the Road Department Director will be responsible for oral interpretations. Should a bidder find discrepancies in, or omissions from the drawings, specifications, or other pre-bid documents, or be in doubt as to their meaning, he shall notify the County at least seven (7) calendar working days prior to the bid opening date. Any and all such interpretations, any supplemental instructions or approval of manufacturer's materials to be substituted will be made only in the form of written addenda to the specifications, which, if issued, will be hand delivered or sent by regular mail, email and fax to all prospective bidders receiving a set of such documents, not later than two (2) calendar days prior to the date fixed for the opening of bids. Failure of any bidder to receive any such addendum or interpretation shall not relieve such bidder from any obligation under his bid as submitted. All addenda so issued are to be covered in the bid for such addenda to become part of the Agreement.
17. **Permits and Licenses.** The successful bidder shall be required to have or obtain, at his expense, any and all permits and licenses required by Deschutes County, any City within the County, and the State of Oregon, pertaining to the service he proposes to furnish. Licensing shall include

without limitation registration with Construction Contractors Board and in the case of professional engineers and architects proof of current licensing with the appropriate State licensing board.

18. **Minimum Requirements of Bid.** The following minimum requirements as to the form and manner of submitting bids must be strictly observed; variance from these requirements will result in rejection of the bid as unresponsive.
- a. Each Bid must be submitted on forms furnished by the County. The completed forms required for a bid to be considered responsive, which are included herein, are listed below:
 - Bid Proposal Form
 - Schedule of Bid Items
 - First-Tier Subcontractor Disclosure Form
 - Bid Bond
 - Signed Addenda (if issued)
 - b. Each Bid must be signed by the bidder.
 - c. Bid security, in the required form and amount, must accompany each bid.
 - d. Each blank in the proposal must be filled in unless an alternative is provided. Each separate bid item must be bid on, unless the proposal form clearly indicates otherwise.
 - e. Each Bid must be submitted in a separate sealed envelope, marked to identify without opening, and in the hands of the Road Department Director at the time and place specified for bid opening.
 - f. A proposal containing modifications, deletions, exceptions or reservations which in any way conflict with or purport to alter any substantive provision contained in the bid documents, will not be considered.
 - g. A conditional bid will not be considered.
 - h. Any bid submitted without all of the pages of the bid documents shall be deemed to have been submitted with the missing pages for purposes of bid evaluation if, at a minimum, the completed pages identified above in (a) are included in the submission. The missing pages of the bid documents shall be deemed to be incorporated into bid by reference.
19. **Plans.** Plans are not to be taken or construed as being reproduced at precisely the indicated scale. Where the plans are photographic reductions of the original tracings, the approximate amount of reduction is indicated by a note on the plans.
20. **Specifications.** The specifications are the minimum acceptable specifications for the project for which proposals are sought. Any deviation

from the specifications contained herein, shall render the bid non-responsive.

21. **Examination of Site and Conditions.** Bidders are required, prior to submission of bids, to carefully examine the site and the Plans and Specifications of the contemplated work. Errors and omissions in the Plans or Specifications shall be called to the attention of the Agency prior to submission of bid so that addenda may be issued. Failure to do so on the part of the Contractor does not relieve him of responsibility for a correct and completely finished job. Only a written interpretation or correction by addendum shall be binding.
22. **Pre-Bid Inquiries.** Bidders with pre-bid inquiries shall contact Blaine Wruck, Transportation Engineer, in writing at:

Email: blaine.wruck@deschutescounty.gov; or

Mailing Address: 61150 SE 27th Street, Bend, Oregon 97702.

Contracting Agency will not mail notice of Addenda, but will publish notice of any Addenda on Contracting Agency's Web site. Addenda may be downloaded off the Contracting Agency's Web site. Bidders should frequently check the Contracting Agency's Web site until closing, i.e., at least once weekly until the week of Closing and at least once daily the week of the Closing.

23. **Prequalification of Bidders.** Bidders shall be pre-qualified with the State of Oregon in accordance with ORS 279C.430 and Deschutes County Code 12.52.020. The prequalification class is as shown in the Invitation to Bid. Bidders shall be prequalified in the appropriate class of work at the time of bid opening. Bidders shall be licensed with the Construction Contractor's Board under OAR 137-049-0230. Contractors and subcontractors need not be licensed under ORS 468.710.
24. **Contract Award.** Deschutes County reserves the right to postpone award of the contract for fourteen (14) calendar days from the date of the bid opening, or until a final decision is made on a protest, whichever is later.
25. **Bidder Statement.** This Contract is subject to ORS 279C.800 to ORS 279C.870. Submission of a bid for the project shall constitute a statement that the bidder agrees to be bound by and will comply with provisions of 279C.838, 279C.840 or 40 U.S.C. 3141 to 3148. The successful bidder and subcontractors providing labor shall maintain a qualified drug-testing program for the duration of the Contract.

By submitting a bid for the project, the bidder certifies that the bidder has not discriminated and will not discriminate against any disadvantaged business enterprise, minority-owned business, women-owned business, emerging small business, or business that a service-disabled veteran owns, in obtaining any required subcontracts. Failure to do so shall be grounds for disqualification.

BID PROPOSAL FORM

PAVING OF OLD BEND-REDMOND HWY: US 20 TO TUMALO RD

BIDDER NAME

CCB#

ADDRESS

CITY

STATE

ZIP CODE

CONTACT NAME

CONTACT PHONE NUMBER

CONTACT EMAIL ADDRESS

The undersigned, hereinafter called the Bidder, declares that the only persons or parties interested in this Proposal are those named herein; that this Proposal is, in all respects, fair and without fraud; and it is made without collusion with any official of Deschutes County, Oregon, hereinafter called County; and that the Proposal is made without any connection or collusion with any person making another proposal on this contract.

The Bidder further declares that Bidder has carefully examined the contract documents; that Bidder is satisfied as to the quantities involved, including materials and equipment, and conditions of work involved; and that this proposal is made according to the provisions and under the terms of the contract documents, which documents are hereby made a part of this Proposal.

The Bidder agrees that all of the applicable provisions of Oregon law relating to public contracts (ORS Chapter 279) are, by this reference, incorporated in and made a part of this Proposal.

The Bidder declares that (check appropriate box):

Bidder is a resident bidder of the State of Oregon.

Bidder is a nonresident bidder from the State of _____.

The Bidder declares that Bidder is not in violation of any tax laws of the State of Oregon and Deschutes County, including but not limited to those programs listed in ORS 305.380(4),

The Bidder further agrees that if this Proposal is accepted, Bidder will, within fifteen (15) calendar days after conveyance of the contract documents to the Bidder, execute the contract with the County in the form of contract annexed hereto; and will, at the time of execution of the contract, deliver to the County the Performance and Payment Bonds (See Section 13 Information for Bidders) required herein; and will, to the extent of this Proposal, furnish all materials necessary to complete the work in the manner, in the time, and according to the methods as specified in the contract documents and required by the Road Department Director.

The Bidder certifies that it has a drug testing program in place for its employees, or warrants that a drug testing program will be in place prior to execution of this contract, that the drug testing program is in writing, that new employees must pass a drug screening, that existing employees may be tested for reasonable cause or when an employee is injured or involved in an accident resulting in property

damage. The Bidder agrees that each subcontractor providing labor under this Contract shall maintain a qualifying drug testing program for the duration of the Contract.

The Bidder agrees to comply with the provisions of 279C.838, 279C.840 or 40 U.S.C. 3141 to 3148 ORS 279C.840.

The Bidder certifies that the Bidder has not discriminated and will not discriminate against any disadvantaged business enterprise, minority-owned business, women-owned business, emerging small business, or business that a service-disabled veteran owns, in obtaining any required subcontracts in accordance with ORS 279A.110(4).

The Bidder agrees to commence work upon the issuance of a "Notice to Proceed" by the County and fully complete the project according to the time schedule specially set forth in the contract documents.

The Bidder further agrees to pay liquidated damages for failure to complete within the specified time.

It is agreed that if the Bidder is awarded the contract for the work herein proposed and shall fail or refuse to execute the contract and furnish the contract and furnish the specified Performance and Payment Bond within fifteen (15) calendar days after the contract documents are sent or otherwise conveyed to the Bidder, then, in that event, the bid security deposited herewith according to the conditions of the Invitation to Bid and Information for Bidders shall be retained by the County as liquidated damages; and it is agreed that the said sum is a fair measure of the amount of damage the County will sustain in case the Bidder shall fail or refuse to enter into the contract for the said work and to furnish the Performance and Payment Bonds (See Section 13 Information for Bidders) as specified in the contract documents. Bid security in the form of a certified check shall be subject to the same requirements as a bond.

(SIGNATURE PAGE TO FOLLOW)

(IF SOLE PROPRIETOR OR PARTNERSHIP)

IN WITNESS HERETO, the undersigned has set hand this _____ day of _____, 2023.

SIGNATURE OF BIDDER

TITLE

(IF CORPORATION)

IN WITNESS WHEREOF, the undersigned corporation has caused this instrument to be executed and its seal affixed by its duly authorized officers this _____ day of _____, 2023.

NAME OF CORPORATION

By: _____

Title: _____

Attest: _____

(SCHEDULE OF BID ITEMS TO FOLLOW)

ITEM NO.	SPEC SECTION	ITEM	UNIT	QTY	UNIT PRICE	AMOUNT
<u>Part 00200 - Temporary Features and Appurtenances</u>						
001	00210	Mobilization	LS	1	\$ _____	\$ _____
002	00221	Temporary Protection and Direction of Traffic	LS	1	\$ _____	\$ _____
003	00222	Temporary Signs	SQFT	596	\$ _____	\$ _____
004	00222	Portable Changeable Message Signs	EACH	4	\$ _____	\$ _____
005	00223	Flaggers	HOUR	560	\$ _____	\$ _____
006	00223	Pilot Cars	HOUR	170	\$ _____	\$ _____
<u>Part 00600 - Bases</u>						
007	00620	Cold Plane Pavement Removal, 3 Inches Deep	SQYD	44892	\$ _____	\$ _____
008	00640	Aggregate Shoulders	TON	250	\$ _____	\$ _____
<u>Part 00700 - Wearing Surfaces</u>						
009	00744	Level 3, 1/2 Inch ACP Mixture	TON	7900	\$ _____	\$ _____
010	00749	Extra for Asphalt Approaches	EACH	1	\$ _____	\$ _____
<u>Part 00800 - Permanent Traffic Safety and Guidance Devices</u>						
011	00840	Delineators, Type 1	EACH	152	\$ _____	\$ _____
012	00855	Bi-Directional Yellow Type IAR Markers, Recessed	EACH	378	\$ _____	\$ _____
013	00865	Thermoplastic, Sprayed, Surface, Non-Profiled	FOOT	53500	\$ _____	\$ _____
014	00867	Pavement Bar, Type B-HS	SQFT	24	\$ _____	\$ _____
015	00867	Pavement Legend, Type B-HS: "STOP"	EACH	2	\$ _____	\$ _____

TOTAL BID: _____

FOR DESCHUTES COUNTY USE ONLY	ADD _____ % FOR NON-RESIDENT BIDDER	_____
	TOTAL BID	_____

FIRST-TIER SUBCONTRACTOR DISCLOSURE FORM

Project Name: PAVING OF OLD BEND-REDMOND HWY: US 20 TO TUMALO RD

Bid #: W66139 Bid Closing Date: July 26, 2023 Time: 2:00 P.M.

Name of Bidding Contractor: _____

This form must be submitted at the location specified in the Invitation to Bid on the advertised bid closing date and within two working hours (4:00 p.m.) after the advertised bid closing time.

List below the name of each subcontractor that will be furnishing labor or materials and that is required to be disclosed, the category of work that the subcontractor would be performing and the dollar value of the subcontract. Enter "NONE" if there are no subcontractors that need to be disclosed. (ATTACH ADDITIONAL SHEETS IF NEEDED).

	NAME	DOLLAR VALUE	CATEGORY OF WORK
1)	_____	\$ _____	_____
2)	_____	\$ _____	_____
3)	_____	\$ _____	_____
4)	_____	\$ _____	_____
5)	_____	\$ _____	_____
6)	_____	\$ _____	_____
7)	_____	\$ _____	_____
8)	_____	\$ _____	_____

Failure to submit this form by the disclosure deadline will result in a non-responsive bid. A non-responsive bid will not be considered for award.

Form submitted by

Bidder name: _____

Contact name: _____ Phone number: _____

BID BOND

KNOW ALL MEN BY THESE PRESENTS, That _____

_____ ,

hereinafter called the Principal, and _____

_____ ,

a corporation duly organized under the laws of the State of _____ ,

having its principal place of business at _____

_____ , in the State of _____ ,

and authorized to do business in the State of Oregon, as Surety, are held and firmly bound unto the

County of Deschutes, hereinafter called the Obligee, in the penal sum of _____

_____ DOLLARS (\$ _____),

for the payment of which, well and truly to be made, we bind ourselves, our heirs, executors, administrators, successors and assigns, jointly and severally, firmly by these presents.

The condition of this Bond is that, whereas, the Principal is submitting a bid proposal for the PAVING OF OLD BEND-REDMOND HWY: US 20 TO TUMALO RD project hereby made a part hereof;

NOW THEREFORE, if the said bid proposal submitted by the said principal be accepted, and the contract be awarded to said Principal, and if the said Principal shall execute the proposed contract and shall furnish the Performance and Payment Bond as required by the bidding and contract documents with the time fixed by said documents, then this obligation shall be void, otherwise to remain in full force and effect. Signed and sealed this _____ day of _____, 2023.

SURETY:

CONTRACTOR:

Name

Name

By: _____

By: _____

Title: _____

Title: _____

CONTRACT

FOR

PAVING OF OLD BEND-REDMOND HWY: US 20 TO TUMALO RD

THIS CONTRACT is made and entered into, this _____ day of _____, 2023, by and between DESCHUTES COUNTY, a political subdivision of the State of Oregon, by and through its Board of County Commissioners, hereinafter called "County", and _____, an Oregon corporation, hereinafter called "Contractor."

WITNESSTH:

THAT the said Contractor, in consideration of the sums to be paid by the County in the manner and at the time herein provided, and in consideration of the other covenants and agreements herein contained, hereby agrees to perform and complete the work herein described and provided for and to furnish all necessary machinery, tools, apparatus, equipment, supplies, materials and labor and do all things in accordance with the applicable Plans, the applicable Standard Specifications, the Special Provisions and other required provisions bound herewith or incorporated therein, and in accordance with such alterations or modifications of the same as may be made by the County, and according to such directions as may from time to time be made or given by the Engineer under the authority and within the meaning and purpose of this Contract. This agreement shall be binding upon the heirs, executors, administrators, successors and assigns of the Contractor.

THAT the applicable Plans, the applicable Standard Specifications, the Special Provisions and other required provisions bound herewith or incorporated therein and the Schedule of Items bound herewith are hereby specifically referred to and by this reference made a part hereof, and shall by such reference have the same force and effect as though all of the same were fully written or inserted herein.

THAT the Contractor shall faithfully complete and perform all of the obligations of this Contract, and in particular, shall promptly, as due, make payment of all just debts, dues, demands and obligations incurred in the performance of said Contract; and shall not permit any lien or claim to be filed or prosecuted against the County, its agents or employees. It is expressly understood that the laws of the State of Oregon and the Ordinances of the County shall govern this Contract in all things.

THAT in consideration of the faithful performance of all of the obligations, general and special, herein set out, and in consideration of the faithful performance of the work as set forth in the Contract Documents in accordance with the directions and to the satisfaction of the Engineer, the County agrees to pay to the said Contractor the amount earned, as determined from the actual quantities of work performed, and taking into consideration any amounts that may be deductible and under the terms of the Contract, and to make such payments in the manner and at the times provided in the applicable provisions.

(SIGNATURE PAGE TO FOLLOW)

IN WITNESS WHEREOF, the parties hereto have subscribed their names and affixed their respective official seals as of the date first above written

CONTRACTOR

**BOARD OF COUNTY COMMISSIONERS
OF DESCHUTES COUNTY, OREGON**

BY: _____

ANTHONY DEBONE, CHAIR

TITLE: _____

PATTI ADAIR, VICE CHAIR

DATE: _____

PHIL CHANG, COMMISSIONER

ATTEST:

RECORDING SECRETARY

APPROVED AS TO CONTENT:

ROAD DEPARTMENT DIRECTOR

APPROVED AS TO FORM:

COUNTY LEGAL COUNSEL

Bond # _____

PERFORMANCE BOND

KNOW ALL MEN BY THESE PRESENTS: that

(Name of Contractor)

(Address of Contractor)

a _____, hereinafter called
(Corporation, Partnership, or Individual)

“Principal”, and _____
(Name of Surety)

hereinafter called “Surety”, are held and firmly bound unto Deschutes County, Oregon

hereinafter called “Owner”, in the penal sum of _____

_____ Dollars, \$(_____)
in lawful money of the United States, for the payment of which sum well and truly to be made,
we bind ourselves, successors, and assigns, jointly and severally, firmly by these presents.

THE CONDITION OF THIS OBLIGATION is such that whereas, the Principal entered into a
certain contract with the OWNER, dated the _____ day of _____, 2023, a copy of
which is hereto attached and made a part hereof for the construction of:

PAVING OF OLD BEND-REDMOND HWY: US 20 TO TUMALO RD

NOW THEREFORE, if Principal shall well, truly and faithfully perform its duties, all the
undertakings, covenants, terms, conditions, and agreements of said contract during the original
term thereof, and any extensions thereof which may be granted by Owner, with or without notice
to Surety and during the **two year guaranty period**, and if Principal shall satisfy all claims and
demands incurred under such contract, and shall fully indemnify and save harmless Owner from
all costs and damages which is may suffer by reason of failure to do so, and shall reimburse
and repay Owner all outlay and expense which Owner may incur in making good any default,
then this obligation shall be void; otherwise to remain in full force and effect.

PROVIDED FURTHER, that Surety, for value received hereby stipulates and agrees that no
change, extension of time, alteration or addition to the terms of the contract or to work to be
performed thereunder or the specifications accompanying the same shall in any wise affect its
obligation on this bond, and it does hereby waive notice of any such change, extension of time,
alteration or addition to the terms of the contract or to the work or the specifications.

PROVIDED, FURTHER, that no final settlement between Owner and Principal shall abridge the
right of any beneficiary hereunder, whose claim may be unsatisfied.

IN WITNESS WHEREOF, this instrument is executed in two counterparts, each one of which shall be deemed an original, this the _____ day of _____ 2023.

(SEAL)

PRINCIPAL: _____

By _____
Signature

Official Capacity

Attest: _____
Corporation Secretary

(SEAL)

SURETY: _____

[Add signatures for each surety if using multiple bonds]

BY ATTORNEY-IN-FACT:
[Power-of-Attorney must accompany each surety bond]

Name

Signature

Address

City State Zip

Phone Fax

NOTE: Date of bond must not be prior to date of Contract.
If Contractor is Partnership, all partners should execute bond.

Bond # _____

PAYMENT BOND

KNOW ALL MEN BY THESE PRESENTS: that

(Name of Contractor)

(Address of Contractor)

a _____, hereinafter called
(Corporation, Partnership, or Individual)

“Principal”, and _____
(Name of Surety)

hereinafter called “Surety”, are held and firmly bound unto Deschutes County, Oregon

hereinafter called “Owner”, in the penal sum of _____

_____ Dollars, \$(_____)
in lawful money of the United States, for the payment of which sum well and truly to be made,
we bind ourselves, successors, and assigns, jointly and severally, firmly by these presents.

THE CONDITION OF THIS OBLIGATION is such that whereas, the Principal entered into a
certain contract with the OWNER, dated the _____ day of _____, 2023, a copy of
which is hereto attached and made a part hereof for the construction of:

PAVING OF OLD BEND-REDMOND HWY: US 20 TO TUMALO RD

NOW, THEREFORE, if Principal shall promptly make payment to all persons, firms,
subcontractors, and corporations furnishing materials for or performing labor in the prosecution
of the work provided for in such contract, and any authorized or modification thereof, including
all amounts due for materials, lubricants, oil, gasoline, coal and coke, repairs on machinery,
equipment and tools, consumed or used in connection with the construction of such work, and
all insurance premiums on said work, and for all labor, performed in such work whether by
subcontractor or otherwise, then this obligation shall be void; otherwise to remain in full force
and effect.

PROVIDED, FURTHER, that Surety for value received hereby stipulates and agrees that no
change, extension of time, alteration or addition to the terms of the contract or to the work to be
performed thereunder or the specifications accompanying the same shall in any wise affect its
obligation on this bond, and it does hereby waive notice of any such change, extension of time,
alteration or addition to the terms of the contract or to the work or to the specifications.

PROVIDED, FURTHER, that no final settlement between Owner and Principal shall abridge the
right of any beneficiary hereunder, whose claim may be unsatisfied.

IN WITNESS WHEREOF, this instrument is executed in two counterparts, each one of which shall be deemed an original, this the _____ day of _____, 2023.

(SEAL)

PRINCIPAL: _____

By _____
Signature

Official Capacity

Attest: _____
Corporation Secretary

(SEAL)

SURETY: _____

[Add signatures for each surety if using multiple bonds]

BY ATTORNEY-IN-FACT:
[Power-of-Attorney must accompany each surety bond]

Name

Signature

Address

City State Zip

Phone Fax

NOTE: Date of bond must not be prior to date of Contract.
If Contractor is Partnership, all partners should execute bond.

SPECIAL PROVISIONS

PROJECT: PAVING OF OLD BEND-REDMOND HWY:
US 20 TO TUMALO RD

PROJECT #: W66139

CONTRACTING AGENCY:



**ROAD
DEPARTMENT**

**61150 SE 27TH STREET
BEND, OREGON 97702
PHONE: (541) 388-6581
FAX: (541) 388-2719
WEB: www.deschutescounty.gov/road**

PROFESSIONAL OF RECORD CERTIFICATION:

<p>Seal w/signature</p>  <p>REGISTERED PROFESSIONAL ENGINEER 83448PE OREGON NOVEMBER 10, 2009 CODY C. SMITH</p> <p>RENEWS: JUNE 30, 2024</p>	<p>I certify the Special Provision Section(s) listed below are applicable to the design for the subject project. Modified Special Provisions were prepared by me or under my supervision.</p> <p>Sections <u>00210 through 00867</u></p>
<p>Date Signed: <u>7-10-23</u></p>	

SPECIAL PROVISIONS

WORK TO BE DONE

The work to be done under this contract consists of the following on the PAVING OF OLD BEND-REDMOND HWY: US 20 TO TUMALO RD project:

1. Install and maintain temporary traffic control.
2. Perform cold plane pavement removal.
3. Construct asphalt concrete pavement.
4. Install permanent pavement markings and delineation.
5. Perform additional and incidental work as called for by the specifications and plans.

APPLICABLE SPECIFICATIONS

The Specification that is applicable to the Work on this Project is the 2021 edition of the "Oregon Standard Specifications for Construction."

All number references in these Special Provisions shall be understood to refer to the Sections and subsections of the Standard Specifications and Supplemental Specifications bearing like numbers and to Sections and subsections contained in these Special Provisions in their entirety.

Copies of the Oregon Standard Specifications may be purchased or viewed online at

http://www.oregon.gov/ODOT/Business/Pages/Standard_Specifications.aspx.

APPLICABLE RULES

The rules applicable to this contract are the Attorney General's Model Public Contract Rules, Chapter 137-046 and Chapter 137-049, as presently constituted and Deschutes County Code (DCC) Chapter 2.37. The provisions of DCC Chapter 2.37.150 are incorporated herein by reference. These provisions may be viewed at the following web address:

<http://www.co.deschutes.or.us/administration/page/deschutes-county-code>

CONTRACT TIME

The Contractor shall complete all Work to be done under the Contract not later than October 13, 2023.

CLASS OF WORK

The Class of Work for this Project is Asphalt Concrete Paving and Oiling.

SECTION 00110 - ORGANIZATION, CONVENTIONS, ABBREVIATIONS AND DEFINITIONS

Comply with Section 00110 of the Standard Specifications modified as follows:

00110.20 Definitions - Replace the definitions of the words and phrases list below with the following definitions:

Agency – County of Deschutes

Bid Booklet - The version that can be accessed and printed from the Deschutes County Bids and RFPs website, which contains the information identified in 00120.10.

Engineer - The Road Department Director of Deschutes County acting either directly or through his authorized representatives.

SECTION 00120 - BIDDING REQUIREMENTS AND PROCEDURES

Comply with Section 00120 of the Standard Specifications modified as follows:

00120.00 Prequalification of Bidders – Replace the last paragraph with the following:

Deschutes County Road Department will regularly evaluate the performance of Contractors on its projects for purposes of responding to reference checks, future prequalification and determinations of responsibility.

00120.01 General Bidding Requirements - Replace this subsection, except for the subsection number and title, with the following:

Bidders shall submit bids by paper.

The standard prequalification forms furnished by the ODOT Procurement Office shall be used by the bidder to file authorized signatures with Deschutes County Road Department. Signatures are of personnel authorized to submit Bids, modify Bids, or withdraw Bids.

00120.05 Request for Plans, Special Provisions, and Bid Booklets – Replace this subsection, except for the subsection number and title, with the following:

Bidders shall obtain solicitation documents from the Deschutes County Bids and RFPs website:

<https://www.deschutescounty.gov/rfps>

Each request shall include both the name of the person ordering or obtaining the Solicitation Documents, and the name of the Entity intending to use them. The Agency will add the name of the Entity intending to use the Solicitation Documents to the list of Holders of Bidding Plans. Bidders are cautioned that only Solicitation Documents obtained properly from the Deschutes County website may be used to submit Bids.

Only paper Bids will be accepted.

Copies of the Oregon Standard Specifications may be purchased or viewed online at

http://www.oregon.gov/ODOT/Business/Pages/Standard_Specifications.aspx.

The Plans, which are applicable to the Work to be performed under the Contract, are bound herewithin.

00120.10 Bid Booklet – Replace this subsection, except for the subsection number and title, with the following:

The Bidding Documents Booklet may include, but is not limited to:

- Cover Page
- Index
- Invitation to Bid
- Information for Bidders
- Bid Proposal Form
- Schedule of Bid Items
- Subcontractor Disclosure Form
- Bid Guaranty Form
- Contract Form (for review only)
- Payment and Performance Bond Forms (for review only)

Depending on the Class of Project, other certificates or statements may be bound within the Bidding Documents Booklet. Plans, specifications, and other documents referred to in the Bidding Documents Booklet will be considered part of the Bid.

00120.30 Changes to Plans, Specifications, or Quantities before Opening of Bids –

Replace all instances of “ODOT eBIDS” with “Deschutes County Bids and RFPs”.

Replace the first paragraph with the following:

The Agency reserves the right to issue Addenda making changes or corrections to the Plans, Specifications, or quantities. The Agency will provide Addenda only by publishing them on the Agency's web site at:

<https://www.deschutescounty.gov/rfps>

Delete the last paragraph.

00120.40(a)(2) Electronic Bids – Delete this subsection.

00120.40(c)(2) Electronic Bid Schedule Entries – Delete this subsection.

00120.40(d) Bidder's Address and Signature Pages – Replace this subsection with the following:

Bidders shall include in the Bid the address to which all communication concerning the Bid and Contract should be sent. The Bid shall be signed by a duly authorized representative of the Bidder.

00120.40(e)(2) Bid Guaranty with Electronic Bids – Delete this subsection.

00120.40(f) Disclosure of First-Tier Subcontractors – Under the paragraph “The Subcontractor Disclosure Form may be submitted for a paper Bid...” replace the second bulleted item with the following:

- By removing it from the paper Bid Booklet, filling it out and submitting it separately to the Deschutes County Public Works Engineering and Construction Division at the address given in the Bid Booklet.

Delete the third bulleted item.

Delete the paragraph which begins “The Subcontractor Disclosure Form may be submitted for an electronic Bid either:”

Replace the paragraph that begins “Subcontractor Disclosure forms submitted by...” with the following:

Subcontractor Disclosure Forms submitted by any method will be considered late if not received by the Agency within two working hours of the time designated for receiving Bids.

00120.45 Submittal of Bids – Replace this subsection, except for the subsection number and title, with the following:

Bids shall be submitted in the manner and prior to the time listed in the Bidding Documents Booklet. Bids may be submitted by mail, parcel delivery service or hand delivery. Bids submitted after the time set for receiving Bids will not be opened or considered. The Agency assumes no responsibility for the receipt and return of late Bids.

00120.50 Submitting Bids for More than One Contract – Delete this subsection.

00120.60(a) Paper Bids – Replace all references to “ODOT Procurement Office” with “Agency.”

Delete the third bullet point.

00120.60(b) Electronic Bids – Delete this subsection.

00120.70 Rejection of Nonresponsive Bids – Add the following bullet to the end of the bullet list:

- The Agency determines that any Pay Item is significantly unbalanced to the potential detriment of the Agency.

00120.95 Opportunity for Cooperative Arrangement – Delete this subsection.

SECTION 00130 – AWARD AND EXECUTION

Comply with Section 00130 of the Standard Specifications modified as follows:

00130.10 Award of Contract – Replace the paragraph that begins “The Agency will provide Notice of Intent...” with the following:

The Agency will provide Notice of Intent to Award on the Agency’s website:

<https://www.deschutescounty.gov/rfps>

Delete the paragraph that begins “The Award will not be final until...”

00130.15 Right to Protest Award – Replace this subsection, except for the subsection number and title, with the following:

Adversely affected or aggrieved Bidders, limited to the three apparent lowest Bidders and any other Bidder directly in line for Contract Award, may submit to the Board of County Commissioners of Deschutes County a written protest of the Agency’s intent to Award within five working days following the Bid Opening. The protest shall specify the grounds upon which it is based.

The Agency will not consider late protests.

00130.50 Execution of Contract and Bonds:

(a) By the Bidder – In the sentence that begins “The successful Bidder...” replace “ODOT Procurement Office – Construction” with “Agency”.

(b) By the Agency – In the sentence that begins “Within 7 Calendar Days...” replace “7” with “21 (twenty-one)”.

SECTION 00140 – SCOPE OF WORK

Comply with Section 00140 of the Standard Specifications.

SECTION 00150 - CONTROL OF WORK

Comply with Section 00150 of the Standard Specifications modified as follows:

00150.05 Cooperative Arrangements – Replace this subsection, except for the subsection number and title, with the following:

Agency is not, by virtue of this Contract, a partner or joint venturer with Contractor in connection with activities carried out under this Contract, and shall have no obligation with respect to Contractor's debts or any other liabilities of each and every nature.

00150.15(b) Agency Responsibilities - Replace this subsection, except for the subsection number and title, with the following:

The Engineer will:

- Provide copies of plans and specifications.
- Evaluate grade for acceptance at each course of material.
- Perform measurements and calculations for pay quantities.
- Perform final "as constructed" measurements.

00150.15(c) Contractor Responsibilities – Replace this subsection, except for the subsection number and title, with the following:

The Contractor shall:

- Layout and set construction stakes and marks to establish the lines, grades, Slopes, Cross Sections and curve super-elevations for Roadwork to construct the Project as shown and specified, by means approved by the Engineer.
- Make calculations, field notes and survey drawings for the layout and control of work as are necessary to construct the Project as specified.
- Provide original or copies of notes, calculations and drawings as requested.
- Preserve survey monuments and control stations as governed by applicable law.
- Establish control stations as necessary to control the Project.
- Replace and augment control stations as necessary to control the Project.
- Remove and dispose of all flagging, lath, stakes and other temporary staking material after the Project is completed.
- Protect from damage or disturbance any Utility that remains within the area in which Work is being performed. Maintain and re-establish location marks according to OAR 952-001-0090(3)(a). Coordinate re-establishment of the location marks with the associated Utility.
- Determine the exact location before excavating within the tolerance zone according to OAR 952-001-0090(3)(c);
- In addition to the notification required in OAR 952-001-0090(6), notify the Engineer and the Utility as soon as the Contractor discovers any previously unknown Utility conflicts or issues. Contrary to the OAR, stop excavating until directed by the Engineer and allow the Utility a minimum of two weeks to relocate or resolve the previously unknown Utility issues; and

00150.50(c) Contractor Responsibilities – Replace the bullet that begins "Protect from damage or disturbance any Utility that remains..." with the following bullet:

- Protect from damage or disturbance any Utility that remains within the area in which Work is being performed. Maintain and re-establish location marks according to OAR 952-001-0090(3)(a). Coordinate re-establishment of the location marks with the associated Utility;

Replace the bullet that begins "Determine the exact location before excavating within ..." with the following bullet:

- Determine the exact location before excavating within the tolerance zone according to OAR 952-001-0090(3)(c);

Replace the bullet that begins "In addition to the notification required in OAR 952-001-0090(5), notify the Engineer..." with the following bullet:

- In addition to the notification required in OAR 952-001-0090(6), notify the Engineer and the Utility as soon as the Contractor discovers any previously unknown Utility conflicts or issues. Contrary to the OAR, stop excavating until directed by the Engineer and allow the Utility a minimum of two weeks to relocate or resolve the previously unknown Utility issues; and

00150.50(f) Utility Information:

There are no anticipated conflicts with Utilities. The Contractor shall contact those Utilities having buried facilities and request that they locate and mark them for their protection prior to construction.

SECTION 00160 – SOURCE OF MATERIALS

Comply with Section 00160 of the Standard Specifications modified as follows:

00160.30 Agency-Furnished Materials – Add the following paragraph:

No Agency materials are being offered for use on this project. Contractor shall provide all required materials.

00160.40 Agency-Furnished Sources– Add the following paragraph:

No Agency sources are being offered for use on this project. Contractor shall provide all required materials.

SECTION 00165 - QUALITY OF MATERIALS

Comply with Section 00165 of the Standard Specifications modified as follows:

00165.03 Testing by Agency – Delete this subsection.

00165.04 Costs of Testing – Delete this subsection.

00165.50(b)(1) Specification Materials – Delete the second sentence.

00165.10(a) Field-Tested Materials – Add the following sentence to the end of this subsection:

This is a Type D project.

SECTION 00170 – LEGAL RELATIONS AND RESPONSIBILITIES

Comply with Section 00170 of the Standard Specifications modified as follows:

Add the following subsection:

00170.09 Debt Limitation - This Contract is expressly subject to the debt limitation of Oregon counties set forth in Article XI, Section 10, of the Oregon Constitution, and is contingent upon funds being appropriated therefore. Any provision herein which would conflict with law are deemed inoperative to that extent.

00170.65(b-1) Minimum Wage Rates – Replace the last two paragraphs in this subsection with the following:

The applicable prevailing wage rates for this project are the most recent version published by the Oregon Labor and Industries at the time the Project was initially advertised (Prevailing Wage Rates for Public Works Contracts and July 5, 2023 addenda). The wage rates can be found at the following website:

https://www.oregon.gov/boli/WHD/PWR/Pages/pwr_state.aspx

00170.70(a) Insurance Coverages - Add the following to the end of this subsection:

The following insurance coverages and dollar amounts are required pursuant to this subsection:

Insurance Coverages	Combined Single Limit per Occurrence	Annual Aggregate Limit
Commercial General Liability	\$2,000,000	\$5,000,000
Commercial Automobile Liability	\$1,000,000	(aggregate limit not required)

(d) Additional Insured – Replace this subsection except for the subsection number and title with the following:

The liability insurance coverages of 00170.70(a) shall include an Additional Insured Endorsement specifying the “Deschutes County, and its respective officers, agents, employees, and volunteers and the Deschutes County Board of Commissioners” as Additional Insureds, but only with respect to the Contractor's activities to be performed under the Contract. Coverage shall be primary and non-contributory with any other insurance and self-insurance. The liability coverages of 00170.70(a) that are permitted by the Agency to be obtained by an appropriate Subcontractor shall include all of the foregoing as Additional Insureds and shall also include the Contractor and its officers and employees as Additional Insureds.

Additional Insured Endorsements on the Commercial General Liability shall be written on ISO Form CG 20 10 07 04, or equivalent, with respect to liability arising out of ongoing

operations and ISO Form CG 20 37 07 04, or equivalent, with respect to liability arising out of completed operations. Additional Insured Endorsements shall be submitted with the Certificate(s) of Insurance and must be acceptable to the Agency.

Add the following as Additional Insureds under the Contract:

- Deschutes County and its officers, agents, employees, and volunteers
- Deschutes County Board of Commissioners

(g) Certificate(s) of Insurance - Replace this subsection except for the subsection number and title with the following:

As evidence of the insurance coverages required by the Contract, the Contractor shall furnish Certificate(s) of Insurance to the Agency at the time(s) provided in 00130.50(a). As evidence of insurance coverages required by the Contract but permitted by the Agency under 00170.70(a) to be obtained by an appropriate Subcontractor, the Contractor shall furnish Certificate(s) of Insurance to the Agency for such coverages together with the Contractor's request under 00180.21 for approval of the subcontract with that Subcontractor. The Certificate(s) shall:

- List "Deschutes County and its officers, agents, employees, and volunteers and the Deschutes County Board of Commissioners" as a Certificate holder and as an endorsed Additional Insured;
- Include all required endorsements or copies of the applicable policy language effecting coverage required by the Contract;
- Specify that all liability insurance coverages shall be primary and non-contributory with any other insurance and self-insurance, with exception of Workers' Compensation;
- Include a list of all policies that fall under the Excess/Umbrella Insurance if Excess or Umbrella Insurance is used to meet the minimum insurance requirement.
- Be endorsed with a waiver of subrogation endorsement for Workers' Compensation, waiving the insured's right of subrogation against the Agency.

00170.72 Indemnity/Hold Harmless - Add the following paragraph and bullets to the end of this subsection:

Extend indemnity and hold harmless to the Agency and the following:

- Deschutes County and its officers, agents, and employees
- Deschutes County Board of Commissioners

SECTION 00180 – PROSECUTION AND PROGRESS

Comply with Section 00180 of the Standard Specifications modified as follows:

00180.40(c) Specific Limitations - Limitations of operations specified in these Special Provisions include, but are not limited to, the following:

Limitations	Subsection
Cooperation with Utilities	00150.50
On-Site Work	00180.40(b)
Contract Time	00180.50(h)
Right-of-Way and Access Delays	00180.65
Closed Lanes	00220.40(e)(1)
Noise Control	00290.32
Maintenance Under Traffic	00620.43
Opening Sections to Traffic	00744.51

The Contractor shall be aware of and subject to schedule limitations in the Standard Specifications that are not listed in this subsection.

00180.41 Project Work Schedules - After the paragraph that begins "One of the following Type..." add the following paragraph:

In addition to the "look ahead" Project Work schedule, a Type A schedule as detailed in the Standard Specifications is required on this Contract.

00180.50(h) Contract Time - The Contractor shall complete all Work to be done under the Contract not later than October 13, 2023.

SECTION 00190 – MEASUREMENT OF PAY QUANTITIES

Comply with Section 00190 of the Standard Specifications.

SECTION 00195 - PAYMENT

Comply with Section 00195 of the Standard Specifications modified as follows:

00195.12(d) Steel Materials Pay Item Selection - Add the following to this subsection:

No Pay Items under this Contract qualify for the steel escalation/de-escalation program for this Project.

00195.50(b) Retainage – Replace the first paragraph of this subsection with the following:

The amount to be retained from progress payments will be 5% of the value of Work accomplished, and will be retained in one of the forms specified in Subsection (c) below. No retainage will be withheld from Work performed as Force Account Work, escalation/de-escalation, bonuses, or other items decided by the Agency.

00195.50(c-2) Cash, Alternate B (Retainage Surety Bond) - Delete this subsection.

00195.50(c-3) Bonds and Securities – Delete this subsection.

00195.50(d) Release of Retainage – Replace this subsection with the following:

As the Work progresses, release of the amounts retained under (b) above will only be considered for Pay Items that have been satisfactorily completed. For purposes of this Subsection, a Pay Item will be considered satisfactorily completed only if all of the Work for the Pay Item is complete and all contractual requirements pertaining to the Pay Item and Work have been satisfied. Work not included in a Pay Item, or which constitutes part of an uncompleted Pay Item, will not be regarded as satisfactorily completed Work for the purposes of this Subsection.

A determination of satisfactory completion of Pay Items or Work or release of retainage shall not be construed as acceptance or approval of the Work and shall not relieve the Contractor of responsibility for defective Materials or workmanship or for latent defects and warranty obligations.

The Contractor shall comply with all applicable legal requirements for withholding and releasing retainage and for prompt payments, including but not limited to those in ORS Chapters 279C and 701, and 49 CFR 26.29.

SECTION 00196 – PAYMENT FOR EXTRA WORK

Comply with Section 00196 of the Standard Specifications.

SECTION 00197 – PAYMENT FOR FORCE ACCOUNT WORK

Comply with Section 00197 of the Standard Specifications.

SECTION 00199 - DISAGREEMENTS, PROTESTS, AND CLAIMS

Comply with Section 00199 of the Standard Specifications modified as follows:

00199.40 Claim Decision; Review; Exhaustion of Administrative Remedies – Replace the second and third paragraphs with the following:

If the Engineer denies the claim for additional compensation or a combination of additional compensation and Contract Time, in full or in part, according to 00199.40(a), the Contractor may request review of the denial. The disputed claim may then be resolved, in full or in part, at any of the three progressive steps of claim review procedure as set forth in (b) through (d) of this Subsection.

If the Engineer has denied a claim, in full or in part, for Contract Time only according to 00180.80, or has denied a claim, in full or in part, for correction of final compensation according to 00195.95, those disputed claims may then be resolved, in full or in part, at any of the three progressive steps of claim review procedure as specified in (b) through (d) of this Subsection.

Delete the fifth paragraph.

00199.40(b-e) - Replace these subsections in their entirety with the following:

00199.40(b) Step 1: Board of Commissioners Review – The Contractor shall request that the Engineer arrange for a hearing during a regularly scheduled Board of Commissioners Meeting in order to present the denied or partially denied claim for formal review and discussion. The meeting will take place within 21 Calendar Days of the Agency’s receipt of the request, or as otherwise agreed by the parties.

If the Board of Commissioners determines that the Contractor must furnish additional information or documentation to allow proper analysis of the claim, the Engineer will prepare a Board meeting agenda item for a second hearing within 14 Calendar Days, or as otherwise agreed by the parties, at which the Contractor shall present the requested information or documentation.

If the Contractor does not accept the Step 1 decision, the Contractor may, within 10 Calendar Days of receipt of the written decision, request in writing through the Engineer that the claim be advanced to Step 3 or 4 (see (c) and (d) below).

00199(c) Step 2: Arbitration - At this step, the claim will be resolved by binding arbitration before a single arbitrator according to the Construction Industry Arbitration Rules of the American Arbitration Association or such other arbitration service and rules as agreed by the parties.

Arbitration filing costs and any arbitrator's fees will be divided equally between the Agency and the Contractor.

00199(d) Step 3: Litigation – This step applies to appeals of arbitration awards issued in Step 2 at 00199.40(c) above, according to ORS 36.600 through ORS 36.740.

The Contractor must follow each step in order, and exhaust all available administrative remedies before resorting to litigation. Lawsuits must be properly filed in a court of competent jurisdiction within 6 months from the date of the final decision that exhausted the Contractor's available administrative remedies under this Section 00199.

The Contractor shall comply with 00170.00.

SECTION 00210 - MOBILIZATION

Comply with Section 00210 of the Standard Specifications.

SECTION 00220 - ACCOMMODATIONS FOR PUBLIC TRAFFIC

Comply with Section 00220 of the Standard Specifications modified as follows:

00220.02(c) Bicyclists - Add the following to the end of the bulleted list:

- During flagging and pilot car operations, allow bicycles to clear the work zone before allowing oncoming traffic to enter the work zone.

00220.40(e-1) Closed Lanes - Replace this subsection, except for the subsection number and title, with the following:

One Traffic Lane may be closed when allowed, shown, or directed during the following periods of time except as indicated in 00220.40(e)(2):

- Daily, Monday through Friday between 7:00 a.m. and 6:00 p.m.

SECTION 00221 - COMMON PROVISIONS FOR WORK ZONE TRAFFIC CONTROL

Comply with Section 00221 of the Standard Specifications modified as follows:

00221.90(b) Temporary Protection and Direction of Traffic - Delete the bullet that begins "Moving temporary barrier to and from Contractor's stockpile areas".

SECTION 00222 – TEMPORARY TRAFFIC CONTROL SIGNS

Comply with Section 00222 of the Standard Specifications modified as follows:

00222.40(e) Temporary Sign Placement - Add the following to the end of the bullet list:

- Install "ROAD WORK AHEAD" (W20-1-36) signs on Old Bend-Redmond Highway, according to the "TCD Spacing Table" shown on the Standard Drawings or as modified by the Plans.
- Install beyond each end of the Project, facing outgoing traffic, an "END ROAD WORK" (CG20-2A-24) sign a distance of $(A \div 2)$ according to the "TCD Spacing Table" shown on the Standard Drawings or as modified by the Plans.
- When the existing centerline striping on Old Bend-Redmond Highway is obliterated, do the following:
 - Place a "NO CENTER LINE" (W8-12) sign with a 24 by 18-inch "NEXT __ MILES" (W7-3aP) rider, approximately 2,500 feet in advance of each end of the Project.
 - Place "NO CENTER LINE" (W8-12) signs on approximately 2 mile intervals for each direction of traffic.
- For paving operations on non-freeways, place "ABRUPT EDGE" (CW21-9) signs as shown.
- For all other moving operations that do not create an abrupt edge adjacent to traffic, omit the "ABRUPT EDGE" signs.
- Install two 60 by 24-inch "ROAD WORK NEXT ____ MILES" (CG20-1) signs on Old Bend-Redmond Highway, in advance of the "ROAD WORK AHEAD" (W20-1) sign according to sign spacing "A" from the "TCD Spacing Table" shown on the Standard Drawings.
- Install a "Bicycle ON ROADWAY" (CW11-1) symbol sign and a 24 by 18-inch "NEXT XX MILES" (W7-3aP) plaque according to "Sign Spacing A", from the "TRAFFIC CONTROL DEVICES SPACING TABLE" shown on the Standard Drawings, after the "ROAD WORK AHEAD" sign. Install a "Bicycle ON ROADWAY" symbol sign on 1 mile

spacing through the affected area. Keep the signs in place until completion of the Shoulder or bikeway final surface.

- During pilot car operations, install a 15 by 24-inch "WAIT FOR PILOT CAR" (CR4-20) sign at stop-controlled side roads and accesses intersecting the Highway within the limits of the pilot car operation at the following locations:
 - Schibel Road
 - Jonathon Court
 - Rodeo Drive
 - Pohaku Road
 - Glacier View Drive
- During pilot car operations, install a 12 by 12-inch "WAIT FOR PILOT CAR" (CR4-20a) sign in private residential driveways accessing the Highway within the limits of the pilot car operation. Place the sign in the driveway facing the private residence and so the sign face is not visible to Public Traffic on the Highway. Do not use the sign for apartments, condominiums or business accesses.
- At accesses, side roads, or residential driveways where "WAIT FOR PILOT CAR" (CR4-20) signs are installed, do not allow traffic to be stopped or held for longer than 20 minutes.
- In addition to the signs, public notification (e.g. flyers, door hangers) may be used to inform the residents that may be affected by the pilot car operations and the "WAIT FOR PILOT CAR" signs.
- For each location of the "WAIT FOR PILOT CAR" sign, closely monitor for traffic compliance, operation, and safety at least once per hour during pilot car operations. If operational issues are observed, or if notified of operational issues, at stop-controlled accesses or side roads utilizing the "WAIT FOR PILOT CAR" (CR4-20) sign, remove the sign and replace it with a flagger.

00222.80(a) Area Basis - Add the following to the end of the paragraph that begins "Temporary signs will...":

No measurement of quantities will be made for "CONSTRUCTION VEHICLE DO NOT FOLLOW" (CW23-14) signs.

No measurement of quantities will be made for "WAIT FOR PILOT CAR" (CR4-20) or (CR4-20a) signs.

00222.90 Payment - Add the following to the end of the paragraph that begins "No separate or...":

No separate or additional payment will be made for furnishing, installing, and maintaining 72 by 24-inch "CONSTRUCTION VEHICLE DO NOT FOLLOW" (CW23-14) signs. Payment will be included in 00221.90(b).

No separate or additional payment will be made for furnishing, installing, and maintaining "WAIT FOR PILOT CAR" (CR4-20) or (CR4-20a) signs. Payment will be included in 00221.90(b).

SECTION 00223 - WORK ZONE TRAFFIC CONTROL LABOR AND VEHICLES

Comply with Section 00223 of the Standard Specifications.

SECTION 00224 - TEMPORARY TRAFFIC CHANNELIZING DEVICES

Comply with Section 00224 of the Standard Specifications modified as follows:

00224.80 Measurement – Replace this section, except for the subsection number and title, with the following:

No measurement will be made for work performed under this section.

00224.90 Payment – Replace this subsection, except for the subsection number and title, with the following:

Work performed under this section will be paid for according to 00221.90(b).

SECTION 00225 - TEMPORARY PAVEMENT MARKINGS

Comply with Section 00225 of the Standard Specifications modified as follows:

00225.80 Measurement – Replace this section, except for the subsection number and title, with the following:

No measurement will be made for work performed under this section.

00225.90 Payment – Replace this subsection, except for the subsection number and title, with the following:

Work performed under this section will be paid for according to 00221.90(b).

SECTION 00290 - ENVIRONMENTAL PROTECTION

Comply with Section 00290 of the Standard Specifications modified as follows:

00290.32 Noise Control - Add the following paragraph to the end of this subsection:

Review Deschutes County Code Title 8.08 which describes noise control regulations. Obtain and be responsible for necessary permits described in Deschutes County Code Title 8.08. Comply with the applicable noise control requirements for Project Work.

SECTION 00620 - COLD PLANE PAVEMENT REMOVAL

Comply with Section 00620 of the Standard Specifications modified as follows:

00620.40(e) Warning Signs - Replace this subsection, except for the subsection number and title, with the following:

Provide warning signs as required where abrupt or sloped drop-offs occur at the edge of the existing or new surface according to Sections 00221 and 00222.

00620.43 Maintenance Under Traffic - Replace this subsection, except for the subsection number and title, with the following:

Traffic is not allowed on the cold planed surface. Before opening the area to traffic, pave the surface according to 00744.51.

SECTION 00640 - AGGREGATE BASE AND SHOULDERS

Comply with Section 00640 of the Standard Specifications modified as follows:

00640.41 Mixing, Hauling, and Placing – Add the following to the end of this subsection:

Place aggregate shoulder material with equipment that is capable of maintaining a consistent shoulder cross slope and width, and without casting material beyond the ordinary limits of the aggregate shoulder as shown in the Plans.

00640.80 Measurement – Add the following to the end of this subsection:

Aggregate shoulder material which is placed or cast beyond the ordinary limits of the aggregate shoulder as shown in the Plans will be deducted from the total ticket quantity based on visual estimation by the Engineer.

00640.90 Payment – Add the following to the end of this subsection:

No payment will be made for aggregate shoulder material which is placed or cast beyond the ordinary limits of the aggregate shoulder according to 00640.80.

SECTION 00730 - EMULSIFIED ASPHALT TACK COAT

Comply with Section 00730 of the Standard Specifications modified as follows:

00730.11 Emulsified Asphalt - In the paragraph that begins "Obtain samples according to AASHTO T 40..." replace the words "AASHTO T 40" with the words "AASHTO R 66".

00730.42 Preparation of Underlying Surfaces – Add the following to the end of this subsection:

Immediately before applying the tack coat, the surface to be tacked shall be clean and dry. Clean all loose material by brooming, flushing with water or other approved methods. Pavement surface shall be cleaned to the apparent existing edge of pavement. Application of tack coat shall not commence until surface cleanliness has been verified and approved by the Engineer.

00730.44 Applying Tack Coat - Apply the Emulsified Asphalt with a pressure distributor conforming to 00730.22, unless otherwise allowed. Apply the Emulsified Asphalt to the prepared surface at a rate between 0.05 and 0.20 gallons per square yard as directed and with the Emulsified Asphalt temperature between 140 °F and 185 °F as recommended by the manufacturer. Refer to the manufacturer's recommendations for tack coat application rates for the underlying surface type and type of emulsion used. Application rates for tack coat diluted according to 00730.11 will be increased as necessary to provide the same amount of residual asphalt as the application rates specified above.

Do not place hot mixed asphalt concrete Pavement or Emulsified Asphalt Concrete Pavement on the tack coat until the Emulsified Asphalt separates from the water (breaks), but before it loses its tackiness. Refer to manufacturer recommendations regarding break/set time. Minimize truck traffic on the tacked surface.

00730.90 Payment - Replace this subsection, except for the subsection number and title, with the following:

No separate or additional payment will be made for Emulsified Asphalt tack coat. Approximately 2 Tons of Emulsified Asphalt in tack coat will be required on this Project.

SECTION 00744 - ASPHALT CONCRETE PAVEMENT

Comply with Section 00744 of the Standard Specifications modified as follows:

00744.11(a) Asphalt Cement - Add the following to the end of this subsection:

Provide PG 58-34ER grade asphalt cement for this Project.

00744.40 Season and Temperature Limitations – Replace this subsection, except for the subsection number and title, with the following:

Place ACP when the temperature of the surface that is to be paved is not less than the temperature indicated:

Nominal Compacted Thickness of Individual Lifts and Courses as shown on the Typical Section of the Plans	All Levels Surface Temperature*	Level 1 and Level 2 All Courses		Level 3 Travel Lane Wearing Course		All Other Courses	
		From	To	From	To	From	To
		Inclusive		Inclusive		Inclusive	
Less than 2 inches	60 F	All Year**		All Year**		All Year**	
2 inches – 2 1/2 inches	50 F	All Year**		All Year**		All Year**	
Greater than 2 1/2 inches	40 F	All Year**		All Year**		All Year**	
Temporary	40 F	All Year**		All Year**		All Year**	

* Do not use field burners or other devices to heat the Pavement surface to the specified minimum temperature.

** If placing ACP between March 15 and September 30, temperature requirement may be lowered 5 °F.

00744.44(a)(2) Wearing Course - Replace the paragraph that begins "Construct longitudinal joints ..." with the following paragraph:

Construct longitudinal joints two inches from permanent lane markings, or as shown or directed.

00744.44(b) Drop-Offs - Replace the bullet that begins "Provide warning signs and markings..." with the following bullet:

- Provide warning signs and markings according to Sections 00221, 00222, 00224 and 00225 where abrupt or sloped edge drop-offs greater than 1 inch in height occur.

Add the following subsection:

00744.51 Opening Sections to Traffic - Schedule work so that, during the same shift, the surfaces being paved are paved full width and length through the wearing Course before opening to traffic.

SECTION 00749 - MISCELLANEOUS ASPHALT CONCRETE STRUCTURES

Comply with Section 00749 of the Standard Specifications.

SECTION 00840 - DELINEATORS AND MILEPOST MARKER POSTS

Comply with Section 00840 of the Standard Specifications.

SECTION 00850 - COMMON PROVISIONS FOR PAVEMENT MARKINGS

Comply with Section 00850 of the Standard Specifications modified as follows:

00850.45 Installation – Add the following to the end of this subsection:

Do not place liquid thermoplastic striping materials within one week of a rainfall event without prior written approval from the Engineer.

SECTION 00855 - PAVEMENT MARKERS

Comply with Section 00855 of the Standard Specifications.

SECTION 00865 - LONGITUDINAL PAVEMENT MARKINGS - DURABLE

Comply with Section 0865 of the Standard Specifications.

SECTION 00867 - TRANSVERSE PAVEMENT MARKINGS - LEGENDS AND BARS

Comply with Section 00867 of the Standard Specifications.

###

DESCHUTES COUNTY ROAD DEPARTMENT

PLANS FOR

PAVING OF OLD BEND REDMOND HWY: US 20 TO TUMALO RD

JULY 2023

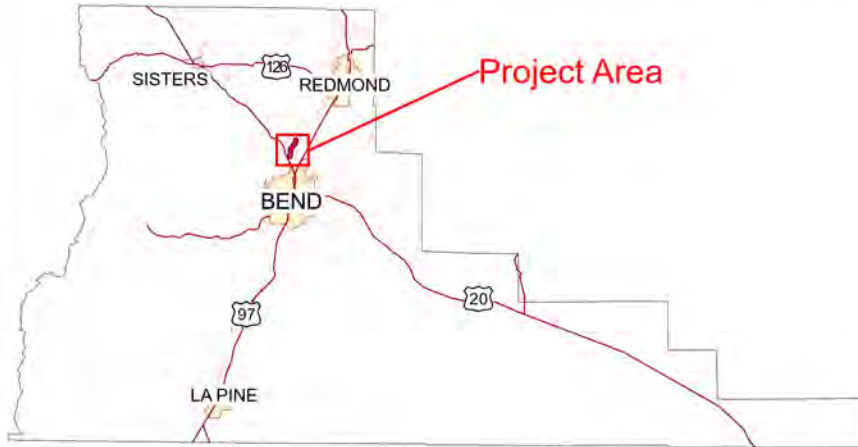

INDEX OF SHEETS

Sheet #	Description
1	COVER SHEET
2	TYPICAL SECTION
3	DETAILS
4	PLAN---Sta 26+90 To 37+00
5	PLAN---Sta 37+00 To 47+00
6	PLAN---Sta 47+00 To 57+00
7	PLAN---Sta 57+00 To 67+00
8	PLAN---Sta 67+00 To 77+00
9	PLAN---Sta 77+00 To 87+00
10	PLAN---Sta 87+00 To 97+00
11	PLAN---Sta 97+00 To 107+00
12	PLAN---Sta 107+00 To 117+00
13	PLAN---Sta 117+00 To 127+00
14	PLAN---Sta 127+00 To 132+00
15	PLAN---Sta 132+00 To 142+00
16	PLAN---Sta 142+00 To END

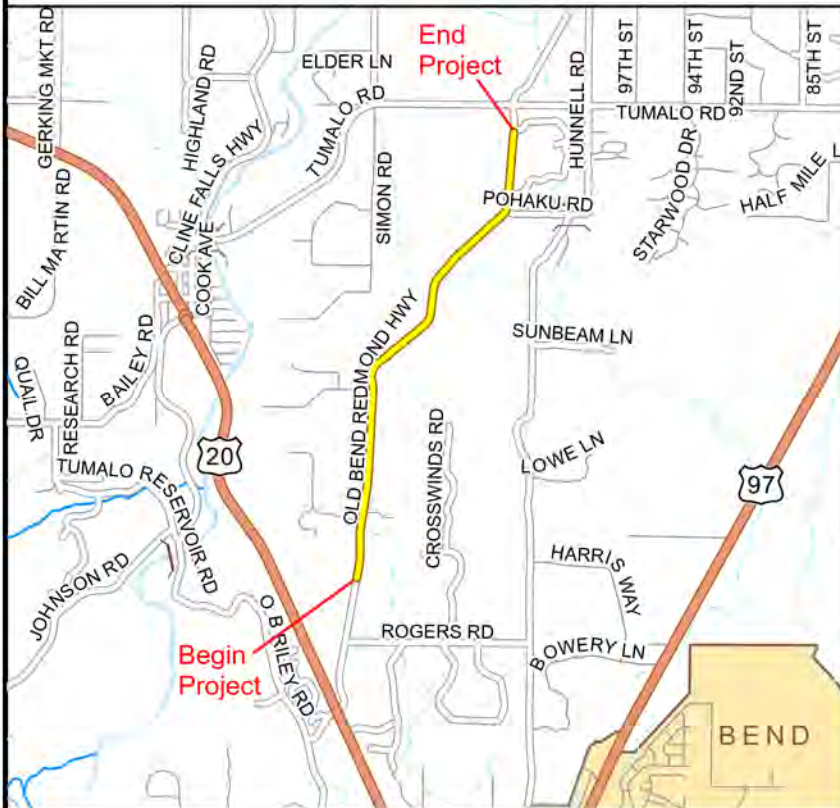

OREGON STANDARD DRAWING NO.

RD610	ASPHALT CONCRETE PAVEMENT (ACP) DETAILS
TM500	PAVEMENT MARKINGS STANDARD DETAIL BLOCKS
TM502	PAVEMENT MARKINGS STANDARD DETAIL BLOCKS
TM503	PAVEMENT MARKINGS STANDARD DETAIL BLOCKS
TM517	RECESSED PAVEMENT MARKERS
TM530	INTERSECTION PAVEMENT MARKINGS
TM560	ALIGNMENT LAYOUT: GENERAL
TM570	TRAFFIC DELINEATORS
TM571	TRAFFIC DELINEATORS STEEL POST DETAILS
TM800	TABLES, ABRUPT EDGE AND PCMS DETAILS
TM821	TEMPORARY SIGN SUPPORTS
TM822	TEMPORARY SIGN SUPPORTS
TM850	2-LANE, 2-WAY ROADWAYS
TM855	2-LANE, 2-WAY ROADWAYS

LOCATION MAP

NOT TO SCALE



Project Centerline	Canals
County Roads	Streams
Road Centerlines	Rivers
State Highways	City Limits



ROAD DEPARTMENT

TITLE:
COVER SHEET

SHEET NO:
1 of 16

DATE:
6/28/23

SCALE:
N.T.S.

DRAFTER: R. PINKSTON
REVIEWED BY: C. SMITH

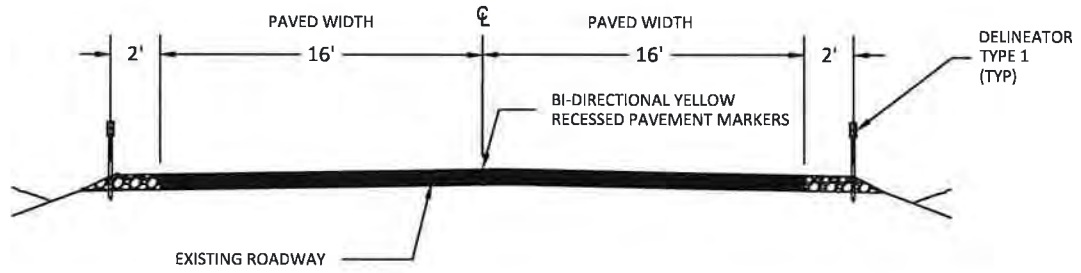

OLD BEND-REDMOND HIGHWAY

STA. 0+00 - STA. 26+90

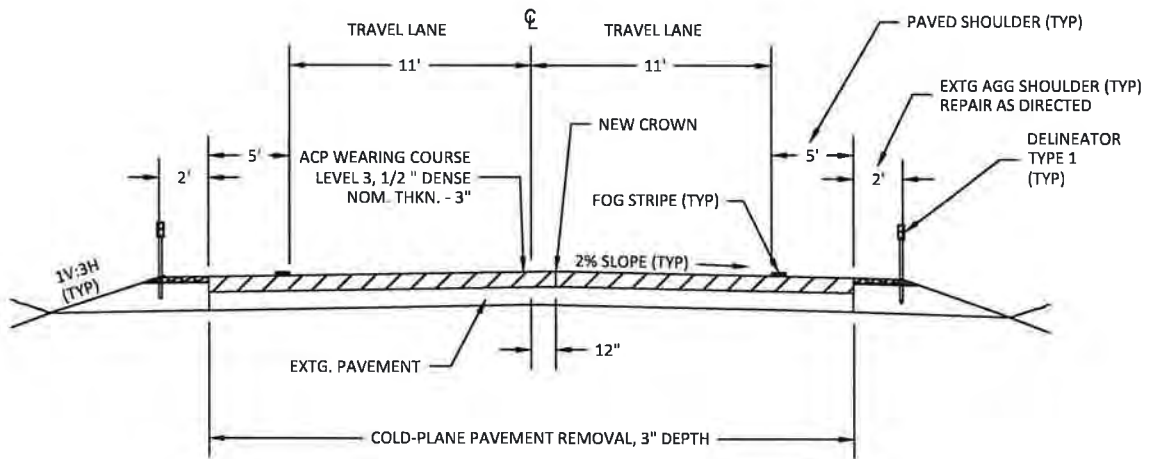

OLD BEND-REDMOND HIGHWAY

STA 26+90 - STA 150+69



RENEWS: JUNE 30, 2024



ROAD DEPARTMENT

TITLE: TYPICAL SECTION		PAGE NO: 2 OF 16
DATE: 6/28/23	SCALE: N.T.S.	APPROVED BY: C. SMITH

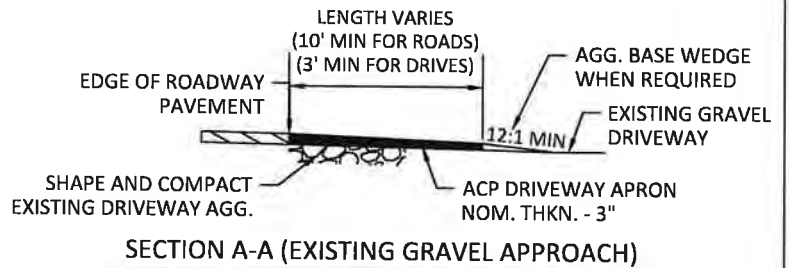
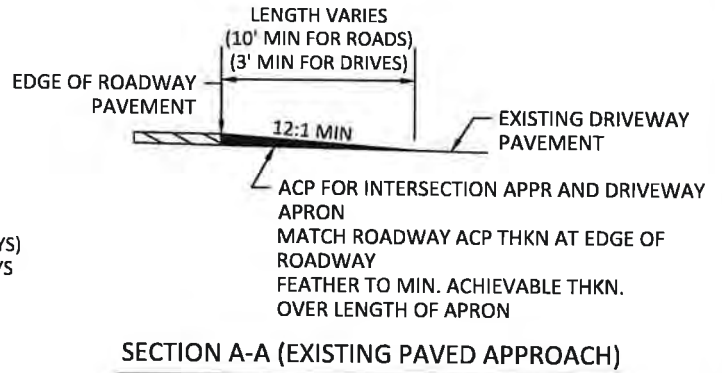
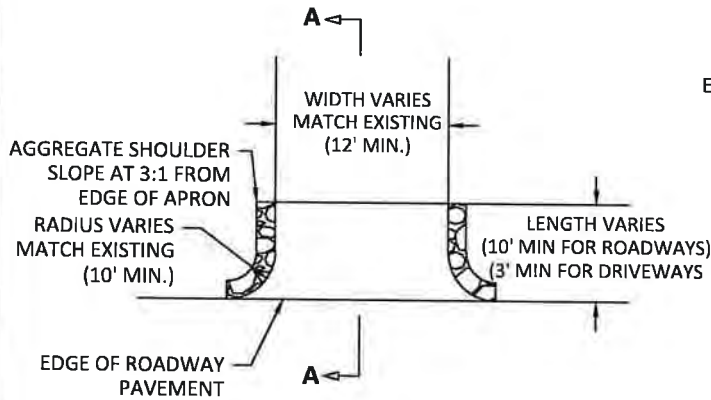
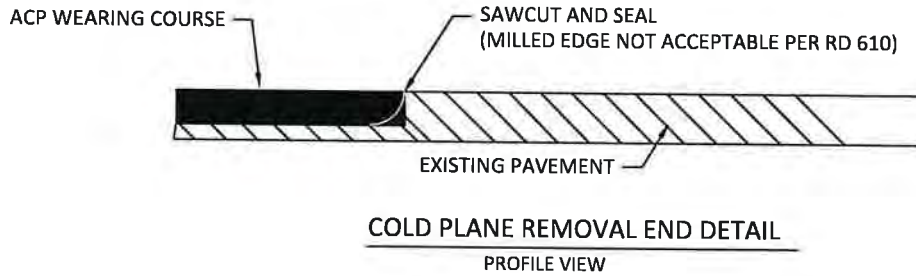
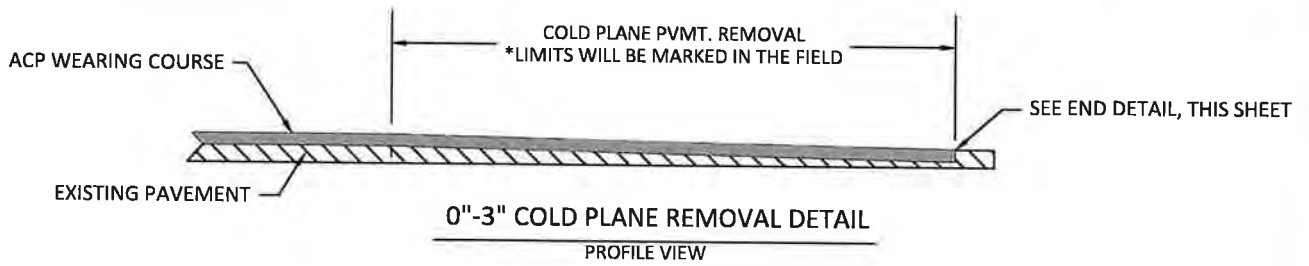

NOTE: DRIVEWAY APPROACHES ARE CONSIDERED MINOR APPROACHES UNLESS OTHERWISE APPROVED BY ENGINEER.

REGISTERED PROFESSIONAL ENGINEER
83448PE
OREGON
NOVEMBER 10, 2009
CODY C. SMITH
RENEWS: JUNE 30, 2024

DESCHUTES COUNTY

ROAD DEPARTMENT

TITLE: DETAILS		PAGE NO: 3 OF 16
DATE: 6/28/23	SCALE: N.T.S.	APPROVED BY: C. SMITH

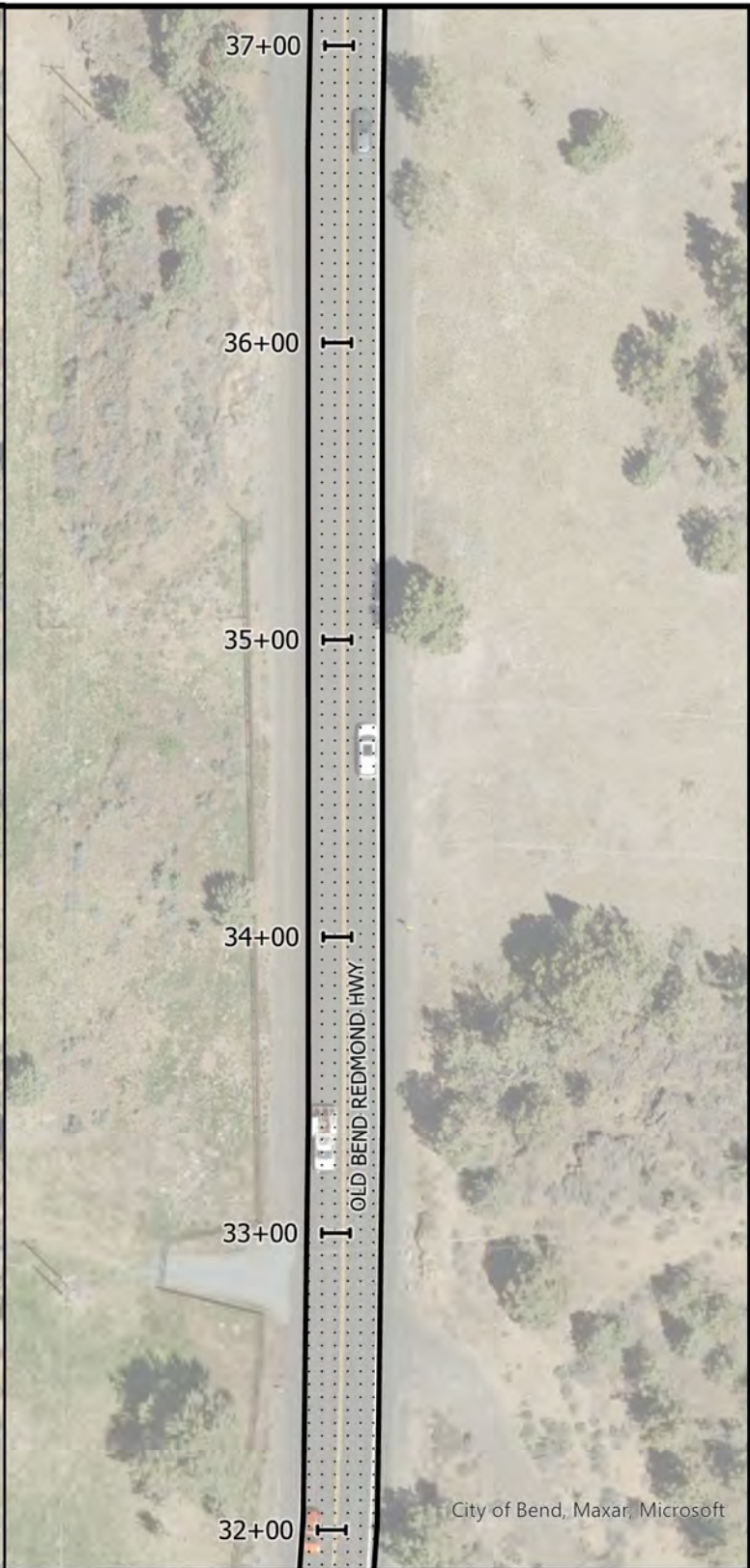
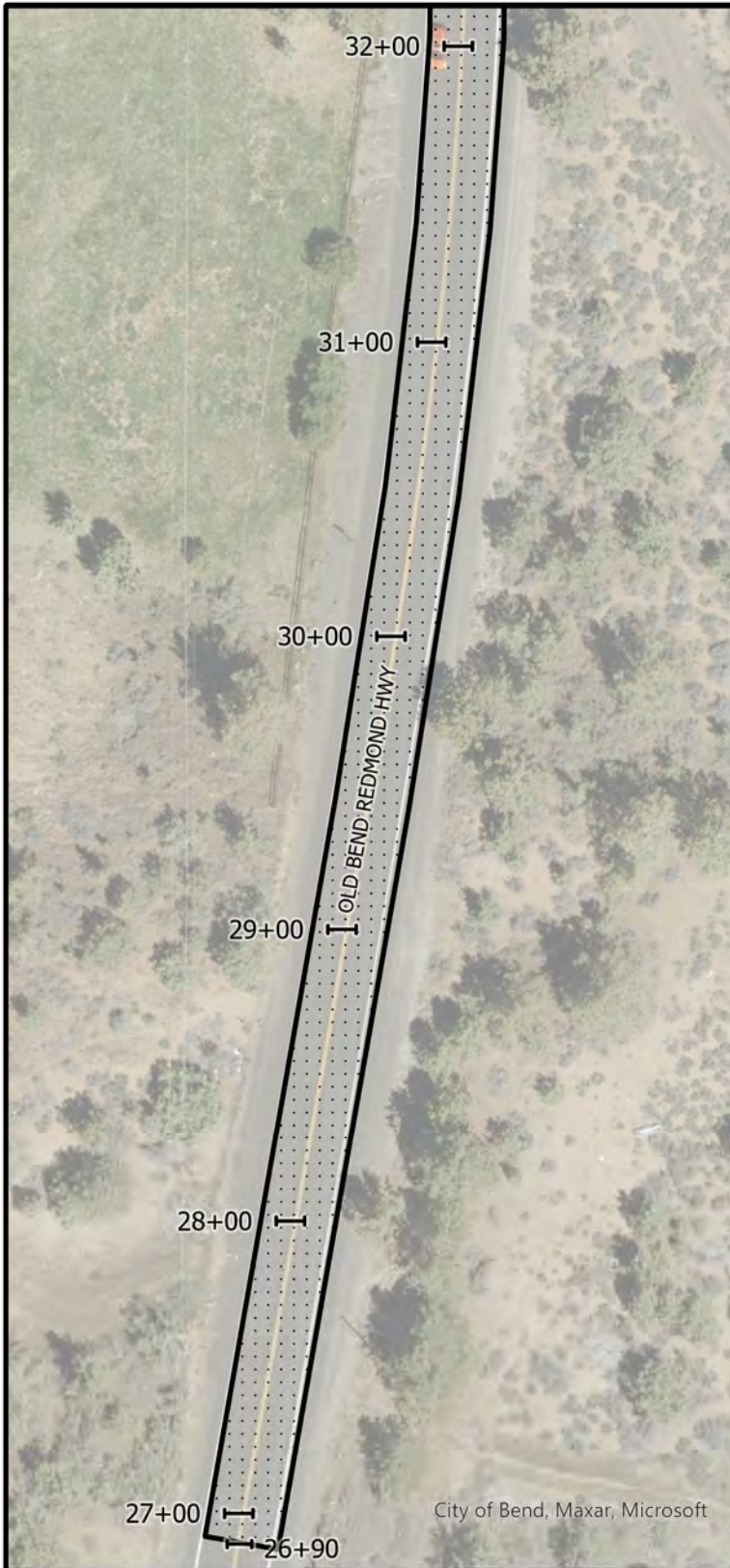

LEGEND

 3" INLAY, FULL WIDTH
(SEE TYPICAL SECTION, SHEET 2)



NOTES:

- 1.) INSTALL THERMOPLASTIC CENTERLINE STRIPING, (D R-40) PER TM 502
- 2.) INSTALL THERMOPLASTIC FOG LINE STRIPING (W) PER TM 500



ROAD DEPARTMENT

PLAN:
STA 26+90 to 37+00

SHEET NO:
4 of 16

DATE:
6/28/23

SCALE:
N.T.S.

DRAFTER: R. PINKSTON
REVIEWED BY: C. SMITH

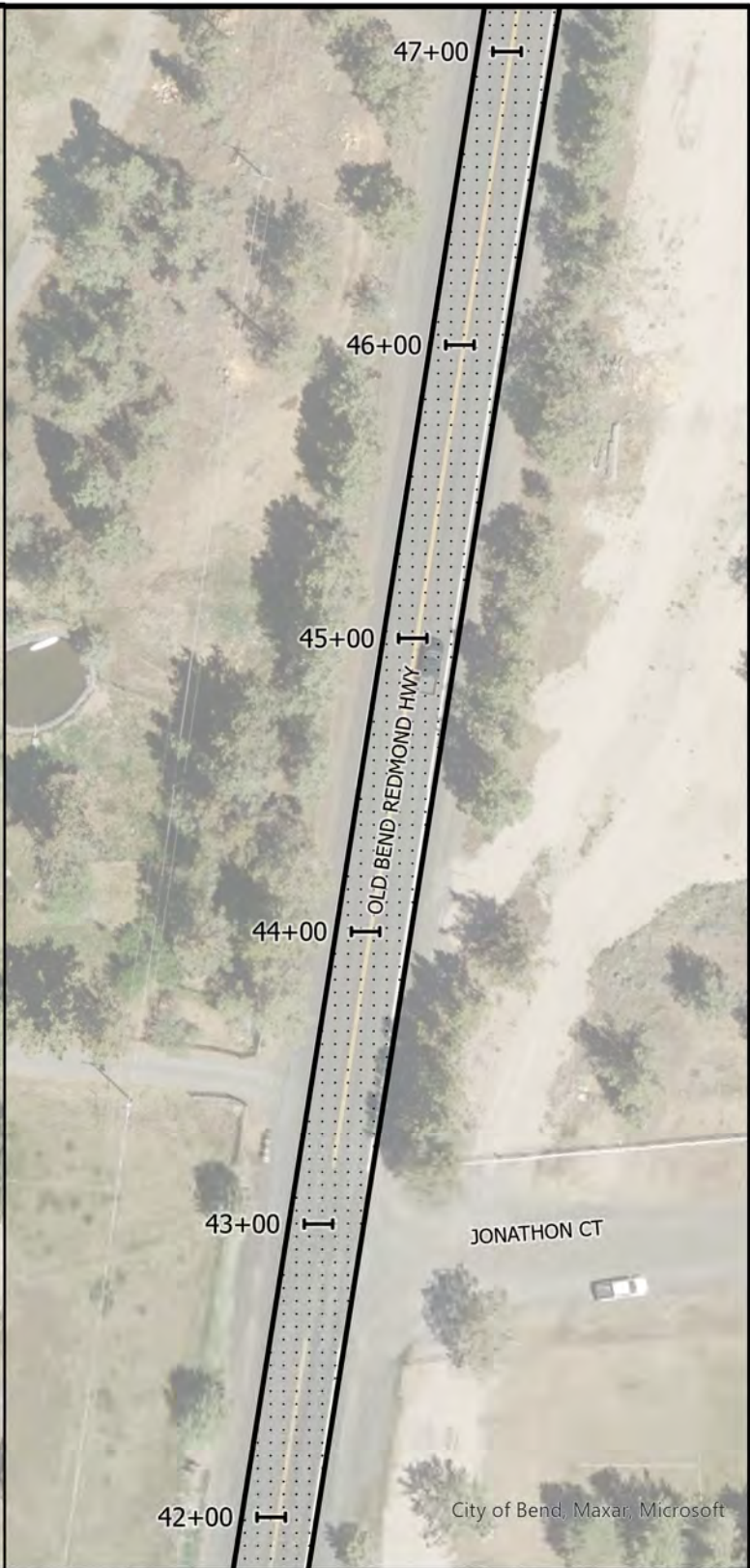
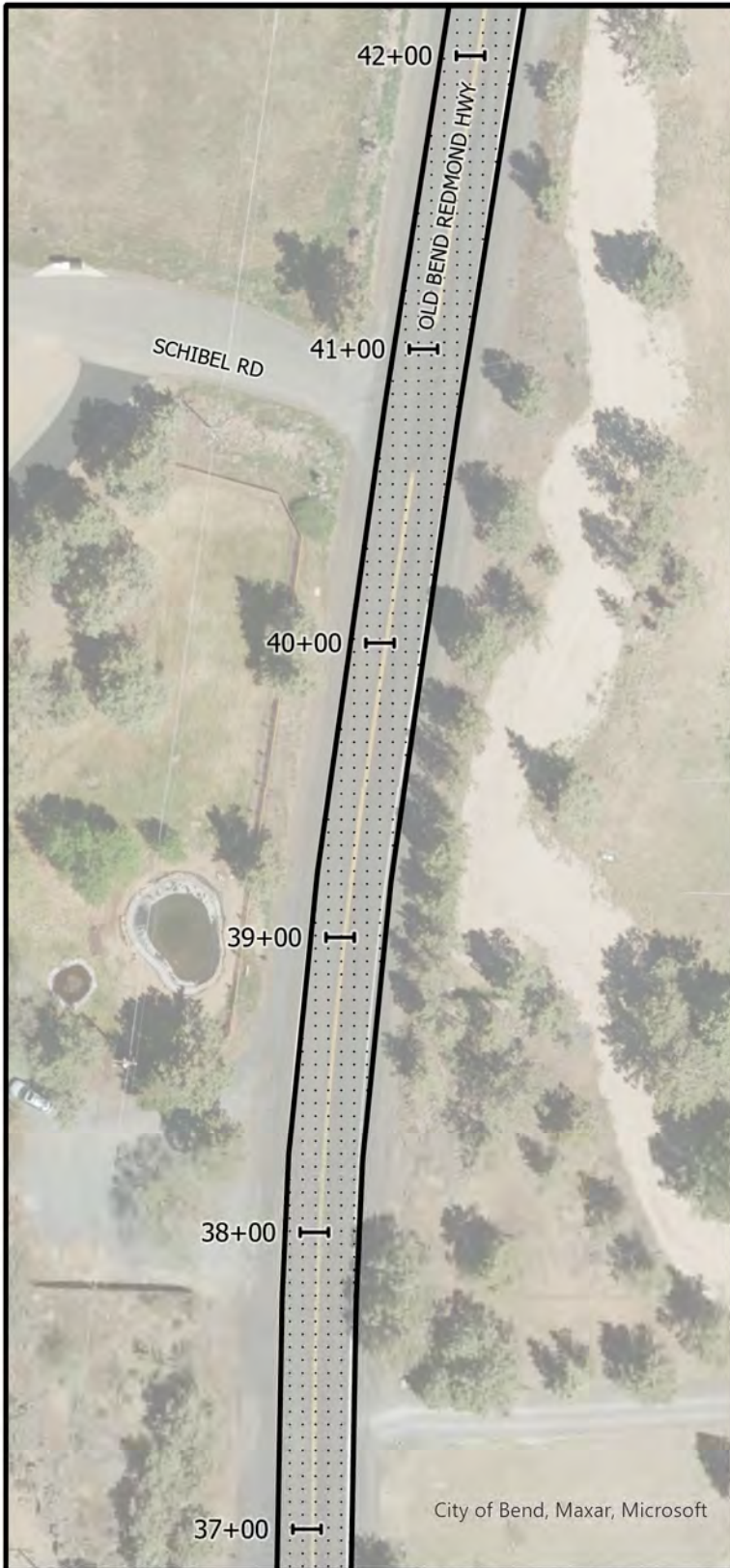

LEGEND

 3" INLAY, FULL WIDTH
(SEE TYPICAL SECTION, SHEET 2)



NOTES:

- 1.) INSTALL THERMOPLASTIC CENTERLINE STRIPING, (D R-40) PER TM 502
- 2.) INSTALL THERMOPLASTIC FOG LINE STRIPING (W) PER TM 500



ROAD DEPARTMENT

PLAN:
STA 37+00 to 47+00

SHEET NO:
5 of 16

DATE:
6/28/23

SCALE:
N.T.S.

DRAFTER: R. PINKSTON
REVIEWED BY: C. SMITH

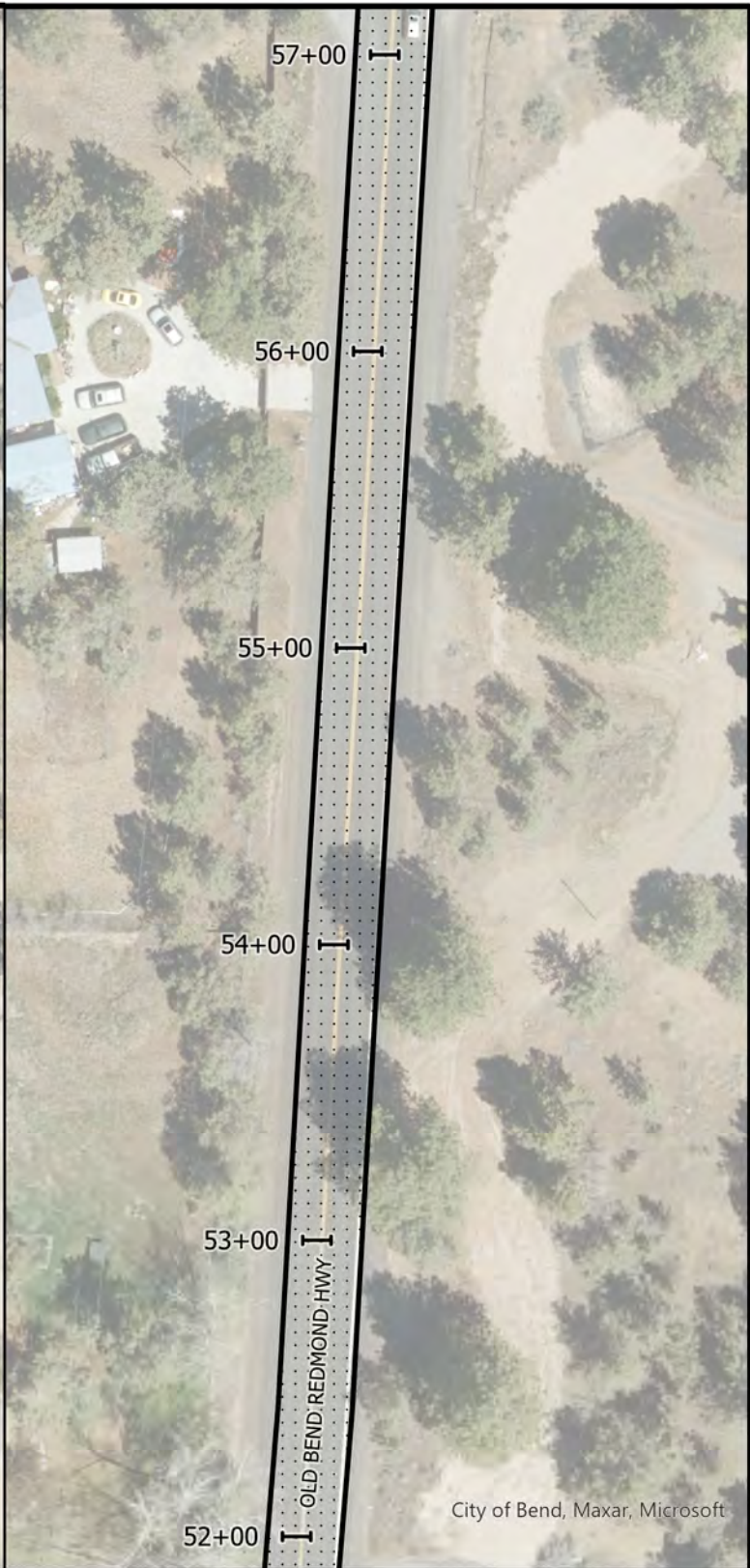
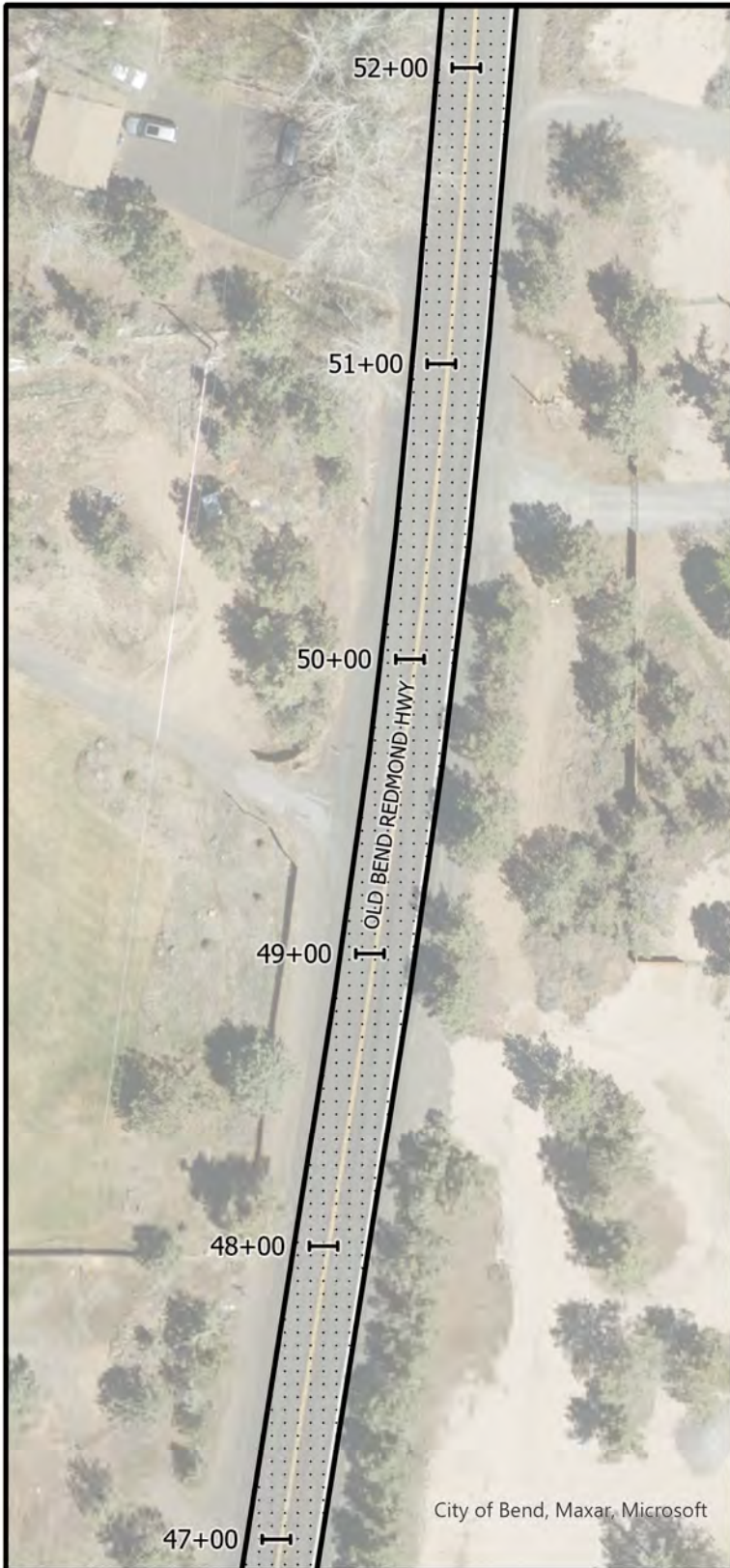

LEGEND

 3" INLAY, FULL WIDTH
(SEE TYPICAL SECTION, SHEET 2)



NOTES:

- 1.) INSTALL THERMOPLASTIC CENTERLINE STRIPING, (D R-40) PER TM 502
- 2.) INSTALL THERMOPLASTIC FOG LINE STRIPING (W) PER TM 500



ROAD DEPARTMENT

PLAN:
STA 47+00 to 57+00

SHEET NO:
6 of 16

DATE:
6/28/23

SCALE:
N.T.S.

DRAFTER: R. PINKSTON
REVIEWED BY: C. SMITH

City of Bend, Maxar, Microsoft

City of Bend, Maxar, Microsoft



LEGEND

 3" INLAY, FULL WIDTH
(SEE TYPICAL SECTION, SHEET 2)



NOTES:

- 1.) INSTALL THERMOPLASTIC CENTERLINE STRIPING, (D R-40) PER TM 502
- 2.) INSTALL THERMOPLASTIC FOG LINE STRIPING (W) PER TM 500



ROAD DEPARTMENT

PLAN:
STA 57+00 to 67+00

SHEET NO:
7 of 16

DATE:
6/28/23

SCALE:
N.T.S.

DRAFTER: R. PINKSTON
REVIEWED BY: C. SMITH

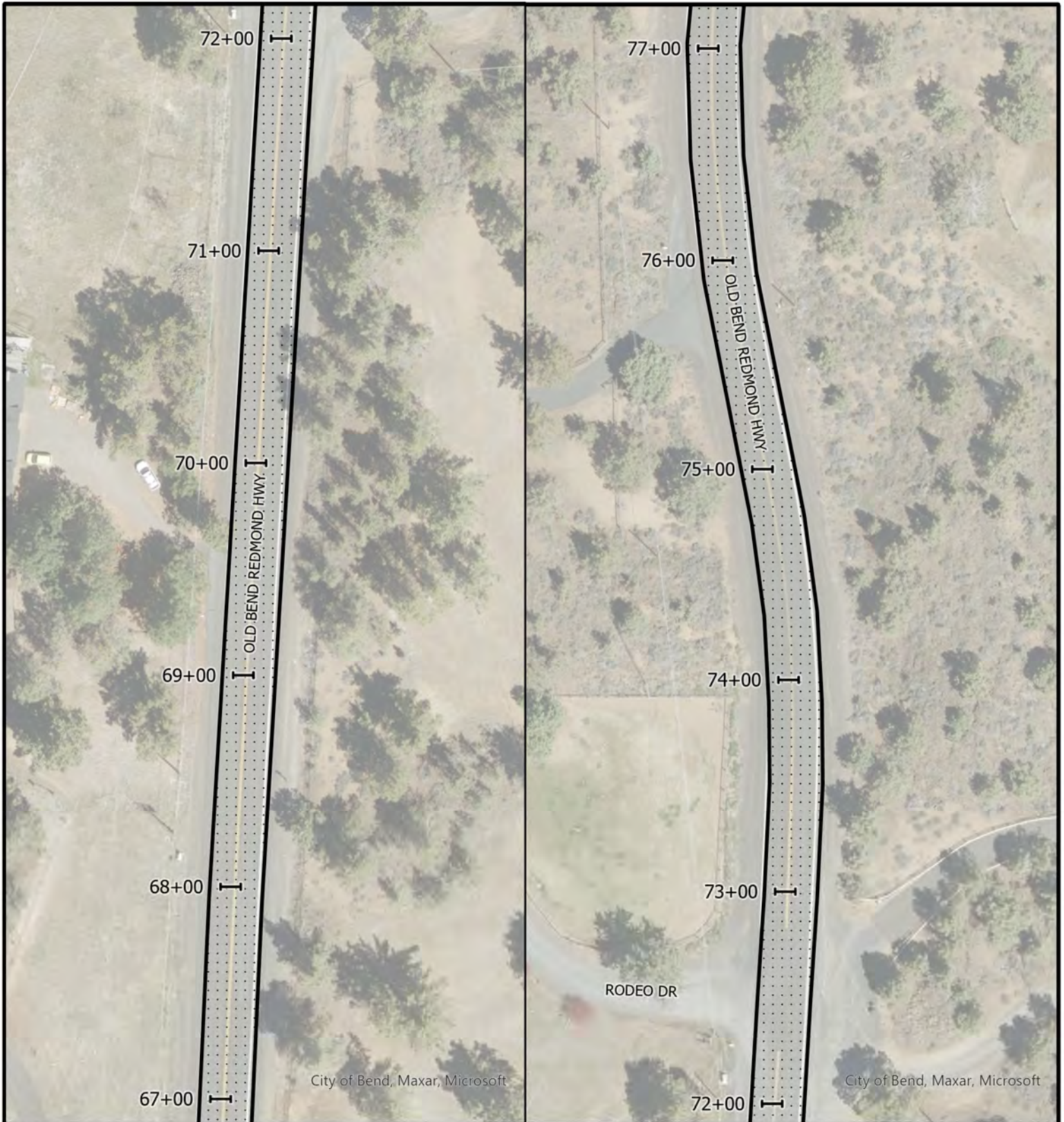

LEGEND

 3" INLAY, FULL WIDTH
(SEE TYPICAL SECTION, SHEET 2)



NOTES:

- 1.) INSTALL THERMOPLASTIC CENTERLINE STRIPING, (D R-40) PER TM 502
- 2.) INSTALL THERMOPLASTIC FOG LINE STRIPING (W) PER TM 500



ROAD DEPARTMENT

PLAN:
STA 67+00 to 77+00

SHEET NO:
8 of 16

DATE:
6/28/23

SCALE:
N.T.S.

DRAFTER: R. PINKSTON
REVIEWED BY: C. SMITH

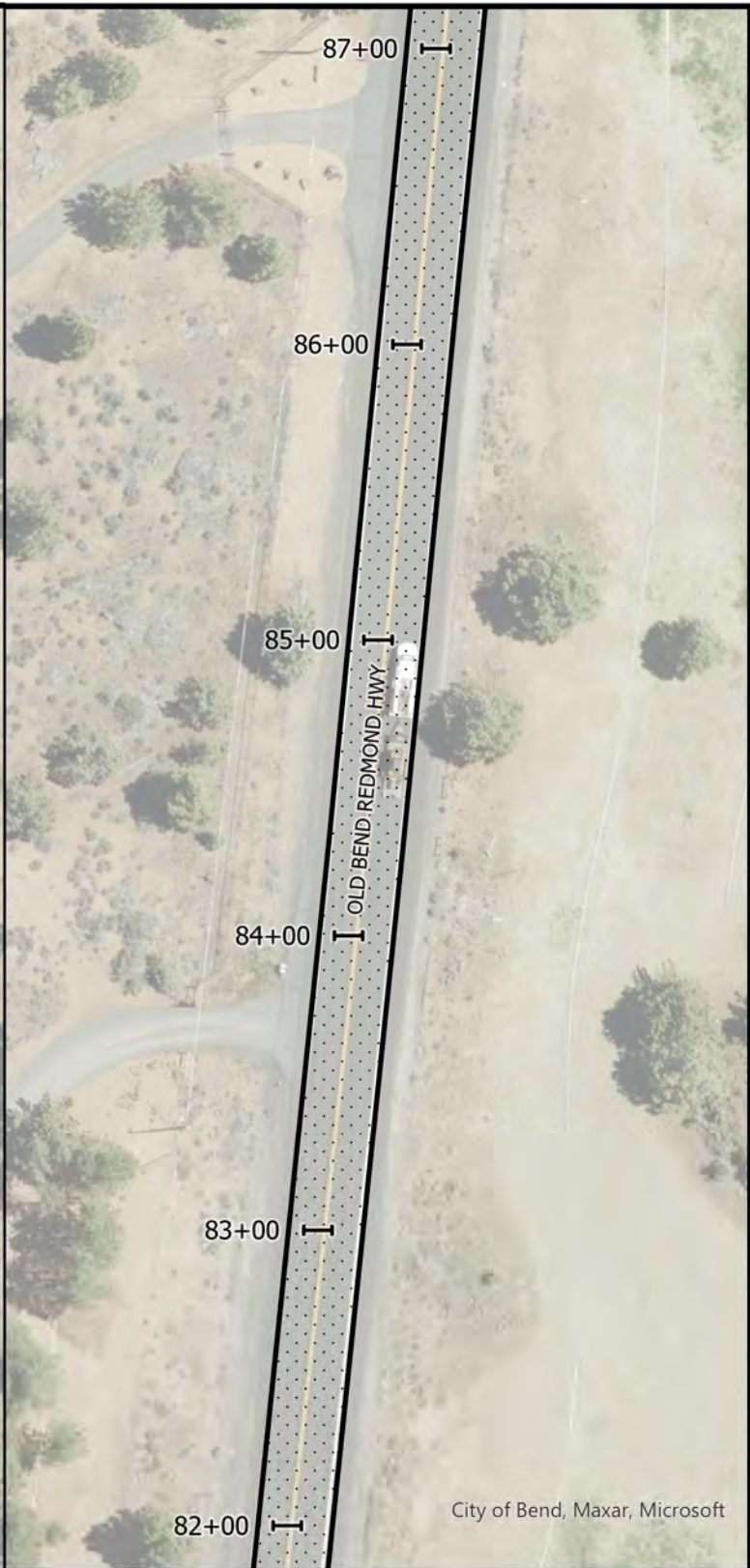
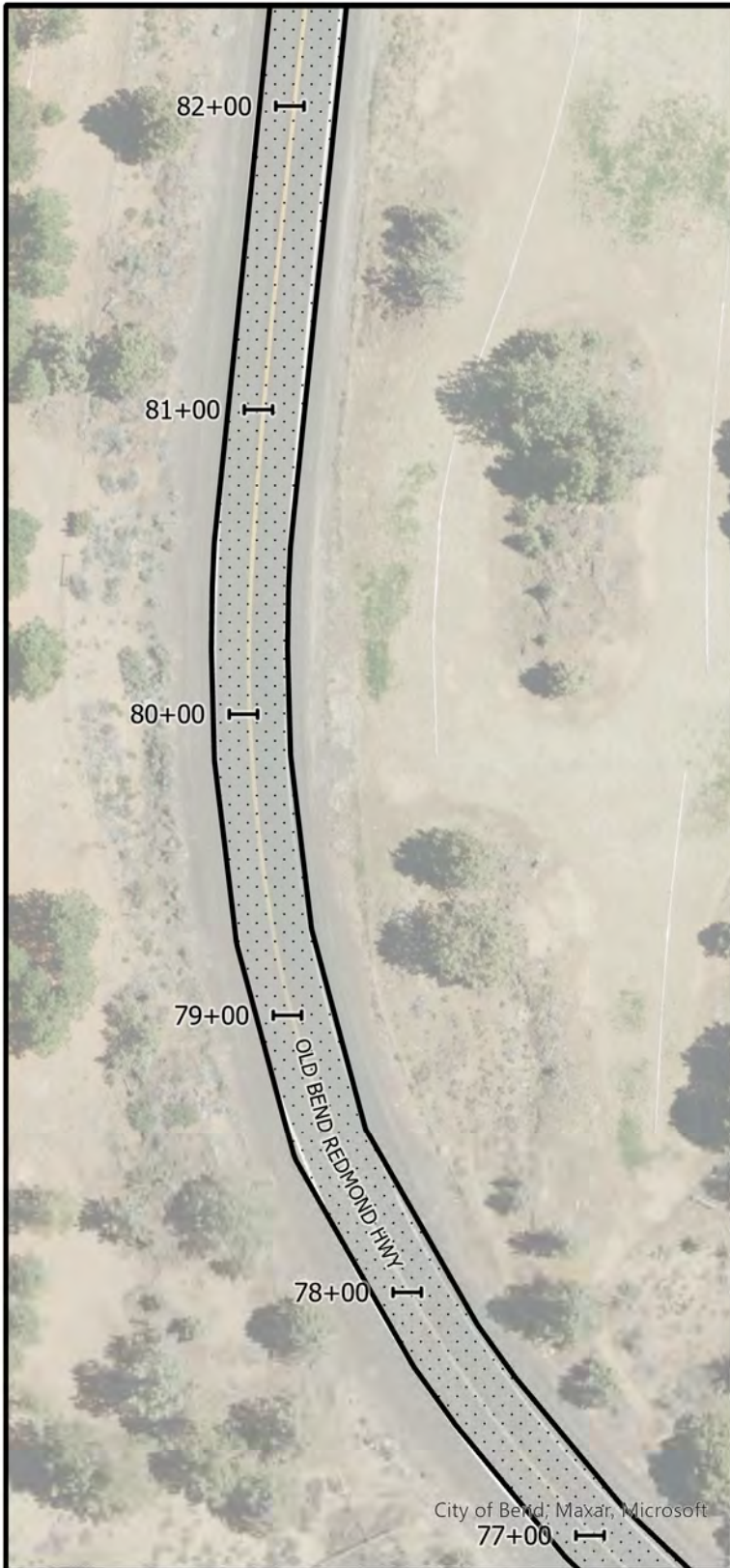

LEGEND

 3" INLAY, FULL WIDTH
(SEE TYPICAL SECTION, SHEET 2)



NOTES:

- 1.) INSTALL THERMOPLASTIC CENTERLINE STRIPING, (D R-40) PER TM 502
- 2.) INSTALL THERMOPLASTIC FOG LINE STRIPING (W) PER TM 500

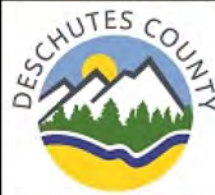

ROAD DEPARTMENT

PLAN:
STA 77+00 to 87+00

SHEET NO:
9 of 16

DATE:
6/28/23

SCALE:
N.T.S.

DRAFTER: R. PINKSTON
REVIEWED BY: C. SMITH

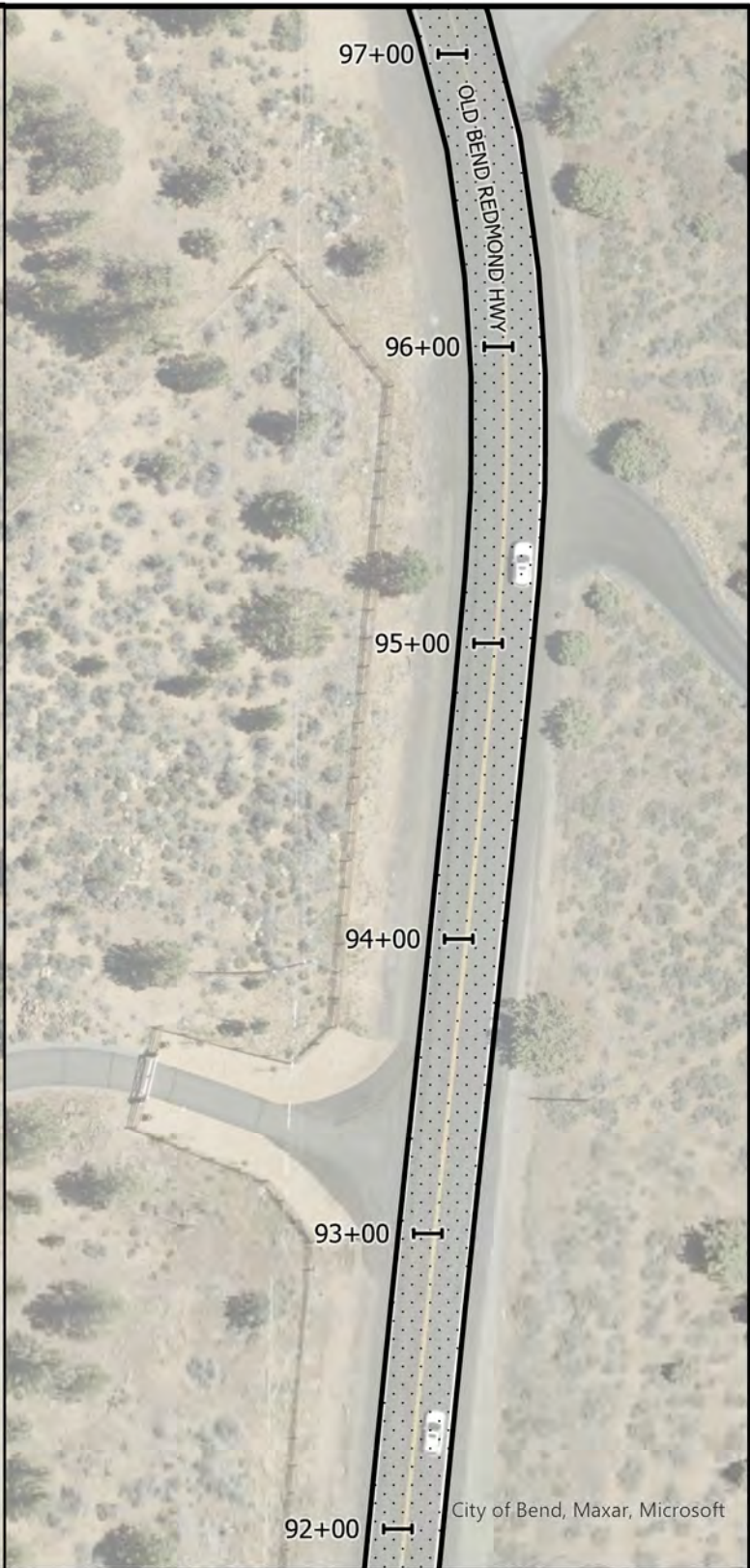
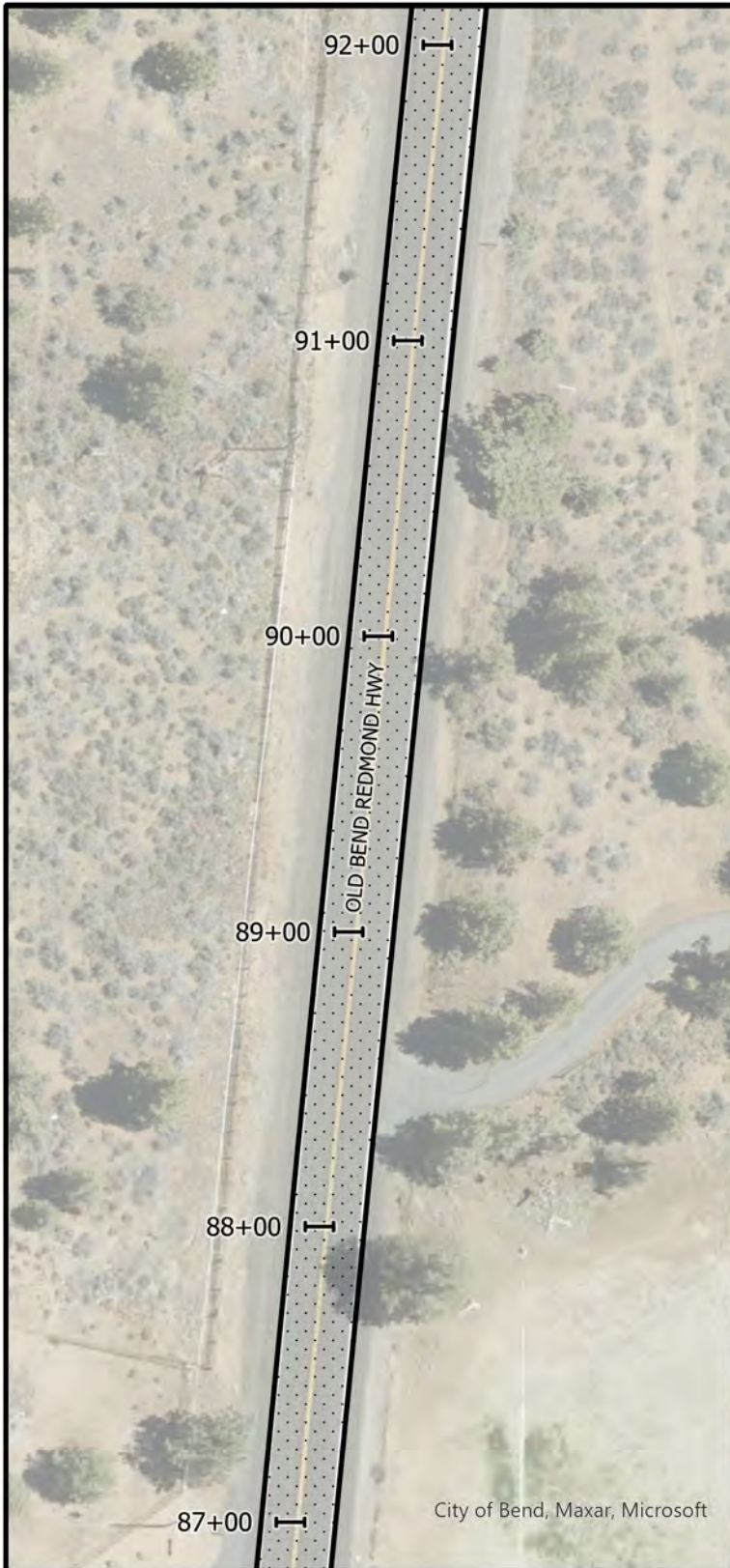

LEGEND

 3" INLAY, FULL WIDTH
(SEE TYPICAL SECTION, SHEET 2)



NOTES:

- 1.) INSTALL THERMOPLASTIC CENTERLINE STRIPING, (D R-40) PER TM 502
- 2.) INSTALL THERMOPLASTIC FOG LINE STRIPING (W) PER TM 500



ROAD DEPARTMENT

PLAN:
STA 87+00 to 97+00

SHEET NO:
10 of 16

DATE:
6/28/23

SCALE:
N.T.S.

DRAFTER: R. PINKSTON
REVIEWED BY: C. SMITH

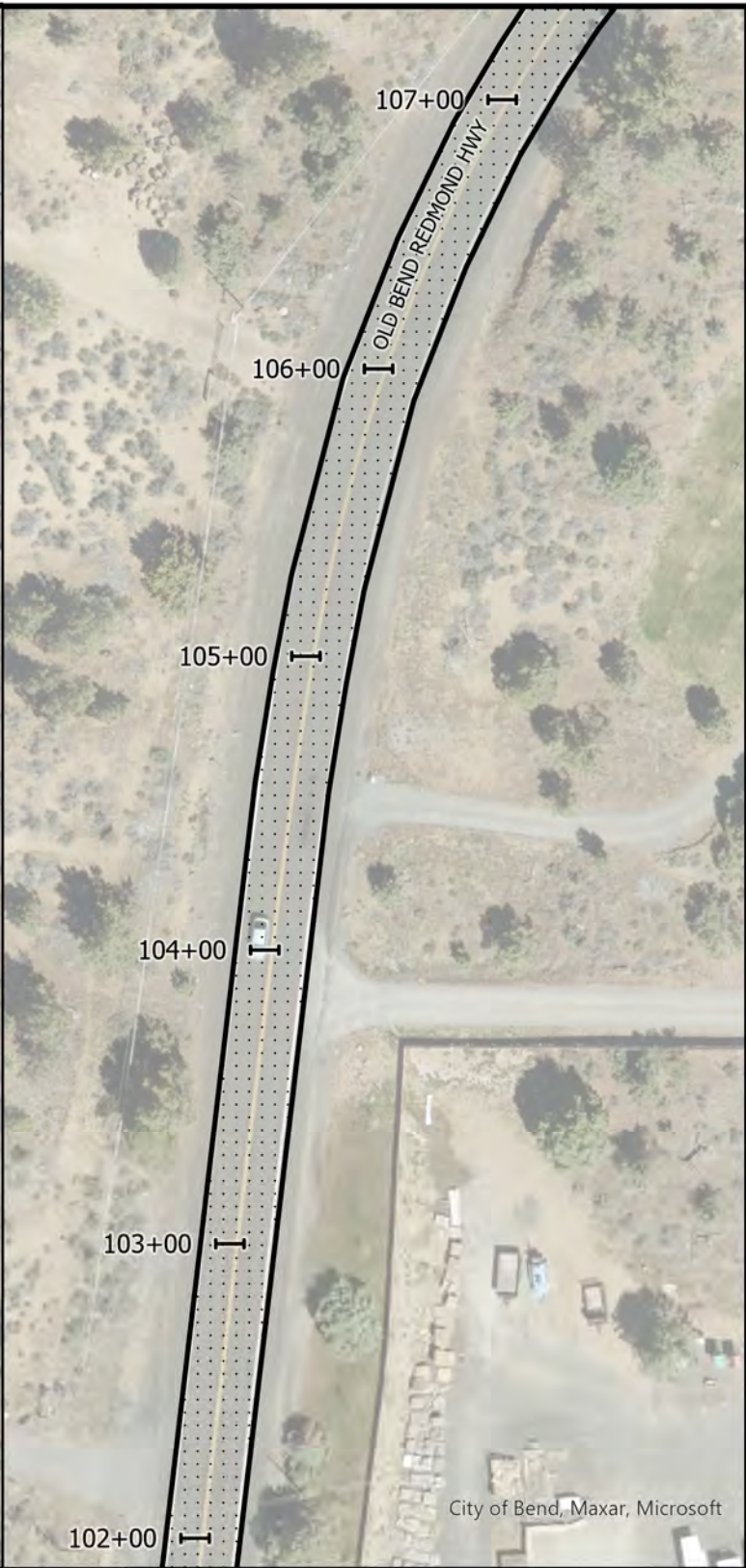
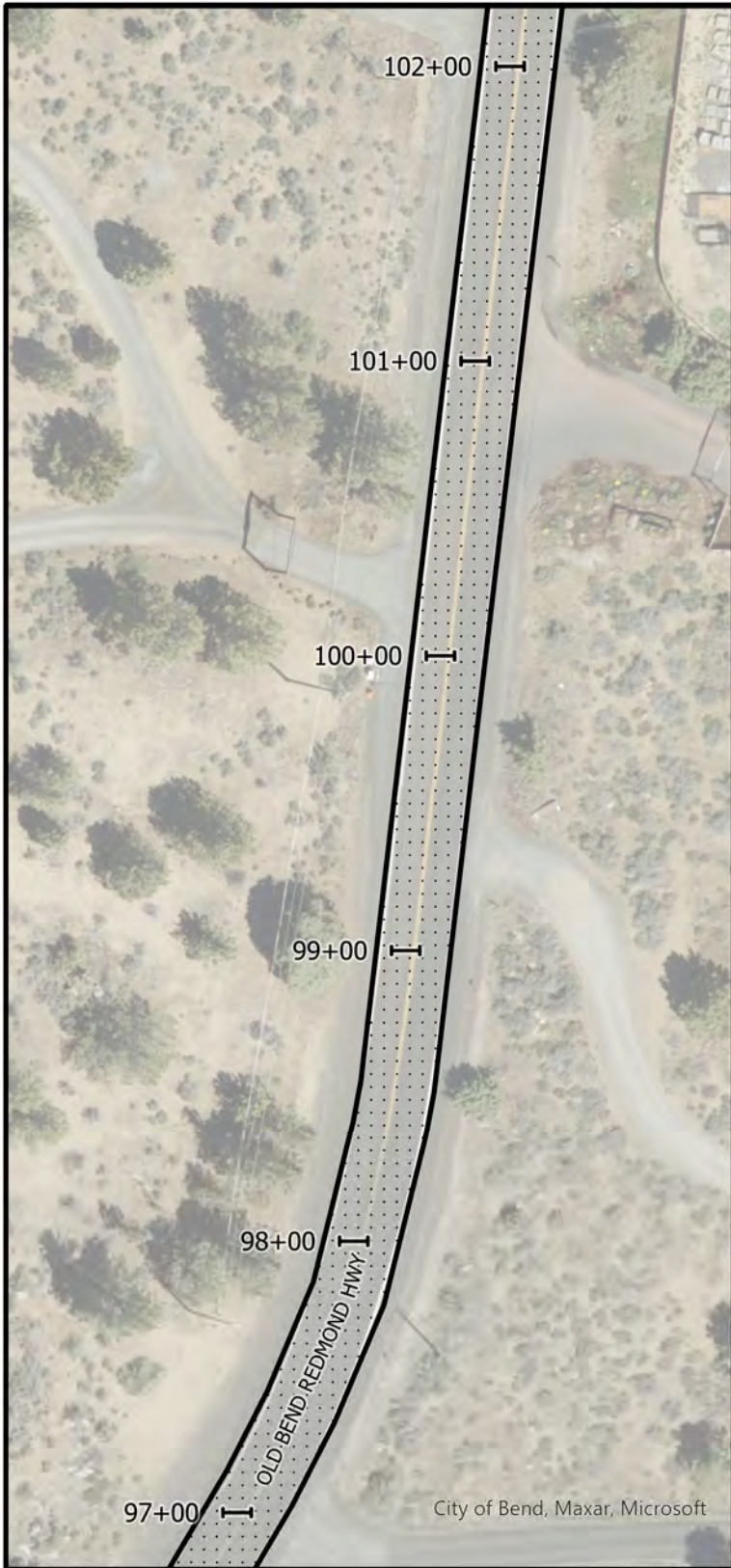

LEGEND

 3" INLAY, FULL WIDTH
(SEE TYPICAL SECTION, SHEET 2)



NOTES:

- 1.) INSTALL THERMOPLASTIC CENTERLINE STRIPING, (D R-40) PER TM 502
- 2.) INSTALL THERMOPLASTIC FOG LINE STRIPING (W) PER TM 500



ROAD DEPARTMENT

PLAN:
STA 97+00 to 107+00

SHEET NO:
11 of 16

DATE:
6/28/23

SCALE:
N.T.S.

DRAFTER: R. PINKSTON
REVIEWED BY: C. SMITH

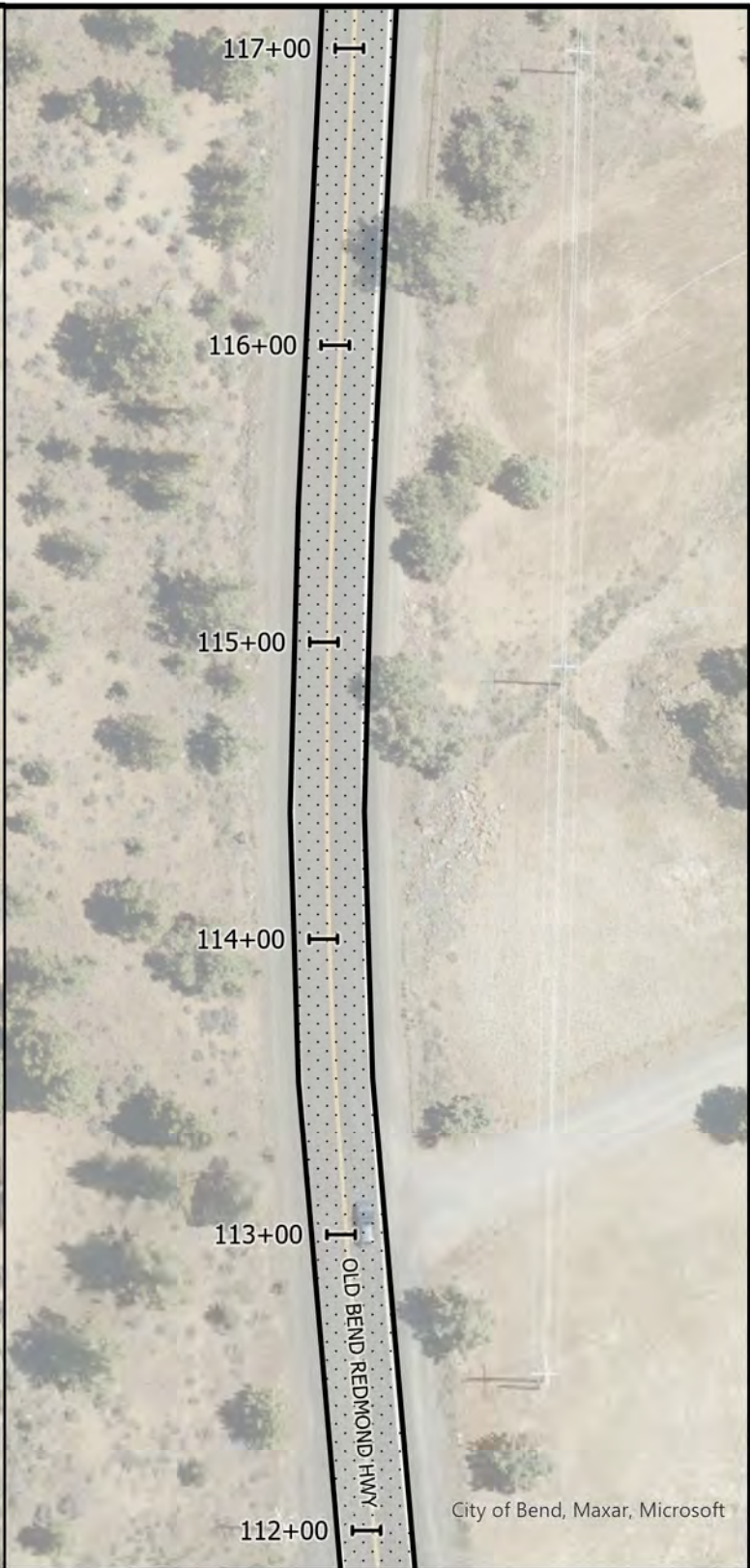
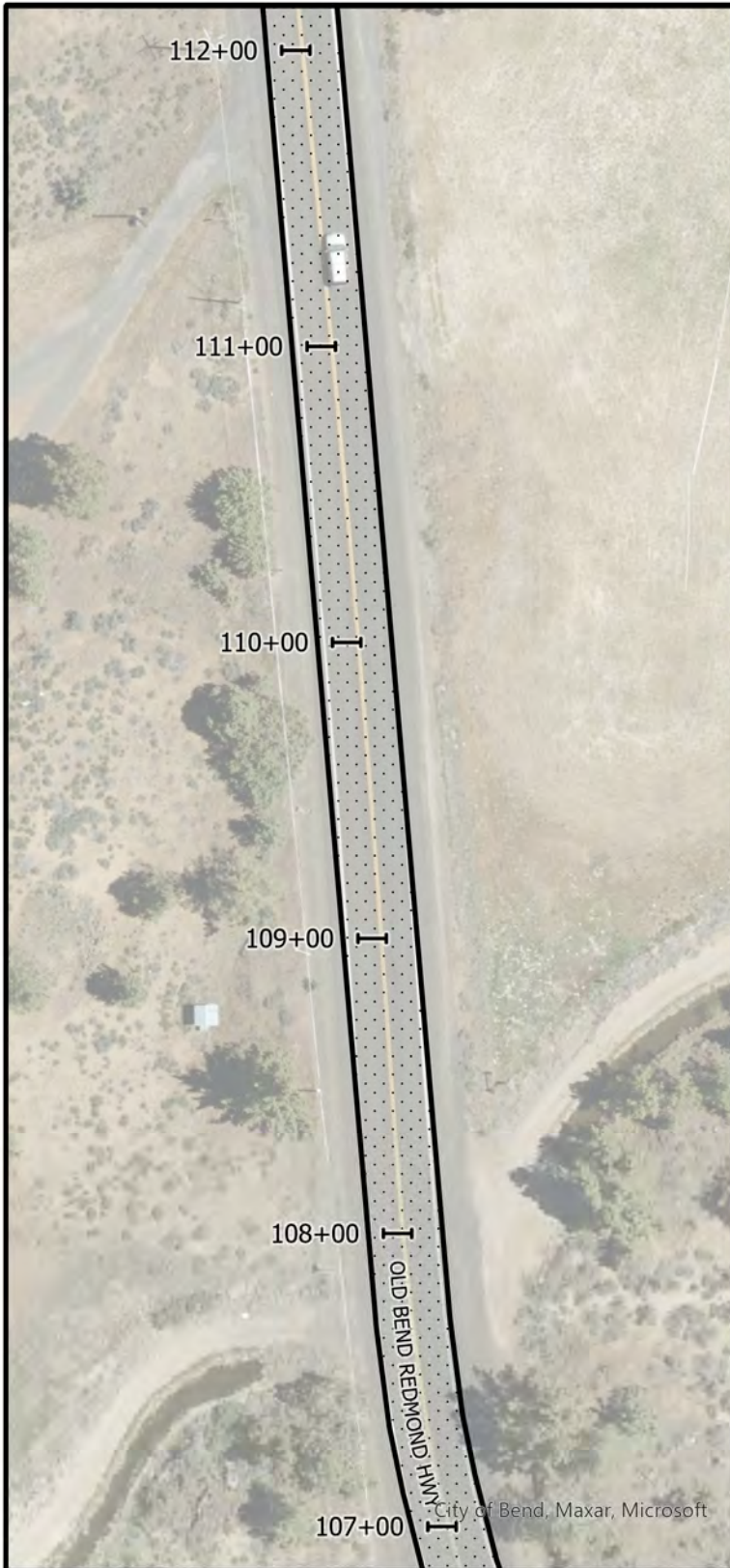

LEGEND

 3" INLAY, FULL WIDTH
(SEE TYPICAL SECTION, SHEET 2)



NOTES:

- 1.) INSTALL THERMOPLASTIC CENTERLINE STRIPING, (D R-40) PER TM 502
- 2.) INSTALL THERMOPLASTIC FOG LINE STRIPING (W) PER TM 500



ROAD DEPARTMENT

PLAN:
STA 107+00 to 117+00

SHEET NO:
12 of 16

DATE:
6/28/23

SCALE:
N.T.S.

DRAFTER: R. PINKSTON
REVIEWED BY: C. SMITH



LEGEND

 3" INLAY, FULL WIDTH
(SEE TYPICAL SECTION, SHEET 2)



NOTES:

- 1.) INSTALL THERMOPLASTIC CENTERLINE STRIPING, (D R-40) PER TM 502
- 2.) INSTALL THERMOPLASTIC FOG LINE STRIPING (W) PER TM 500



ROAD DEPARTMENT

PLAN:
STA 117+00 to 127+00

SHEET NO:
13 of 16

DATE:
6/28/23

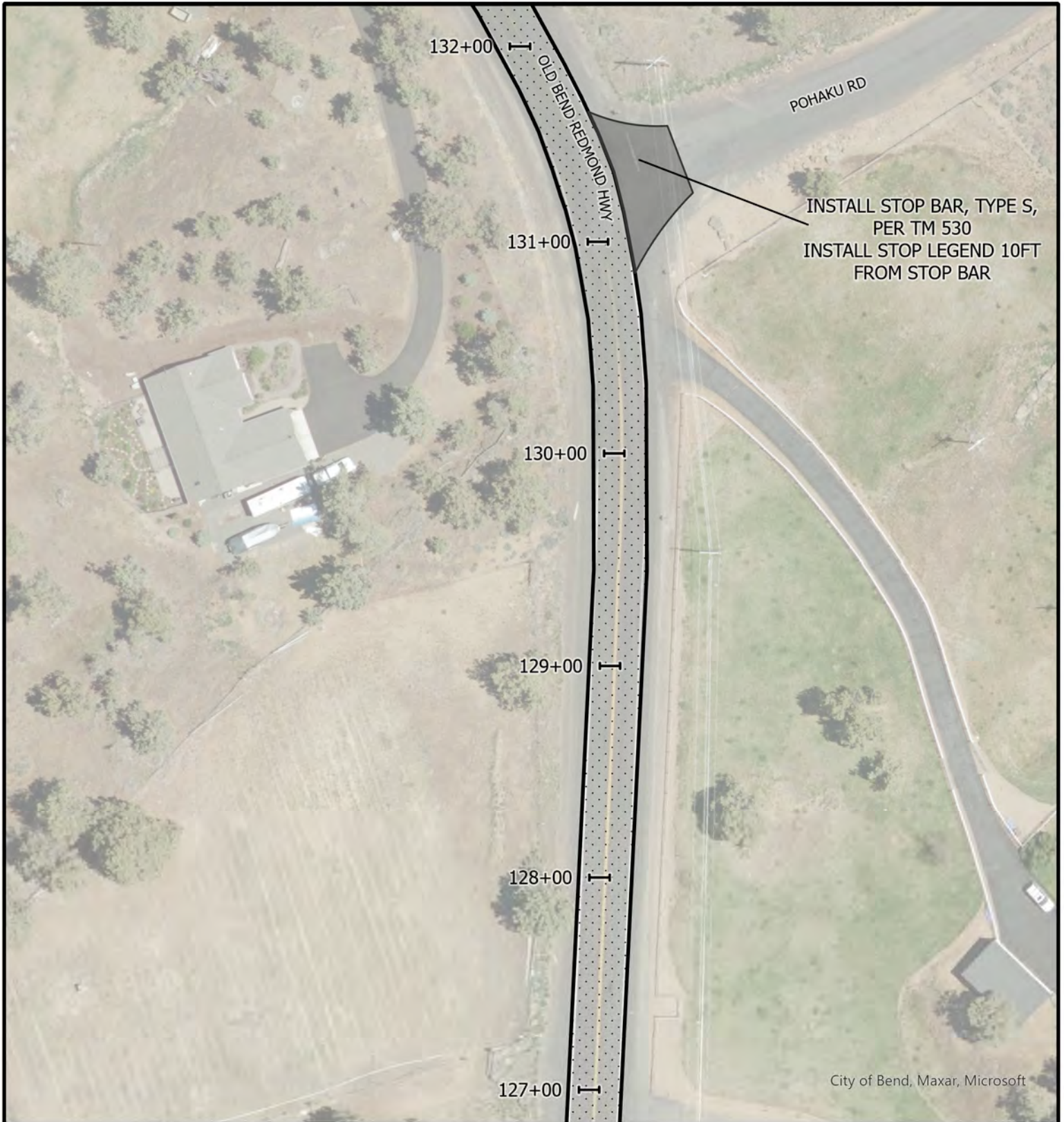

SCALE:
N.T.S.

DRAFTER: R. PINKSTON
REVIEWED BY: C. SMITH



City of Bend, Maxar, Microsoft

LEGEND

-  3" INLAY, FULL WIDTH
(SEE TYPICAL SECTION, SHEET 2)
-  ASPHALT
APPROACH



NOTES:

- 1.) INSTALL THERMOPLASTIC CENTERLINE STRIPING, (D R-40) PER TM 502
- 2.) INSTALL THERMOPLASTIC FOG LINE STRIPING (W) PER TM 500



ROAD DEPARTMENT

PLAN: STA 127+00 to 132+00		SHEET NO: 14 of 16
DATE: 6/28/23	SCALE: N.T.S.	DRAFTER: R. PINKSTON REVIEWED BY: C. SMITH

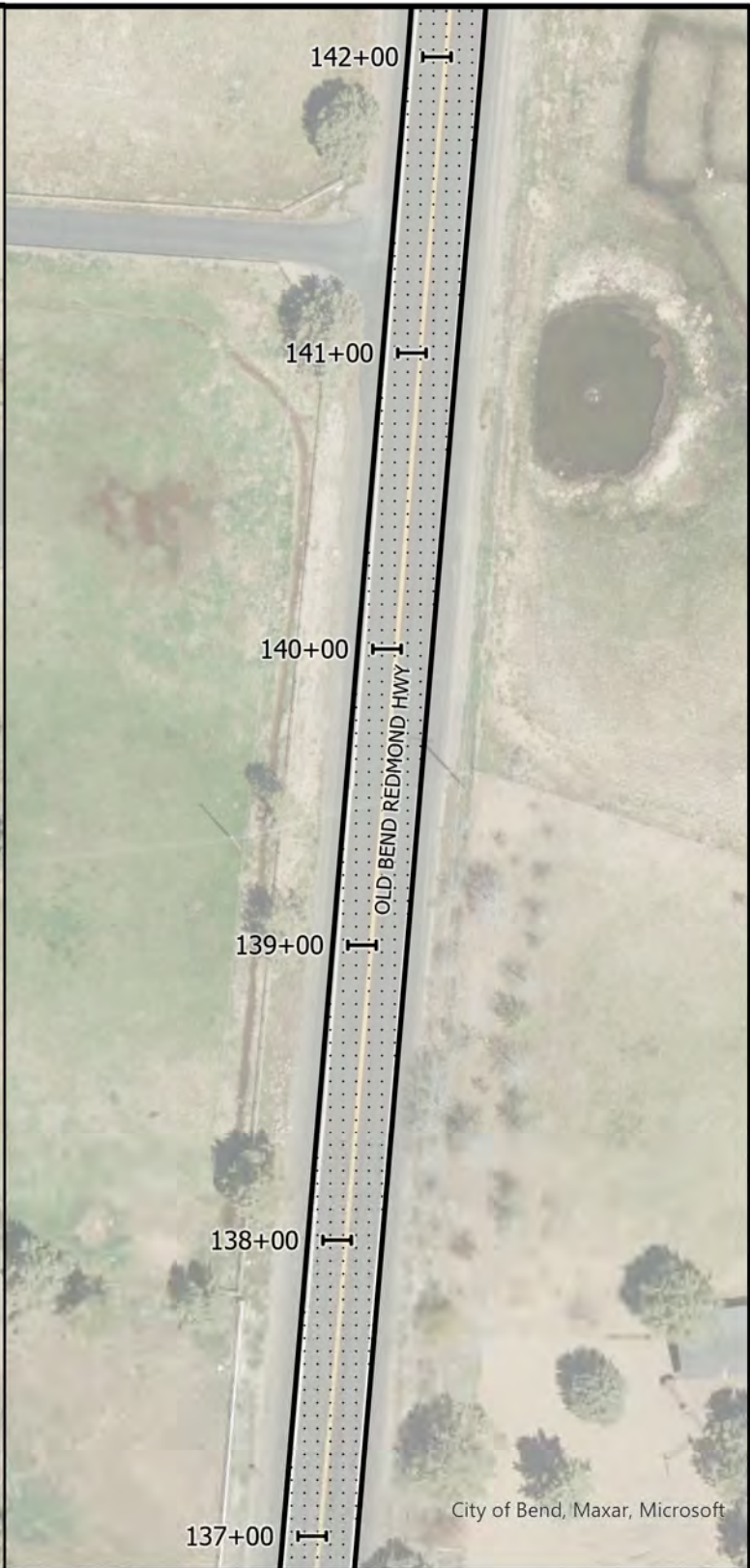
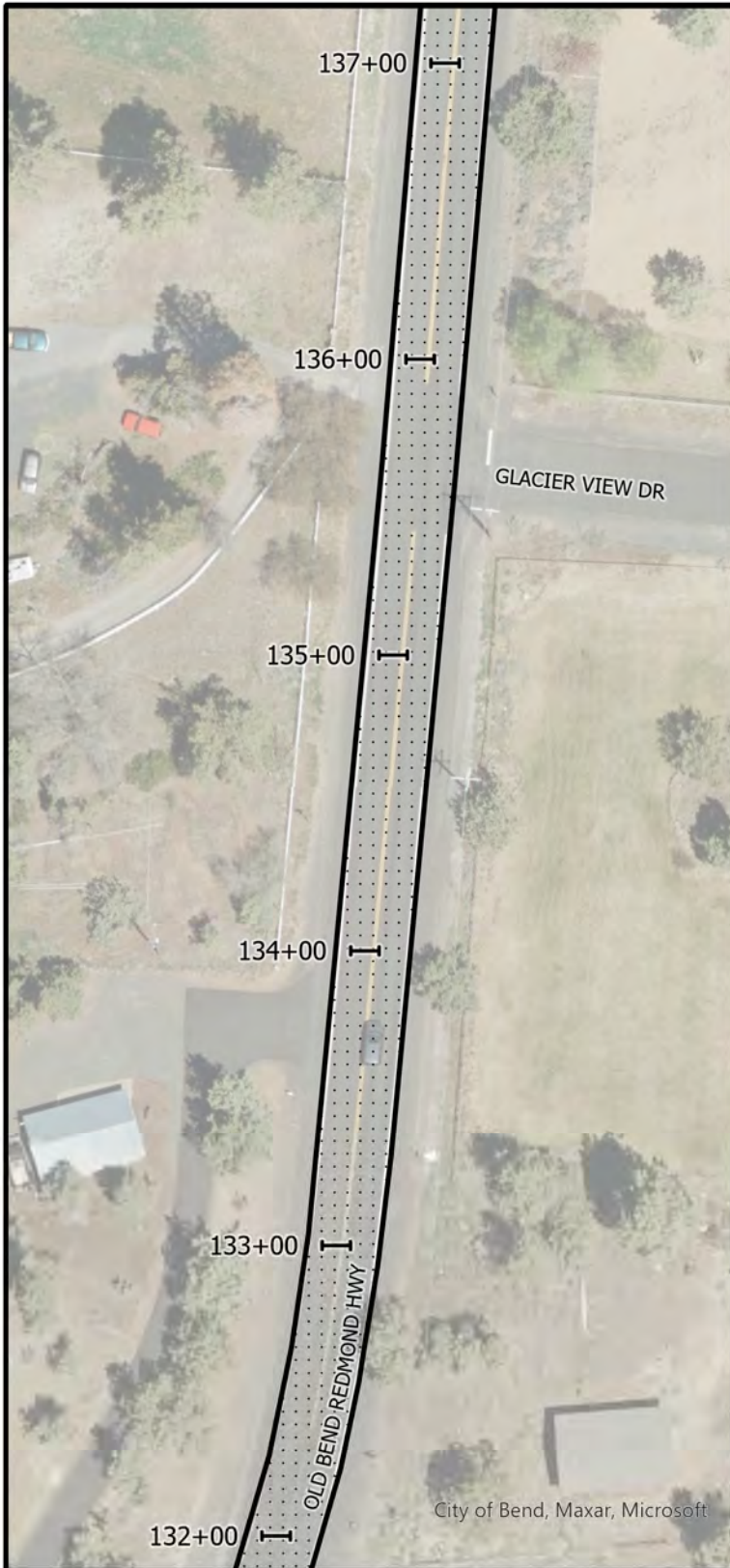

LEGEND

 3" INLAY, FULL WIDTH
(SEE TYPICAL SECTION, SHEET 2)

 APPROACH



NOTES:

1.) INSTALL THERMOPLASTIC CENTERLINE STRIPING, (D R-40) PER TM 502

2.) INSTALL THERMOPLASTIC FOG LINE STRIPING (W) PER TM 500



ROAD DEPARTMENT

PLAN:
STA 132+00 to 142+00

SHEET NO:
15 of 16

DATE:
6/28/23

SCALE:
N.T.S.

DRAFTER: R. PINKSTON
REVIEWED BY: C. SMITH

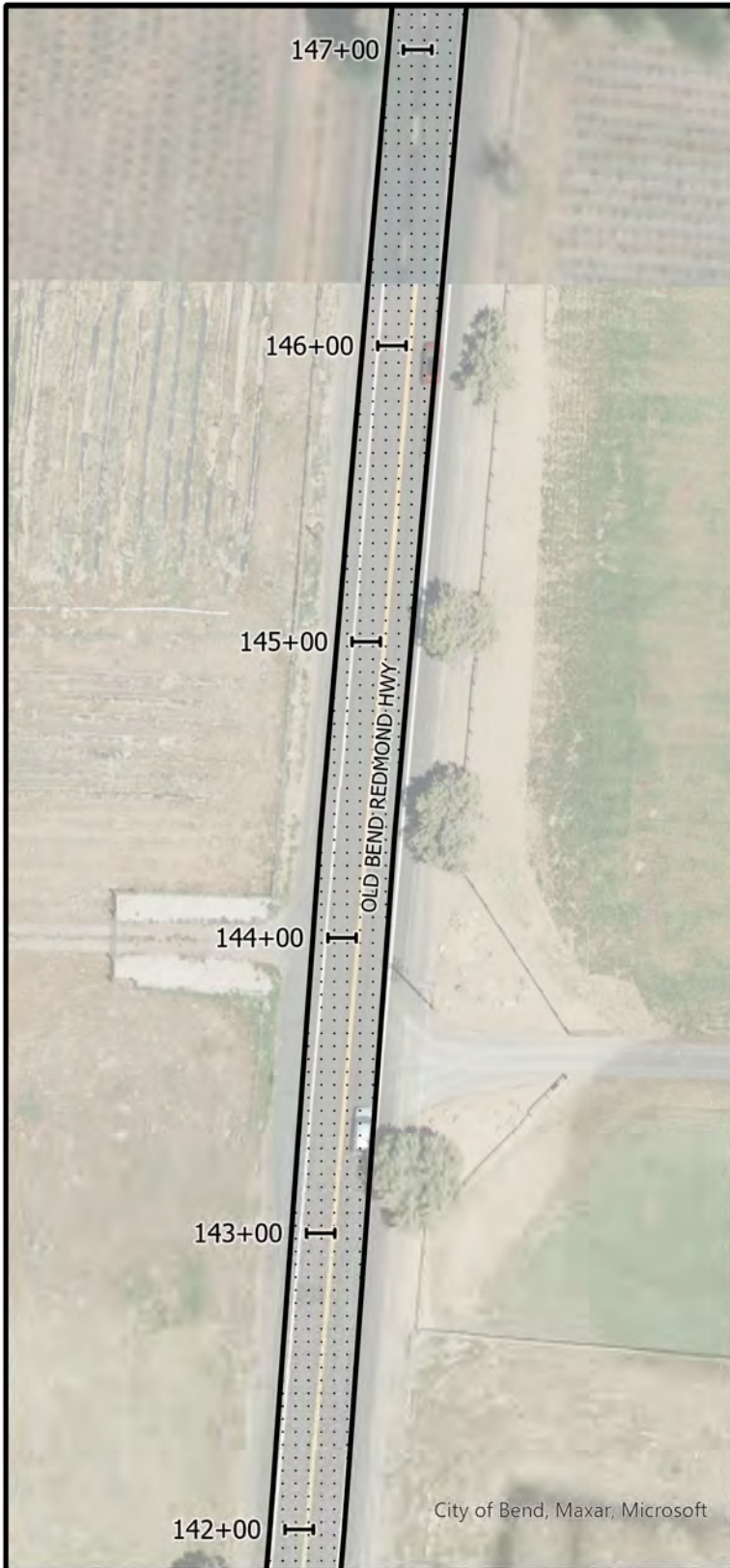

LEGEND

 3" INLAY, FULL WIDTH
(SEE TYPICAL SECTION, SHEET 2)



NOTES:

- 1.) INSTALL THERMOPLASTIC CENTERLINE STRIPING, (D R-40) PER TM 502
- 2.) INSTALL THERMOPLASTIC FOG LINE STRIPING (W) PER TM 500



ROAD DEPARTMENT

PLAN:
STA 142+00 to END

SHEET NO:
16 of 16

DATE:
6/28/23

SCALE:
N.T.S.

DRAFTER: R. PINKSTON
REVIEWED BY: C. SMITH

RD610.dgn 20-JUL-2020

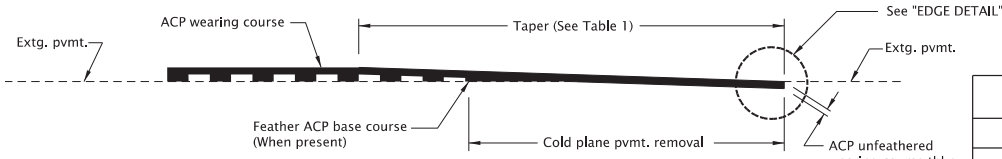

METHOD A *

* See project plans for method.

TABLE 1	
TAPER LENGTHS	
Posted Speed	Taper Length
< 45 mph	1" per 50'
≥ 45 mph	1" per 100'

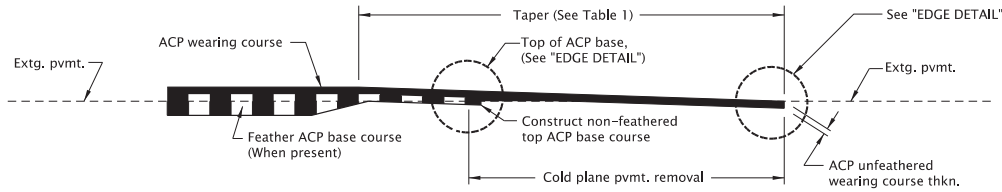

METHOD B *

**ACP PAVEMENT MATCH AT PROJECT ENDS
OR BRIDGE ENDS WHEN NOT OVERLAYING THE BRIDGE**

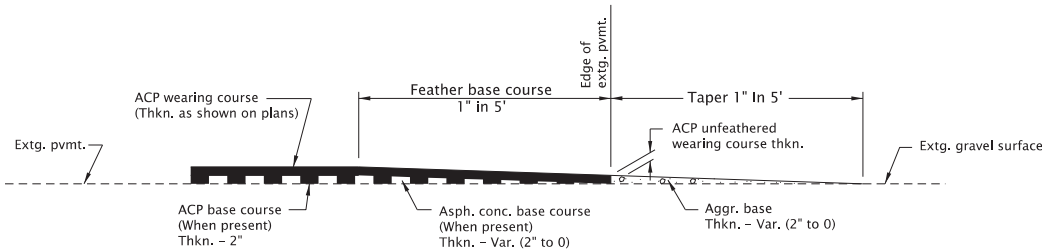
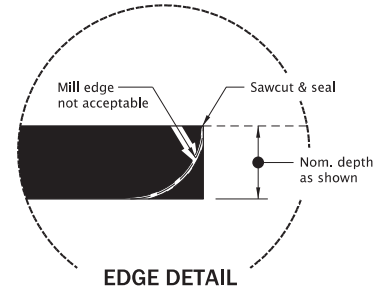

**METHOD OF FEATHERING ACP PAVEMENT
AT GRAVEL APPROACHES**

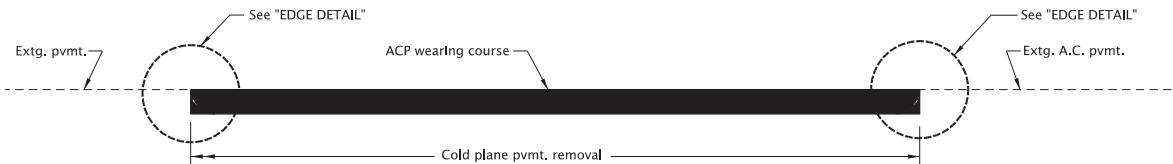

METHOD OF MATCHING EXTG. ACP INLAY SURFACING
(Inlay to extg. asphalt conc. pvmt.)

The selection and use of this Standard Drawing, while designed in accordance with generally accepted engineering principles and practices, is the sole responsibility of the user and should not be used without first consulting a Registered Professional Engineer.

All materials shall be in accordance with the current Oregon Standard Specifications.

OREGON STANDARD DRAWINGS
ASPHALT CONCRETE PAVEMENT (ACP) DETAILS

2021

DATE	REVISION	DESCRIPTION

CALC. BOOK NO. --- N/A --- SDR DATE: 25-JUL-2017 --- **RD610**

Effective Date: June 1, 2023 - November 30, 2023

TM500.dgn 07-01-2020

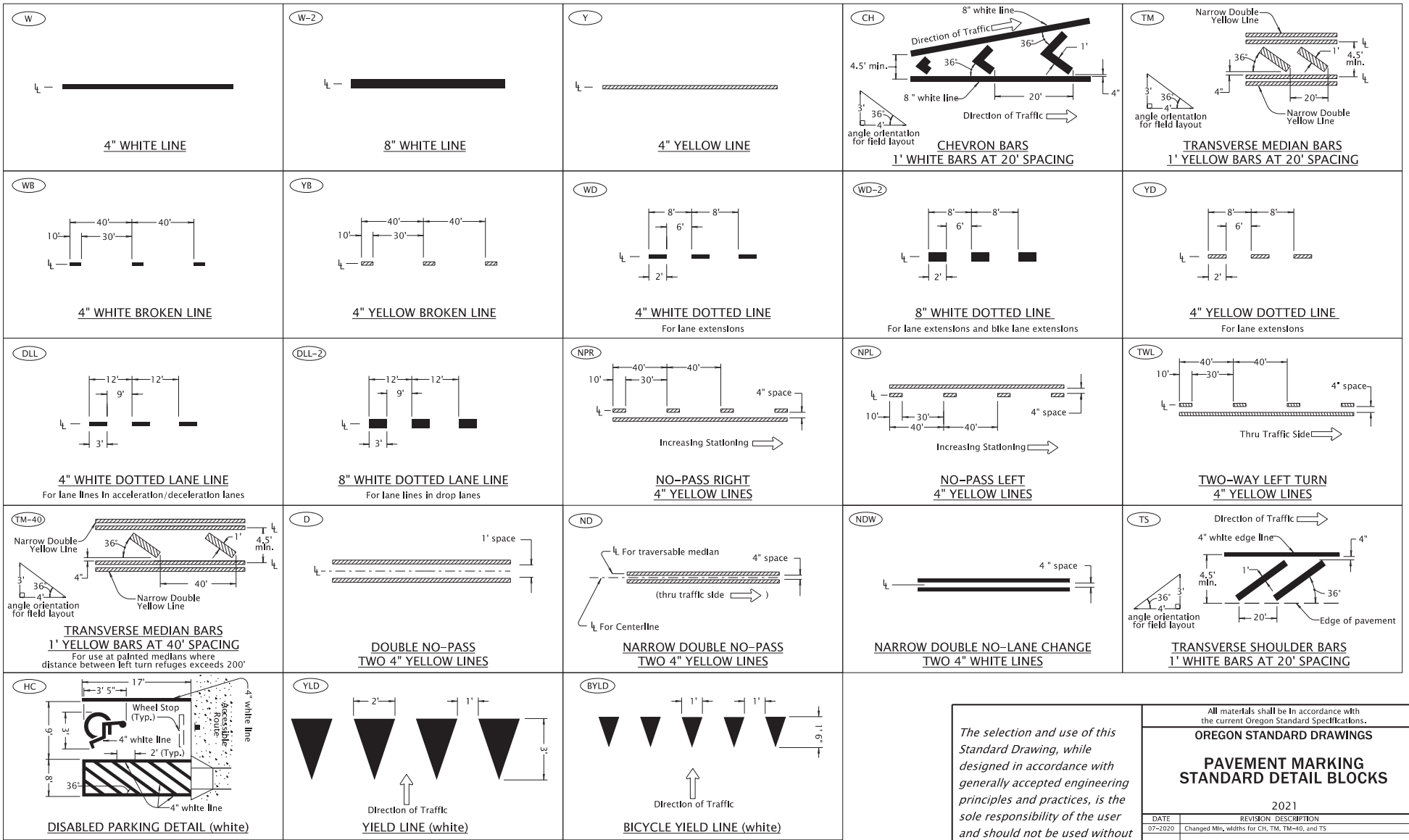

← Direction Of Traffic, Increasing Stationing Or Thru Traffic Side

⊥ — Lane line dimensions are shown on the striping plans

LEGEND

Effective Date: June 1, 2023 - November 30, 2023

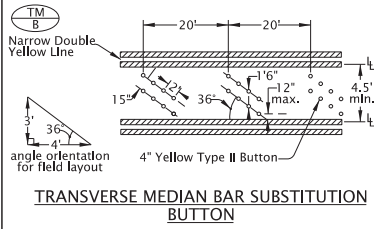

TRANSVERSE MEDIAN BAR SUBSTITUTION BUTTON

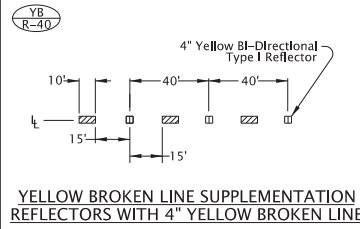

YELLOW BROKEN LINE SUPPLEMENTATION REFLECTORS WITH 4 INCH YELLOW BROKEN LINE

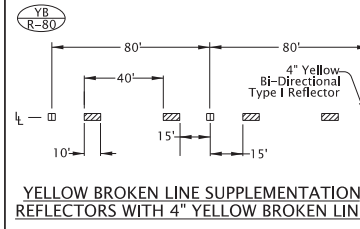

YELLOW BROKEN LINE SUPPLEMENTATION REFLECTORS WITH 4 INCH YELLOW BROKEN LINE

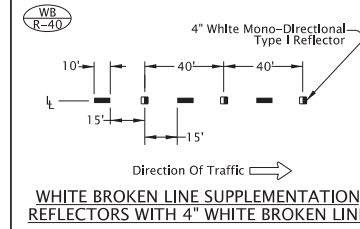

WHITE BROKEN LINE SUPPLEMENTATION REFLECTORS WITH 4 INCH WHITE BROKEN LINE

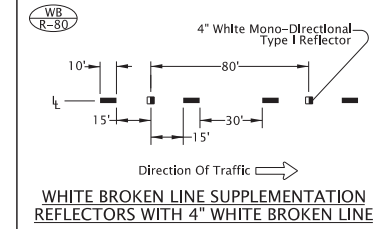

WHITE BROKEN LINE SUPPLEMENTATION REFLECTORS WITH 4 INCH WHITE BROKEN LINE

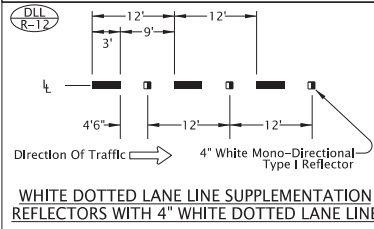

WHITE DOTTED LANE LINE SUPPLEMENTATION REFLECTORS WITH 4 INCH WHITE DOTTED LANE LINE

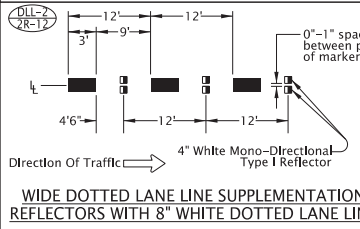

WIDE DOTTED LANE LINE SUPPLEMENTATION REFLECTORS WITH 8 INCH WHITE DOTTED LANE LINE

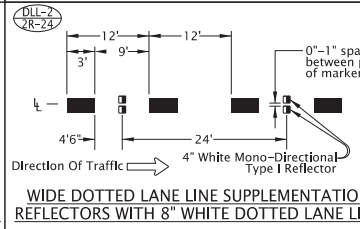

WIDE DOTTED LANE LINE SUPPLEMENTATION REFLECTORS WITH 8 INCH WHITE DOTTED LANE LINE

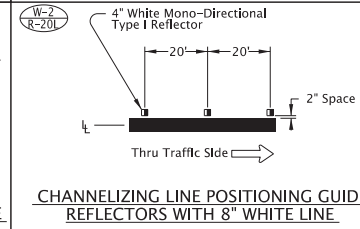

CHANNELIZING LINE POSITIONING GUIDE REFLECTORS WITH 8 INCH WHITE LINE

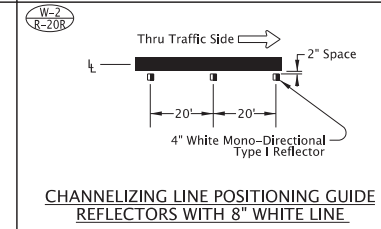

CHANNELIZING LINE POSITIONING GUIDE REFLECTORS WITH 8 INCH WHITE LINE

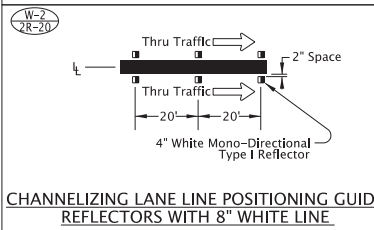

CHANNELIZING LANE LINE POSITIONING GUIDE REFLECTORS WITH 8 INCH WHITE LINE

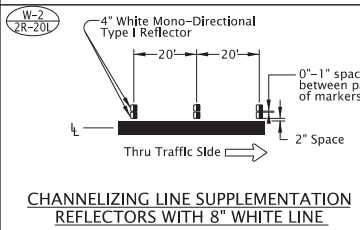

CHANNELIZING LINE SUPPLEMENTATION REFLECTORS WITH 8 INCH WHITE LINE

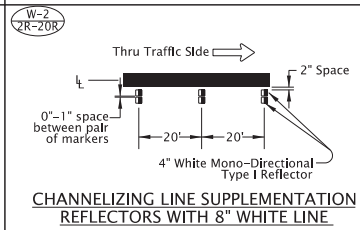

CHANNELIZING LINE SUPPLEMENTATION REFLECTORS WITH 8 INCH WHITE LINE

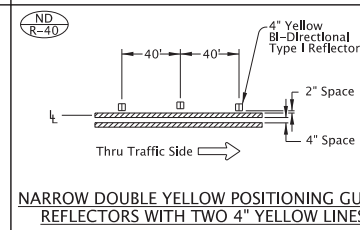

NARROW DOUBLE YELLOW POSITIONING GUIDE REFLECTORS WITH TWO 4 INCH YELLOW LINES

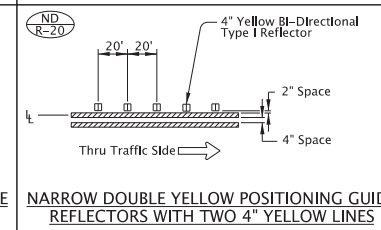

NARROW DOUBLE YELLOW POSITIONING GUIDE REFLECTORS WITH TWO 4 INCH YELLOW LINES

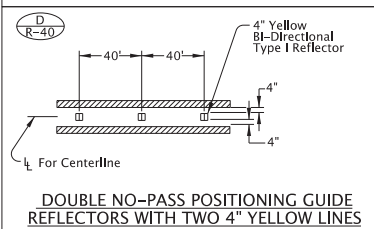

DOUBLE NO-PASS POSITIONING GUIDE REFLECTORS WITH TWO 4 INCH YELLOW LINES

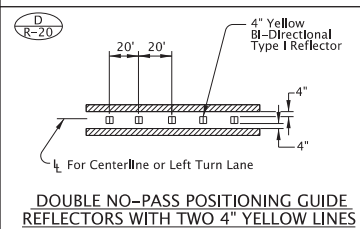

DOUBLE NO-PASS POSITIONING GUIDE REFLECTORS WITH TWO 4 INCH YELLOW LINES

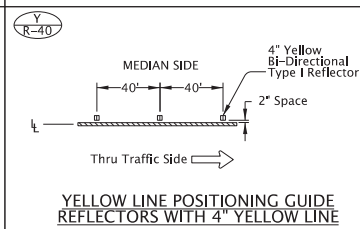

YELLOW LINE POSITIONING GUIDE REFLECTORS WITH 4 INCH YELLOW LINE

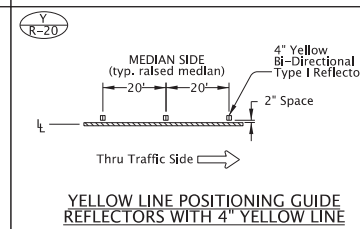

YELLOW LINE POSITIONING GUIDE REFLECTORS WITH 4 INCH YELLOW LINE

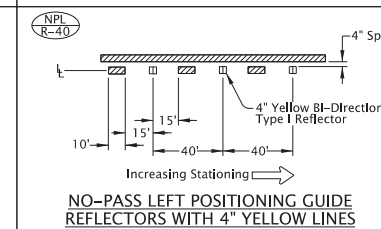

NO-PASS LEFT POSITIONING GUIDE REFLECTORS WITH 4 INCH YELLOW LINES

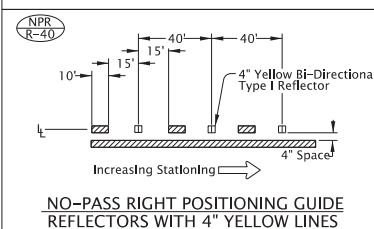

NO-PASS RIGHT POSITIONING GUIDE REFLECTORS WITH 4 INCH YELLOW LINES

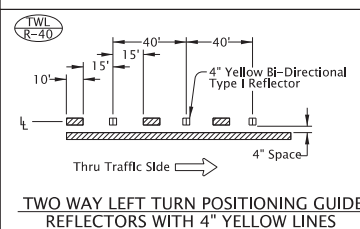





TWO WAY LEFT TURN POSITIONING GUIDE REFLECTORS WITH 4 INCH YELLOW LINES

General note:
1) Surface mount Raised Pavement Markers (RPMs) unless otherwise specified.

- LEGEND**
- ← Direction Of Travel, Increasing Stationing or Thru Traffic Side
 - Lane line dimensions are shown on the striping plans
 - Mono-directional crystal white marker reflects white to the left in this symbol
 - Bi-directional yellow marker reflects yellow both left and right in this symbol

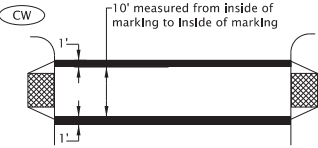
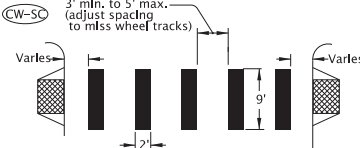
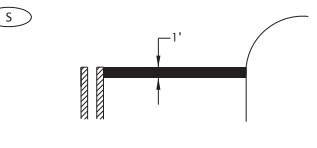
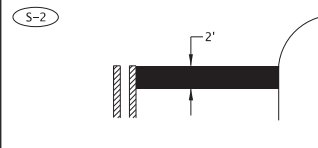
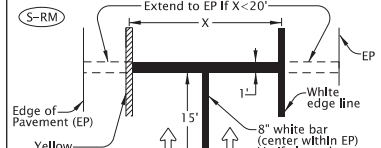
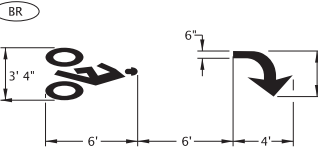
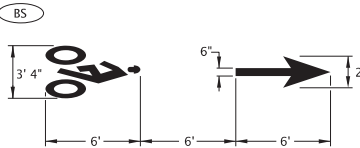
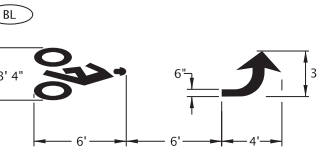
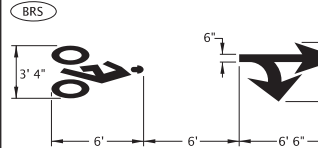
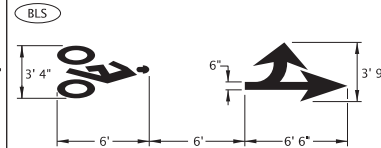
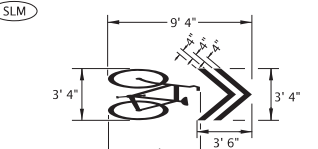
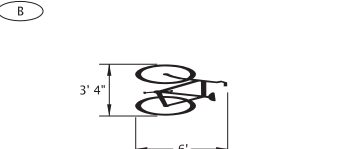
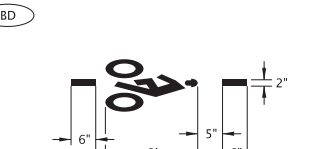
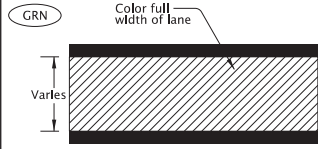
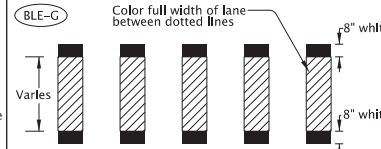
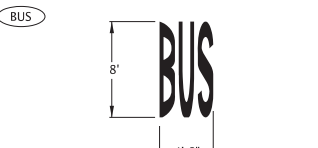
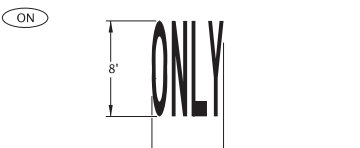
The selection and use of this Standard Drawing, while designed in accordance with generally accepted engineering principles and practices, is the sole responsibility of the user and should not be used without first consulting a Registered Professional Engineer.

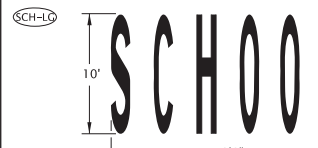
All materials shall be in accordance with the current Oregon Standard Specifications.	
OREGON STANDARD DRAWINGS	
PAVEMENT MARKING STANDARD DETAIL BLOCKS	
2021	
DATE	REVISION DESCRIPTION
07-2020	Changed mls, width of TM/ B from 6" to 4.5"
01-2022	Removed "LANE" from W-2/R-20R title
CALC. BOOK NO.	SDR DATE
N/A	01-03-2022
TM502	

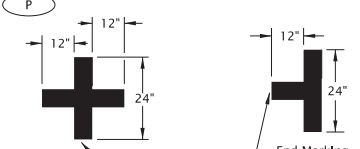
 <p>CW</p> <p>STANDARD CROSSWALK TWO 1' WHITE BARS</p> <p>Install per Standard Drawing TM530</p>	 <p>CW-SC</p> <p>STAGGERED CONTINENTAL CROSSWALK 2' WHITE BARS</p> <p>Install per Standard Drawing TM530</p>	 <p>S</p> <p>STOP BAR 1' WHITE BAR</p> <p>Install per Standard Drawing TM530</p>	 <p>S-2</p> <p>STOP BAR - LARGE 2' WHITE BAR</p> <p>Install per Standard Drawing TM530</p>	 <p>S-RM</p> <p>RAMP METER STOP BAR 1' & 8" WHITE BARS</p> <p>For multi-lane ramp meter applications</p>
 <p>BR</p> <p>BIKE RIGHT TURN STENCIL (white)</p> <p>Center marking within lane width For proportion details, see current version of Standard Highway Signs</p>	 <p>BS</p> <p>BIKE LANE STANDARD STENCIL (white)</p> <p>Center marking within lane width For proportion details, see current version of Standard Highway Signs</p>	 <p>BL</p> <p>BIKE LEFT TURN STENCIL (white)</p> <p>Center marking within lane width For proportion details, see current version of Standard Highway Signs</p>	 <p>BRS</p> <p>BIKE RIGHT TURN STRAIGHT STENCIL (white)</p> <p>Center marking within lane width For proportion details, see current version of Standard Highway Signs</p>	 <p>BLS</p> <p>BIKE LEFT TURN STRAIGHT STENCIL (white)</p> <p>Center marking within lane width For proportion details, see current version of Standard Highway Signs</p>
 <p>SLM</p> <p>SHARED LANE MARKING (white)</p> <p>Center marking within lane width or as shown For proportion details, see current version of Standard Highway Signs</p>	 <p>B</p> <p>BIKE STENCIL (white)</p> <p>Used for Intersection Bicycle Box applications Place marking within bicycle box, centered with motor vehicle lane width</p>	 <p>BD</p> <p>BICYCLE DETECTOR MARKING (white)</p> <p>Place Bicycle Detector Pavement Marking in optimum location where bicycle acuates the traffic signal</p>	 <p>GRN</p> <p>GREEN SUPPLEMENTAL BICYCLE LANE SOLID LINE (green)</p>	 <p>BLE-G</p> <p>GREEN SUPPLEMENTAL BICYCLE LANE DOTTED LINE EXTENSION (green)</p>
 <p>BUS</p> <p>BUS (white)</p> <p>Center marking within lane width For letter proportion details, see current version of Standard Highway Signs</p>	 <p>ON</p> <p>ONLY (white)</p> <p>Center marking within lane width For letter proportion details, see current version of Standard Highway Signs</p>	 <p>SCHOOL</p> <p>SCHOOL (white)</p> <p>Center marking within lane width For letter proportion details, see current version of Standard Highway Signs</p>	 <p>SCHOOL</p> <p>SCHOOL - LARGE (white)</p> <p>Center marking within width of two lanes For letter proportion details, see current version of Standard Highway Signs</p>	 <p>CROSSING</p> <p>CROSSING - LARGE (white)</p> <p>Center marking within width of two lanes For letter proportion details, see current version of Standard Highway Signs</p>
 <p>X-ING</p> <p>X-ING (white)</p> <p>Center marking within lane width For letter proportion details, see current version of Standard Highway Signs</p>	 <p>P</p> <p>ON-STREET PARKING DETAIL (white)</p>	<div style="border: 1px solid black; padding: 5px;"> <p>General Note:</p> <p>1. Arrow, letter, and bike symbol dimensions nominal.</p> </div>		

LEGEND
← Direction of Travel

The selection and use of this Standard Drawing, while designed in accordance with generally accepted engineering principles and practices, is the sole responsibility of the user and should not be used without first consulting a Registered Professional Engineer.

All materials shall be in accordance with the current Oregon Standard Specifications.	
OREGON STANDARD DRAWINGS	
PAVEMENT MARKING	
STANDARD DETAIL BLOCKS	
2021	
DATE	REVISION DESCRIPTION
07-2022	Added note for measurement of Standard Crosswalk
CALC. BOOK NO.	SDR DATE
N/A	07-08-2022
TM503	

TM560.dgn 07-01-2020

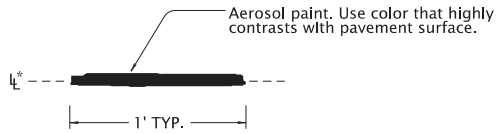

CONTROL POINT

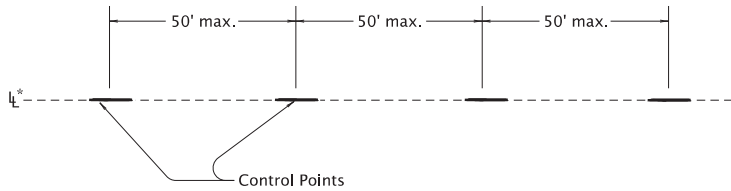

CONTROL POINT LAYOUT - TANGENT SECTIONS

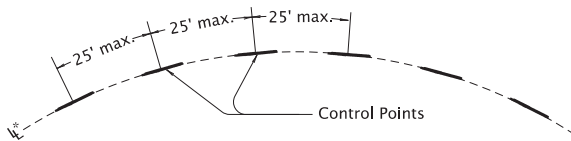

CONTROL POINT LAYOUT - CURVE SECTIONS

General note:

1.) Use control points to make continuous narrow guideline as specified.

* Control points are placed along the lane line for all longitudinal lines except the following:



For center lines only

A control point layout 4" offset from the lane line is required for a ND line when used as a center line.

LEGEND

\perp — Lane line dimensions are shown on the striping plans.

To be accompanied by Standard Dwg. Nos. TM500 thru TM504

The selection and use of this Standard Drawing, while designed in accordance with generally accepted engineering principles and practices, is the sole responsibility of the user and should not be used without first consulting a Registered Professional Engineer.

All materials shall be in accordance with the current Oregon Standard Specifications.	
OREGON STANDARD DRAWINGS	
ALIGNMENT LAYOUT: GENERAL	
2021	
DATE	REVISION DESCRIPTION
07-2020	Extended accompanied by drawings to include TM504
CALC. BOOK NO. --- N/A ---	SDR DATE 07-01-2020
TM560	

Effective Date: June 1, 2023 - November 30, 2023

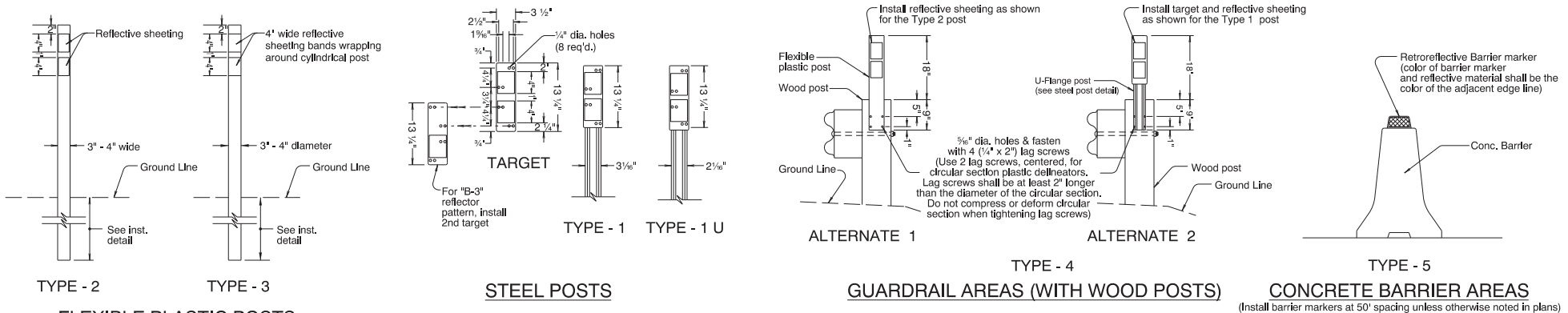

STEEL POSTS

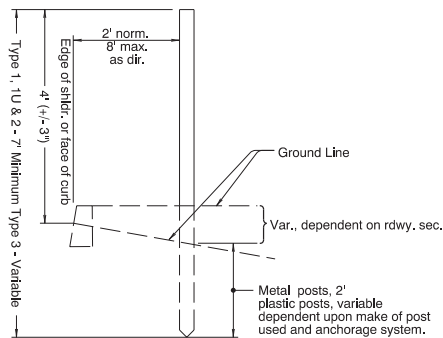

INSTALLATION DETAIL

GUARDRAIL AREAS (WITH WOOD POSTS)

NOTES:
POST: Galv. steel, nominal weight Type 1, 2 lb/ft, Type 1 U, 1, 12 lb/ft.
 See Standard Drawing TM571 for steel post dimensions and details.
TARGET: Aluminum sheet, nominal thickness .050". Fasten to post with 5/16" dia. aluminum blind rivets and washers.
 For "B-3" reflector pattern, top target shall overlap bottom target.
REFLECTORS: 3' x 4" reflective sheeting unless otherwise shown. (3 1/2" x 4" reflective sheeting is an acceptable alternate unless otherwise shown.)
 Acrylic prismatic reflectors acceptable on Type 1, 1 U, 2 and 4 posts and Type 5 barrier mounts.
 Place required number in sequence from top of target.

- GENERAL NOTES:**
- Spacing shall be measured along the shoulder.
 - On roads with less than 500 vehicle ADT, delineators are not to be used except where situations such as sharp horizontal curves, etc. exist.
 - To clear driveways, crossroads etc., or for required adjustments at ramps and at intersections, either:
 (a) vary placement of that post up to 25% of spacing shown, or;
 (b) eliminate said post if limit of variation must be exceeded.
 - Judgement should be exercised in the installation of delineators in cut section, particularly on roads constructed to older standards where ditches are narrow and where delineators tend to hamper maintenance operations.
 - On horizontal curves place delineators nearly opposite each other.
 - At guard rail locations the delineators are to be installed behind the rail and shall be located adjacent to guard rail posts as shown for Type 4 Delineators.
 - Install all delineators with reflectors facing adjacent oncoming traffic.
 - Offset delineators an additional 4' in areas of heavy snow removal operations.
 - Backside Delineators may be used in frequently snow plowed areas where use of snow poles is not justified. When Backside Delineators are specified, substitute "W-1" and "W-2" with "W-1B" and "W-2B" respectively, on Type 1 steel posts. Do not install Backside Delineators on one-way sections of roadway, freeways and ramps, or on radius sections.
 - Refer to TM 222 for bracket assembly details for Backside Reflector Pattern.

REFLECTOR PATTERN TABLE					
	Color Type	Color Of Reflector And Target Or Post	Number Of Reflectors	Color Of Reflector And Target Or Post On Backside	Number Of Reflectors On Backside
Standard Pattern	"W-1"	White	1	Not Applicable	Not Applicable
	"W-2"	White	2		
	"Y-1"	Yellow	1		
	"Y-2"	Yellow	2		
	"B-1"	Blue	1		
	"B-2"	Blue	2		
	"B-3"	Blue	3		
Backside Pattern	"W-1B"	White	1	White	2
	"W-2B"	White	2	White	2

TANGENT ▲ MAX. SPACING EACH SIDE OF ROADWAY IN FEET	HORIZONTAL CURVES ▲ MAX. SPACING EACH SIDE OF ROADWAY IN FEET				
	DEGREE OF CURVE	ON CURVE	IN ADVANCE OF & BEYOND CURVE		
			FIRST SPACE	SECOND SPACE	THIRD SPACE
400	Lower Than 1	300	300	300	300
	1	230	300	300	300
	2	160	300	300	300
	3	130	260	300	300
	4	110	220	300	300
	5	100	200	300	300
	6	90	180	270	300
	7 - 8	80	160	240	300
	9 - 11	70	140	210	300
	12 - 16	60	120	180	300
	17 - 22	50	100	150	300
	23 - 34	40	80	120	240
	35 - 53	30	60	90	180
	54 & Higher	20	40	60	120

(Min. spacing 20 feet)
 (▲ Install "W-1" reflective pattern unless otherwise noted. See Standard Drawings TM575 thru TM577 for spacing, layout, and reflective pattern of delineators at interchange ramps, channelized intersections, lane reductions, emergency escape ramps and freeway crossovers.)

DELINEATOR SPACING TABLE FOR TYPES 1, 1U, 2, and 4

To be accompanied by Drg. No. TM571, TM575, TM576, and/or TM577 as specified.

The selection and use of this Standard Drawing, while designed in accordance with generally accepted engineering principles and practices, is the sole responsibility of the user and should not be used without first consulting a Registered Professional Engineer.

All materials shall be in accordance with the current Oregon Standard Specifications.	
OREGON STANDARD DRAWINGS	
TRAFFIC DELINEATORS	
2021	
DATE	REVISION DESCRIPTION
CALC. BOOK NO. --- N/A ---	SDR DATE: 06-JAN-2012 -- TM570

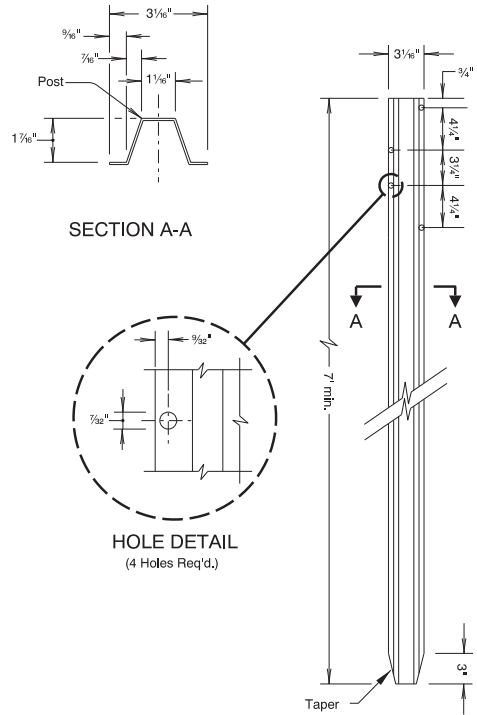

Notes:
1. Galv. steel, nominal weight 2 lb. per ft.

TYPE - 1 STEEL POST DIMENSIONS

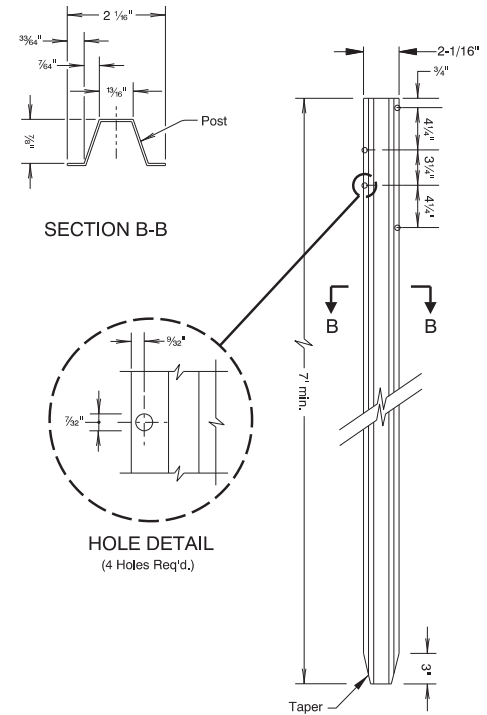

Notes:
1. Galv. steel, nominal weight 1.12 lb. per ft.

TYPE - 1 U STEEL POST DIMENSIONS

To be accompanied by Drg. No. TM570

The selection and use of this Standard Drawing, while designed in accordance with generally accepted engineering principles and practices, is the sole responsibility of the user and should not be used without first consulting a Registered Professional Engineer.

All materials shall be in accordance with the current Oregon Standard Specifications.

OREGON STANDARD DRAWINGS

TRAFFIC DELINEATORS

STEEL POST DETAILS

2021

DATE	REVISION	DESCRIPTION

CALC. BOOK NO. --- N/A ---	SDR DATE: 10-DEC-2009	TM571
----------------------------	-----------------------	--------------

TM821.dgn 01-JUL-2020

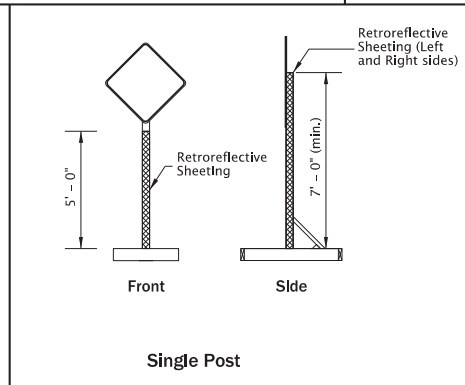
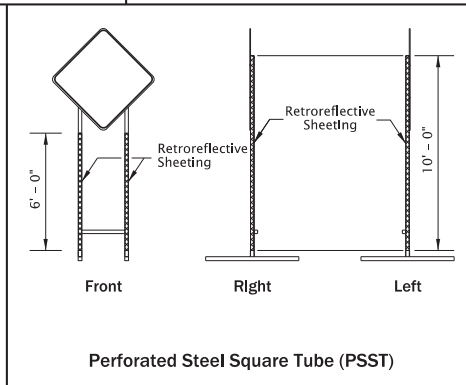
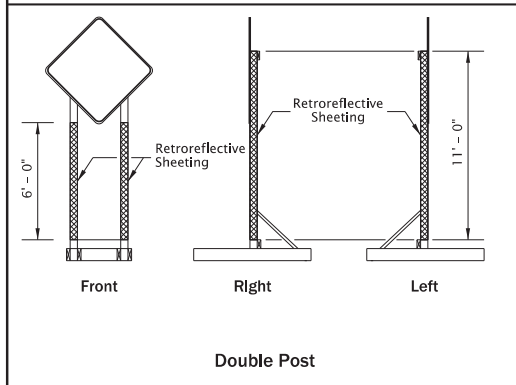
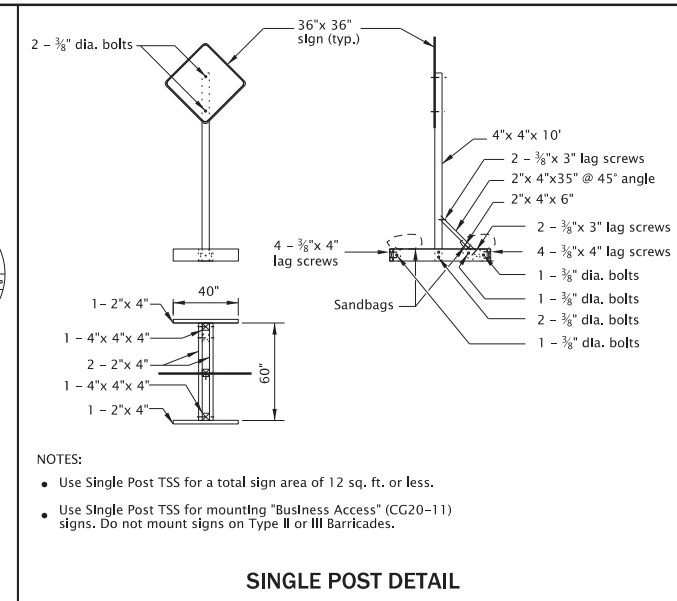
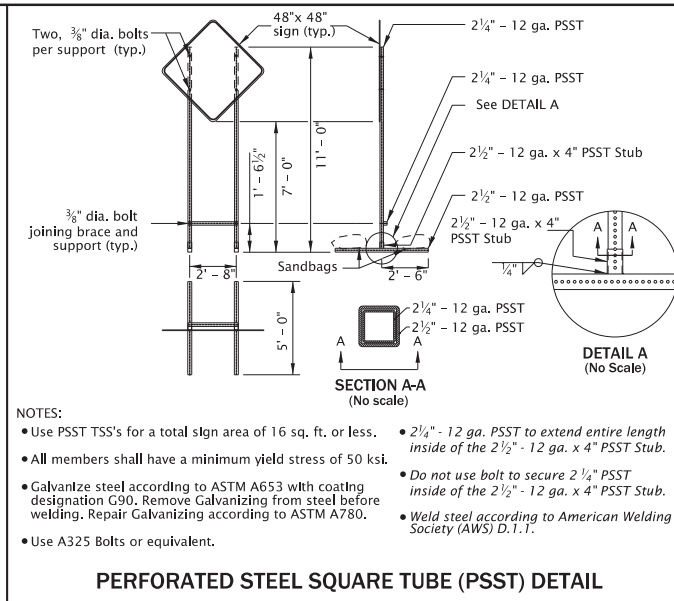
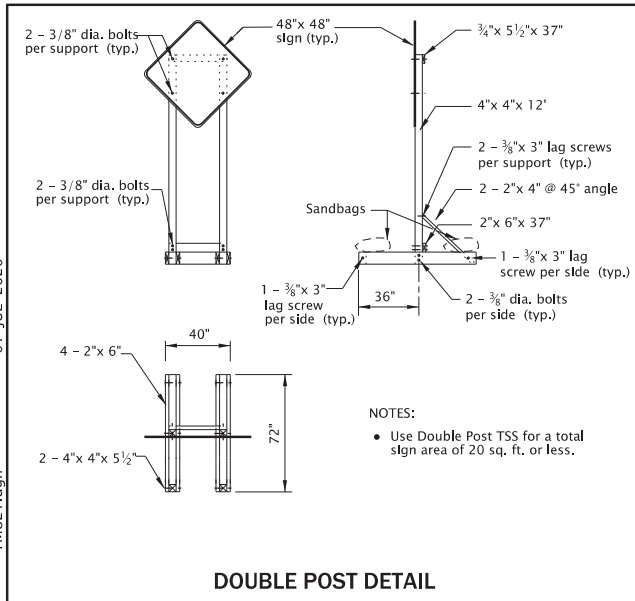

TEMPORARY SIGN SUPPORT GENERAL NOTES:

- Do not tip over TSS at any time.
- Do not locate TSS's in locations that block pedestrian or bicycle traffic.
- For wooden TSS's, use either Douglas Fir or Hem Fir, which is surfaced four sides (S4S) and free of heart center (FOHC).
- See "Temporary Sign Placement" detail on TM822 for sign installation heights.
- Do not place or stack ballast more than 24" above the ground.
- When sign is inconsistent with current work zone conditions, cover sign; or turn sign 90 degrees away from approaching traffic. Remove TSS from roadway when signing is not needed for more than 3 days.
- Place a minimum of 50 lbs of sandbags on each of the four TSS supports legs. (25 lb. max per bag) (min. 100 lbs per side of each TSS).
- See Dwg. No. TM204 for flag board mounting detail.

NOTES:

- Apply fluorescent orange, ANSI Type VIII or IX retroreflective sheeting to TSS posts, as shown, for all temporary signs, except "STOP" and "DO NOT ENTER". For "STOP" and "DO NOT ENTER" signs, used red ANSI Type III or IV retroreflective sheeting on the TSS posts.
- Apply sign post retroreflectivity to each TSS post facing front; and to the left and right sides of the TSS, as shown. Use 3" wide sheeting for wood post TSS's. Use 2" wide sheeting for PSST TSS's.
- Sheeting may be applied directly to post material; or applied to a rigid, lightweight substrate, then securely attached to the posts.

SIGN POST REFLECTIVE SHEETING PLACEMENT

NOTES:

- Use PSST TSS's for a total sign area of 16 sq. ft. or less.
- All members shall have a minimum yield stress of 50 ksi.
- Galvanize steel according to ASTM A653 with coating designation G90. Remove Galvanizing from steel before welding. Repair Galvanizing according to ASTM A780.
- Use A325 Bolts or equivalent.
- 2 1/4" - 12 ga. PSST to extend entire length inside of the 2 1/2" - 12 ga. x 4" PSST Stub.
- Do not use bolt to secure 2 1/2" PSST inside of the 2 1/2" - 12 ga. x 4" PSST Stub.
- Weld steel according to American Welding Society (AWS) D.1.1.

The selection and use of this Standard Drawing, while designed in accordance with generally accepted engineering principles and practices, is the sole responsibility of the user and should not be used without first consulting a Registered Professional Engineer.

All materials shall be in accordance with the current Oregon Standard Specifications.

OREGON STANDARD DRAWINGS

TEMPORARY SIGN SUPPORTS

2021

DATE	REVISION	DESCRIPTION

CALC. BOOK NO. --- N/A --- SDR DATE: 01-JUL-2020 --- **TM821**

Effective Date: June 1, 2023 - November 30, 2023

NOTES:

- Do not block bicycle lanes, sidewalks, or TPAs with sign supports. Maintain minimum widths for these facilities according to TCP Design Manual, MUTCD, ADA, or as directed.
- To be accompanied by Dwg. Nos. TM670, TM671, TM687, TM688 & TM689.

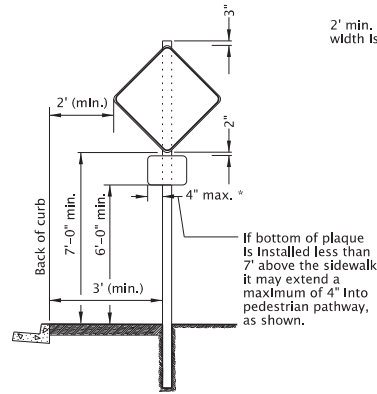

Urban Areas With Curb/Sidewalk

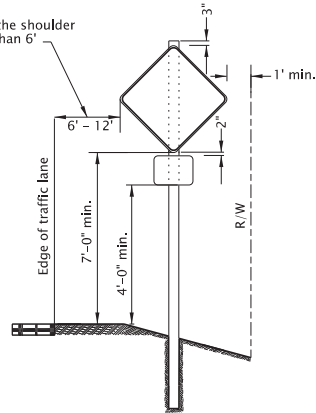

Rural Areas

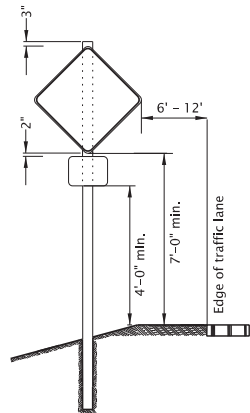

Divided Highway/Freeway Medians
No Curb/Sidewalk

Where temporary signs are located adjacent to or intrude into a paved shoulder or other surface used by bicycle traffic, install secondary sign (plaque) so bottom of sign is a minimum of 7'-0" above pavement surface, as shown.

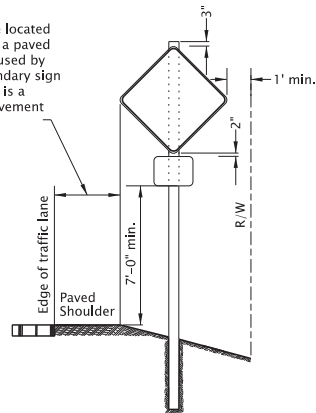

Rural or Urban Areas - Curb or No Curb
Bicycles On Shoulder

TEMPORARY SIGN PLACEMENT

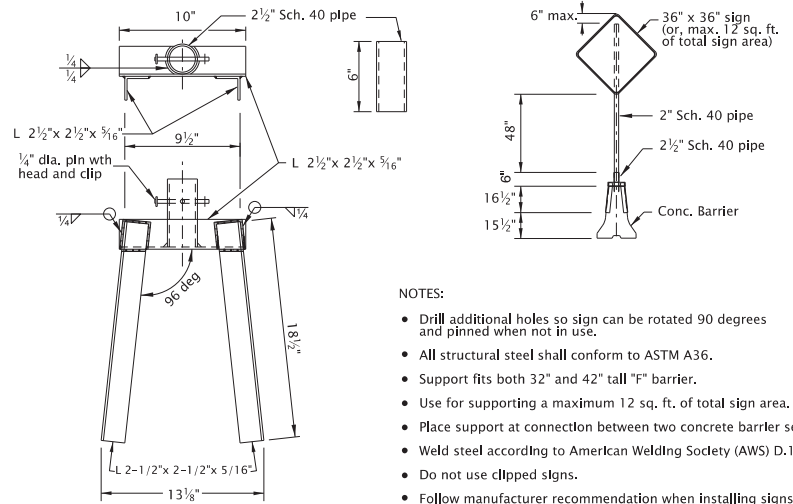

NOTES:

- Drill additional holes so sign can be rotated 90 degrees and pinned when not in use.
- All structural steel shall conform to ASTM A36.
- Support fits both 32" and 42" tall "F" barrier.
- Use for supporting a maximum 12 sq. ft. of total sign area.
- Place support at connection between two concrete barrier sections.
- Weld steel according to American Welding Society (AWS) D.1.1.
- Do not use clipped signs.
- Follow manufacturer recommendation when installing signs on barrier other than concrete.

CONCRETE BARRIER SIGN SUPPORT

The selection and use of this Standard Drawing, while designed in accordance with generally accepted engineering principles and practices, is the sole responsibility of the user and should not be used without first consulting a Registered Professional Engineer.

All materials shall be in accordance with the current Oregon Standard Specifications.

OREGON STANDARD DRAWINGS

TEMPORARY SIGN SUPPORTS

2021

DATE	REVISION	DESCRIPTION

CALC. BOOK NO. - - - - -	N/A	SDR DATE - 01-JUL-2020	TM822
--------------------------	-----	------------------------	-------

01-JUL-2022

TM850.dgn

- NOTE:
- Continue "LOOSE GRAVEL" (CW8-7a) and "DO NOT PASS" (R4-1) signing throughout the area at spacing shown.
 - Use advisory speed "XX", 15 mph less than the pre-construction posted speed, or as directed. "XX MPH" placard shall not exceed a posted speed of 35 mph.

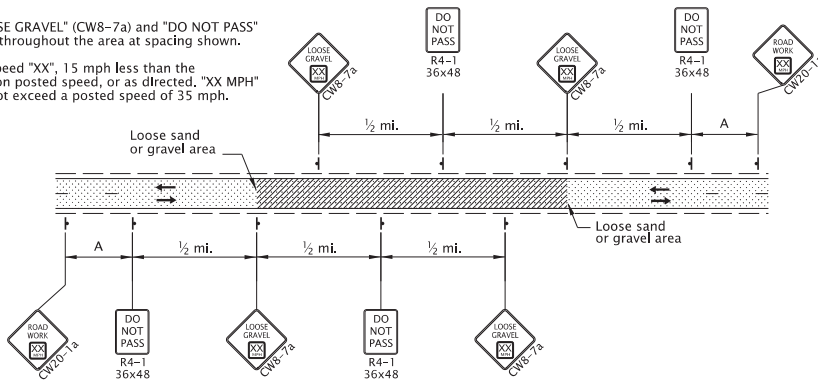

2-Lane, 2-Way Roadway
LOOSE GRAVEL IN ROADWAY SIGNING

- NOTE:
- Continue "ABRUPT EDGE" (CW21-(7,9)) and "DO NOT PASS" (R4-1) signing throughout the area at spacing shown.

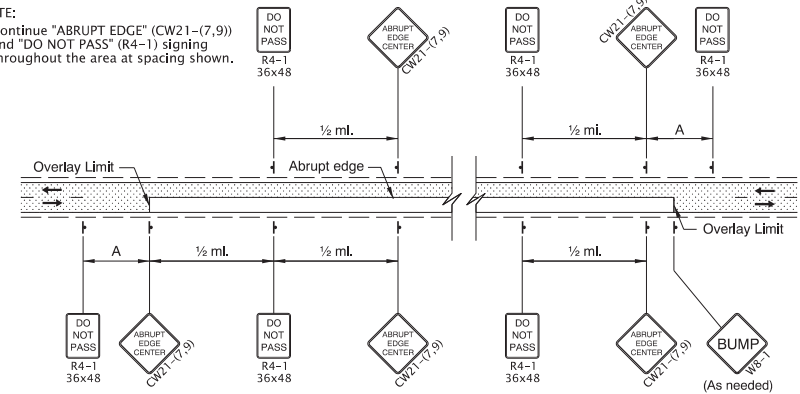

2-Lane, 2-Way Roadway
OVERLAY AREA SIGNING

- NOTES:
- Place Advance Flagger and additional signing when traffic queues extend beyond initial warning signing OR when sight distance is restricted.
 - Relocate initial "ROAD WORK AHEAD" (W20-1) sign in advance of additional "BE PREPARED TO STOP" (W3-4) and Flagger Ahead (CW23-2) signs, as shown.

- Place additional Tubular Markers for Flagger and Advance Flagger Stations according to FLAGGER STATION DELINEATION detail.

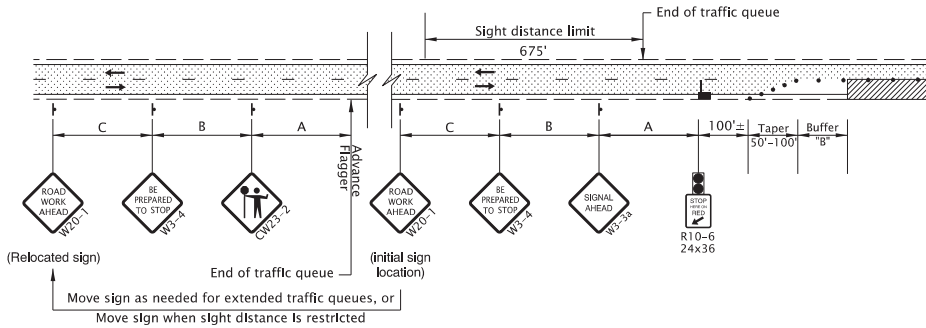

ADVANCE FLAGGER FOR EXTENDED TRAFFIC QUEUES

NOTE:

- When using pilot cars with flaggers to control traffic during paving operations, the Tubular Marker spacing along centerline may be increased to 200' within the Activity Area, as shown or as directed.
- Include "WAIT FOR FLAGGER" (CR4-23) signs mounted on Type II Barricade located approx. 50' before each Flagger.
- Coordinate and control pedestrians movements through the TPAR using Flaggers, other TCM, or as directed. When the existing shoulder is greater than or equal to 4' wide, provide a minimum of 4' of width for the TPAR.

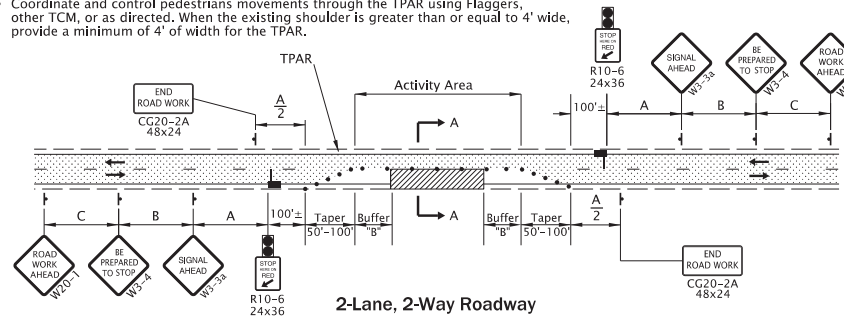
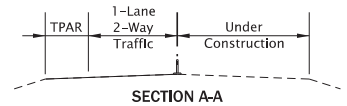

2-Lane, 2-Way Roadway
ONE LANE CLOSURE

GENERAL NOTES FOR ALL DETAILS:

- The "SIGNAL AHEAD" (W3-3a) sign may be substituted with the Signal Ahead (W3-3) symbol sign.
- Cover existing passing zone signing, as directed.
- Install temporary striping as required.
- To determine Taper Length ("L") and Buffer Length ("B"), use the "MINIMUM LENGTHS TABLE" shown on Dwg. No. TM800.
- To determine sign spacing A, B, and C, use "TRAFFIC CONTROL DEVICES (TCD) SPACING TABLE" on Dwg. No. TM800.
- Install a "BICYCLES ON ROADWAY" (CW11-1) sign in advance of the closure when a bike lane is closed, or when the shoulder is closed and bikes are expected.
- At night, flagger stations shall be illuminated according to the FLAGGER STATION LIGHTING DELINEATION detail on Dwg. No. TM800.

- To be accompanied by Dwg. Nos. TM820, TM821 & TM854.
- Automated Flagging Assistance Device (AFAD)
- 28" Tubular Markers on 20' max. spacing for flagger tapers and stations
- 28" Tubular Markers See TCD Spacing Table on TM800 for max. spacing.

- UNDER TRAFFIC
- UNDER CONSTRUCTION
- CONSTRUCTION UNDER TRAFFIC

NOTE:

- Use a minimum of 3 tubular markers in shoulder taper on 10' spacing for flagger station delineation.

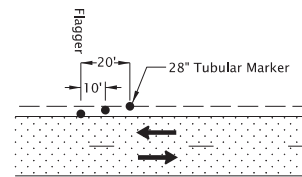

FLAGGER STATION DELINEATION

The selection and use of this Standard Drawing, while designed in accordance with generally accepted engineering principles and practices, is the sole responsibility of the user and should not be used without first consulting a Registered Professional Engineer.

All materials shall be in accordance with the current Oregon Standard Specifications.

OREGON STANDARD DRAWINGS

2-LANE, 2-WAY ROADWAYS

2021

DATE	REVISION	DESCRIPTION
01-2022	Added AFADs to drawing.	

CALC. BOOK NO. N/A SDR DATE 01-JUL-2022 TM850

Effective Date: June 1, 2023 - November 30, 2023

13-JAN-2023
TM855.dgn

NOTES:

- Place Advance Flagger and additional signing when traffic queues extend beyond initial warning signing OR when sight distance is restricted.
- Place additional Tubular Markers for Flagger and Advance Flagger Stations according to FLAGGER STATION DELINEATION detail.
- Relocate initial "ROAD WORK AHEAD" (W20-1) sign in advance of additional "BE PREPARED TO STOP" (W3-4) and Flagger Ahead (CW23-2) signs, as shown.

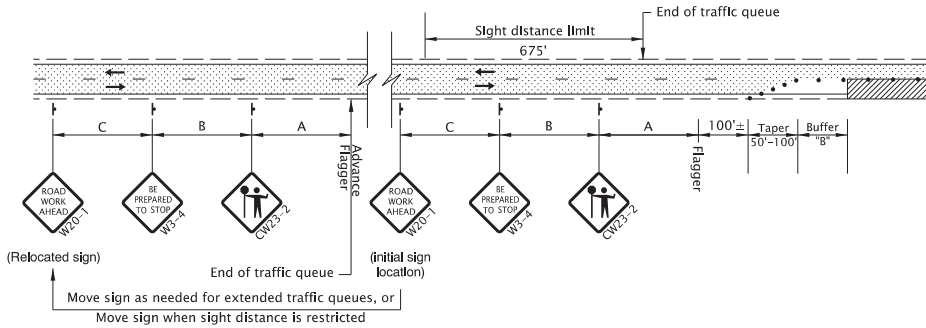

ADVANCE FLAGGER FOR EXTENDED TRAFFIC QUEUES

NOTE:

- When using pilot cars with flaggers to control traffic during paving operations, the Tubular Marker spacing along centerline may be increased to 200' within the Activity Area, as shown or as directed.
- Include "WAIT FOR FLAGGER" (CR4-23) signs mounted on Type II Barricade located approx. 50' before each Flagger.
- Coordinate and control pedestrians movements through the TPAR using Flaggers, other TCM, or as directed. When the existing shoulder is greater than or equal to 4' wide, provide a minimum of 4' of width for the TPAR.

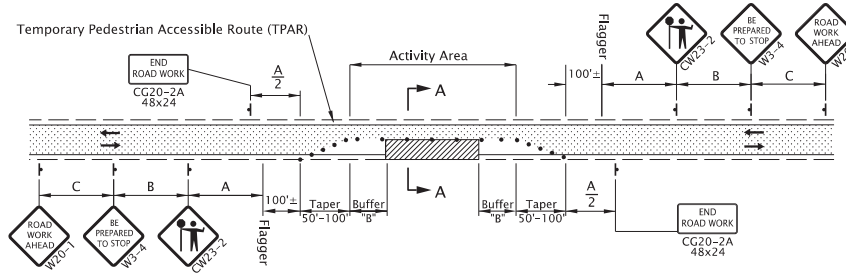
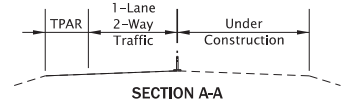

2-Lane, 2-Way Roadway ONE LANE CLOSURE

GENERAL NOTES FOR ALL DETAILS:

- This drawing is only intended to be used where an Automated Flagger Assistance Device (AFAD) cannot be utilized.
- The "FLAGGER" (CW23-2) symbol sign shall be used only in conjunction with the "BE PREPARED TO STOP" (W3-4) sign.
- Cover existing passing zone signing, as directed.
- Install temporary striping as required.
- To determine Taper Length ("L") and Buffer Length ("B"), use the "MINIMUM LENGTHS TABLE" shown on Dwg. No. TM800.
- To determine sign spacing A, B, and C, use "TRAFFIC CONTROL DEVICES (TCD) SPACING TABLE" on Dwg. No. TM800.
- Install a "BICYCLES ON ROADWAY" (CW11-1) sign in advance of the closure when a bike lane is closed, or when the shoulder is closed and bikes are expected.
- At night, flagger stations shall be illuminated according to the FLAGGER STATION LIGHTING DELINEATION detail on Dwg No. TM800.
- To be accompanied by Dwg. Nos. TM820 & TM821.

- 28" Tubular Markers on 10' max. spacing around intersection radii.
- 28" Tubular Markers on 20' max. spacing for flagger tapers and stations
- • • 28" Tubular Markers See TCD Spacing Table on TM800 for max. spacing.

UNDER TRAFFIC
 UNDER CONSTRUCTION

NOTE:

- Additional Traffic Control Measures (TCM) may be required for all legs of the intersection

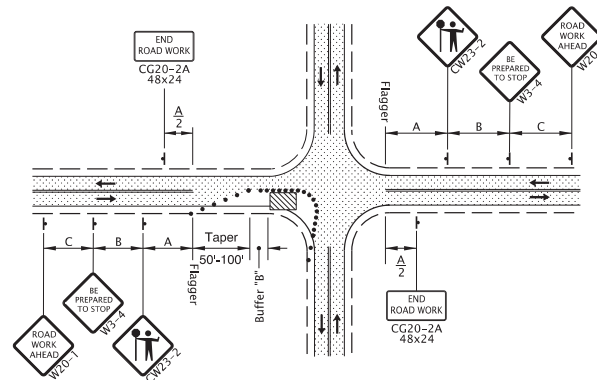

2-Lane, 2-Way Roadway ONE LANE CLOSURE, INTERSECTION

NOTE:

- Use a minimum of 3 tubular markers in shoulder taper on 10' spacing for flagger station delineation.

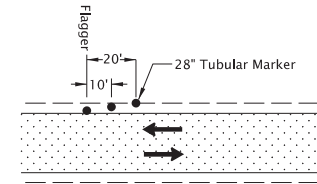

FLAGGER STATION DELINEATION

The selection and use of this Standard Drawing, while designed in accordance with generally accepted engineering principles and practices, is the sole responsibility of the user and should not be used without first consulting a Registered Professional Engineer.

All materials shall be in accordance with the current Oregon Standard Specifications.

OREGON STANDARD DRAWINGS

2-LANE, 2-WAY ROADWAYS

2021

DATE	REVISION	DESCRIPTION

CALC. BOOK NO. --- N/A --- SDR DATE: 13-JAN-2023 --- **TM855**

Effective Date: June 1, 2023 - November 30, 2023