

DESCHUTES MARKET RD / HAMEHOOK RD

C.O.I.D. CANAL CROSSING IMPROVEMENTS

DESCHUTES COUNTY, OREGON

OCTOBER, 2022

GENERAL NOTES

- ALL WORK SHOWN ON THESE PLANS TO BE PERFORMED UNDER CONTRACT SHALL BE CONSTRUCTED IN ACCORDANCE WITH THE CONTRACT SPECIAL PROVISIONS AND THE OREGON STATE "OREGON STANDARD SPECIFICATIONS FOR CONSTRUCTION," REVISED 2021.
- THE LOCATION AND DESCRIPTIONS OF EXISTING UTILITIES SHOWN ARE COMPILED FROM AVAILABLE RECORDS AND/OR FIELD SURVEYS. THE COUNTY AND UTILITY COMPANIES DO NOT GUARANTEE THE ACCURACY NOR THE COMPLETENESS OF SUCH RECORDS. LOCATIONS SHOWN ARE APPROXIMATE AND TO BE VERIFIED BY THE CONTRACTOR PRIOR TO CONSTRUCTION. ADDITIONAL UNDERGROUND UTILITIES MAY EXIST WHICH ARE NOT SHOWN HEREIN.
- ATTENTION: OREGON LAW REQUIRES YOU TO FOLLOW RULES ADOPTED BY THE OREGON UTILITY NOTIFICATION CENTER. THOSE RULES ARE SET FORTH IN OAR 952-001-0010 THROUGH 952-001-0090. YOU MAY OBTAIN COPIES OF THE RULES BY CALLING THE CENTER. (NOTE: THE ADMINISTRATIVE TELEPHONE NUMBER FOR THE OREGON UTILITY NOTIFICATION CENTER IS (503) 232-1987).
- PROVISIONS SHALL BE MADE BY THE CONTRACTOR TO KEEP ALL EXISTING UTILITIES IN SERVICE AND PROTECT THEM DURING CONSTRUCTION BY ANY MEANS NECESSARY.
- UTILITIES, OR INTERFERING PORTIONS OF UTILITIES, THAT ARE ABANDONED IN PLACE SHALL BE REMOVED BY THE CONTRACTOR TO THE EXTENT NECESSARY TO ACCOMPLISH THE WORK. THE CONTRACTOR SHALL FILL COMPLETELY THE REMAINING PORTION(S) OF ABANDONED UTILITIES WITH CONTROLLED LOW-STRENGTH MATERIALS (CLSM) OR GROUT, PER COUNTY REQUIREMENTS.
- TOPOGRAPHIC SURVEY BY HARPER HOUF PETERSON RIGHELLIS, INC. DATED DECEMBER 7, 2021. CONTRACTOR SHALL VERIFY ALL FIELD CONDITIONS PRIOR TO CONSTRUCTION.
- THE CONTRACTOR SHALL CONFINE ALL CONSTRUCTION ACTIVITIES TO THE PUBLIC RIGHT-OF-WAY AND EASEMENTS IDENTIFIED ON THE PLANS UNLESS WRITTEN PERMISSION IS OBTAINED FROM THE PROPERTY OWNER.
- ALL SURVEY MONUMENTS ON THE SUBJECT SITE, OR THAT MAY BE SUBJECT TO DISTURBANCE WITHIN THE CONSTRUCTION AREA, OR THE CONSTRUCTION OF ANY OFF-SITE IMPROVEMENTS SHALL BE ADEQUATELY REFERENCED AND PROTECTED PRIOR TO COMMENCEMENT OF ANY CONSTRUCTION ACTIVITY. IF THE SURVEY MONUMENTS ARE DISTURBED, MOVED, RELOCATED, OR DESTROYED AS A RESULT OF ANY CONSTRUCTION, THE PROJECT SHALL, AT IT'S COST, RETAIN THE SERVICES OF A PROFESSIONAL LAND SURVEYOR REGISTERED IN THE STATE OF OREGON TO RESTORE THE MONUMENT TO ITS ORIGINAL CONDITION AND FILE THE NECESSARY SURVEYS AS REQUIRED BY OREGON STATE LAW. A COPY OF ANY RECORDED SURVEY SHALL BE SUBMITTED TO COUNTY STAFF.

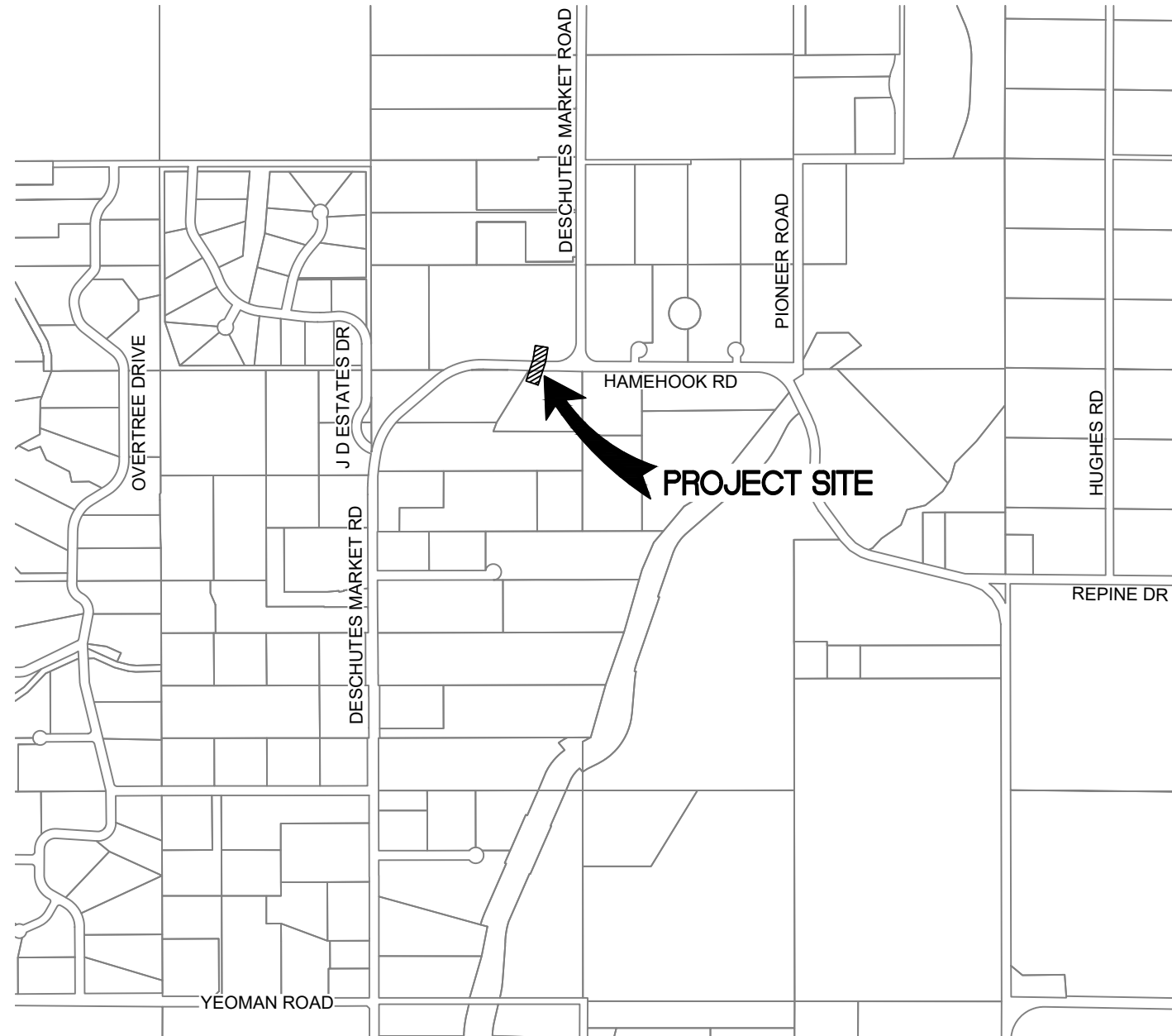

VICINITY MAP

SCALE: 1" = 1000'

OWNER & CLIENT:

DESCHUTES COUNTY
CONTACT: CODY SMITH, PE
61150 SE 27TH STREET
BEND, OR 97702
(541) 322-7113
cody.smith@deschutes.org

CIVIL ENGINEER & LAND SURVEYOR:

HARPER HOUF PETERSON RIGHELLIS INC.
CONTACT: NICOLAS SPEROS, PE
250 NW FRANKLIN AVENUE, SUITE 404
BEND, OR 97703
(541) 318-1161
nicolass@hhpr.com

C.O.I.D.

CENTRAL OREGON IRRIGATION DISTRICT
CONTACT: KELLEY HAMBY
1055 SW LAKE ROAD
REDMOND, OR 97756
(541) 548-6047
khamby@coid.org

LUMEN

LUMEN TECHNOLOGIES
CONTACT: JULIANA VAN SICKLE
2980 CROSBY AVENUE
KLAMATH FALLS, OR 97603
(541) 331-4136
juliana.vansickle@lumen.com

AVION WATER

AVION WATER COMPANY
CONTACT: MIKE HEFFERNAN
60813 PARRELL ROAD
BEND, OR 97702
(541) 382-5342
mike@avionwater.com

SHEET INDEX

C0.0	COVER SHEET
C0.1	NOTES
C1.0	C.O.I.D. CROSSING EXISTING CONDITIONS & DEMO PLAN
C2.0	C.O.I.D. CROSSING - PLAN AND PROFILE
C2.1	DESCHUTES MARKET RD - PLAN AND PROFILE
C3.0	DETAILS
C3.1	DETAILS

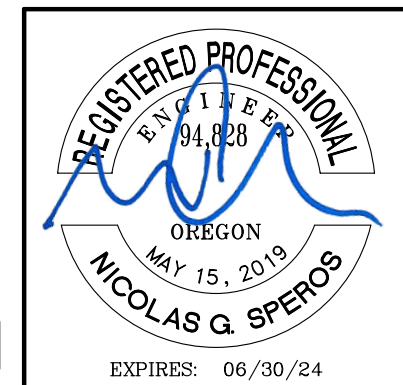
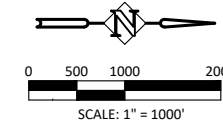

100% DESIGN

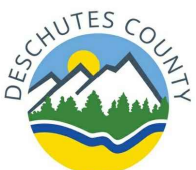

DATE	NO.	DESCRIPTION
R E V I S I O N S		

DESIGNED:	MD
DRAWN:	MD
CHECKED:	NS
DATE:	10.24.2022

HHPR Harper Houf Peterson Righellis Inc.
ENGINEERS * PLANNERS
LANDSCAPE ARCHITECTS * SURVEYORS
250 NW Franklin Ave, Suite 404, Bend, OR 97703
phone: 541.318.1161 www.hhpr.com fax: 541.318.1141

COVER SHEET
C.O.I.D. CANAL CROSSING IMPROVEMENTS - DESCHUTES MARKET RD
DESCHUTES COUNTY, OREGON

SHEET NO. C0.0
JOB NO. DC0-02

P:\03-Bend\DCO (Deschutes County)\DCO-02 (DMR Roundabout)\DCO02-DWG\Sheets\C.O.I.D. Crossing\DCO02-C0_C0ID Cover Sheet.dwg

FOUND MONUMENT TABLE				
POINT	NORTHING	EASTING	ELEVATION	DESCRIPTION
100	403137.32	3309127.22	3411.63	5/8" IR
101	403094.33	3309127.04	3412.59	HELD - 5/8" IR DOWN 0.75' IN PAVEMENT
102	403175.60	3308794.25	3413.45	R/R SPIKE
103	403141.42	3308463.74	3411.69	1" PIPE DOWN 0.5'
104	403081.20	3308628.00	3411.75	5/8" IR WITH YPC INSCRIBED "BAXTER"
105	403084.74	3308178.91	3416.07	1/2" IR
106	403219.09	3308103.29	3414.65	1/2" IR
107	403085.44	3307803.96	3413.06	1/2" IR
108	403272.47	3307757.54	3410.40	5/8" IR W/ 2" ALUMINUM CAP INSCRIBED "DESCHUTES COUNTY ENGINEERING R/W LS2390"
109	403280.13	3307748.38	3410.17	5/8" IR W/ YPC - ILLEGIBLE
110	403272.62	3307817.58	3410.16	5/8" IR W/ 2" ALUMINUM CAP INSCRIBED "DESCHUTES COUNTY ENGINEERING R/W LS2390"
111	403145.49	3307631.22	3413.40	5/8" IR W/ 2" ALUMINUM CAP INSCRIBED "DESCHUTES COUNTY ENGINEERING R/W LS2390"
112	403145.17	3307560.96	3413.97	5/8" IR W/ 2" ALUMINUM CAP INSCRIBED "DESCHUTES COUNTY ENGINEERING R/W LS2390"
113	403085.04	3307560.01	3413.94	5/8" IR W/ 2" ALUMINUM CAP INSCRIBED "DESCHUTES COUNTY ENGINEERING R/W LS2390"
114	403156.11	3307173.01	3414.50	5/8" IR W/ 2" ALUMINUM CAP INSCRIBED "DESCHUTES COUNTY ENGINEERING R/W LS2390"
115	403096.06	3307171.32	3415.06	5/8" IR W/ 2" ALUMINUM CAP INSCRIBED "DESCHUTES COUNTY ENGINEERING R/W LS2390"
117	403165.12	3307173.74	3414.19	5/8" IR W/ YPC INSCRIBED "HIGH DESERT ENG LS 540"
119	403090.63	3306903.19	3412.04	5/8" IR W/ YPC INSCRIBED "HIGH DESERT ENG LS 540"
120	403044.90	3306857.68	3412.88	5/8" IR W/ 2" ALUMINUM CAP INSCRIBED "DESCHUTES COUNTY ENGINEERING R/W LS2390"
121	402999.76	3306896.83	3414.54	1/2" IR
122	402999.23	3306896.61	3414.64	5/8" IR W/ 2" ALUMINUM CAP INSCRIBED "DESCHUTES COUNTY ENGINEERING R/W LS2390"
125	403753.76	3307756.76	N/A	5/8" IR W/ YPC INSCRIBED "LS 2527"
126	403803.73	3307756.62	3410.70	5/8" IR W/ YPC INSCRIBED "LS 2527"
127	404084.48	3307756.11	3407.60	5/8" IR W/ YPC INSCRIBED "LS 2527"
128	404389.04	3307819.04	3406.76	1.5" ALUMINUM CAP INSCRIBED "DESCHUTES CO REF MON"
129	404415.50	3307755.52	3406.74	5/8" IR W/ 2" ALUMINUM CAP INSCRIBED "DESCHUTES COUNTY ENGINEERING R/W LS2390"
131	403253.70	3308793.81	3412.25	1/2" IR
132	403144.03	3308103.03	3416.51	1/2" IR
133	403168.65	3308152.94	3414.52	1/2" IR
134	403143.76	3308152.80	3414.90	1/2" IR
135	403141.69	3308461.29	3412.04	1/2" IR
136	403102.15	3307778.57	3413.42	2.5" ALUMINUM CAP INSCRIBED "DESCHUTES RESET" IN MONUMENT BOX
137	403116.10	3307787.81	3414.65	2" ALUMINUM CAP - ILLEGIBLE - IN MONUMENT BOX
138	404415.57	3307794.19	3406.92	1/2" HOLE IN STEEL PLATE DOWN 0.7' IN PAVEMENT - UNDERLYING MONUMENT NOT TIED
139	404396.76	3307756.91	3406.24	1.5" ALUMINUM CAP INSCRIBED "DESCHUTES CO REF MON"
140	404458.48	3307758.76	3405.23	5/8" IR DOWN 0.5'
141	404511.85	3307806.06	3405.66	1.5" ALUMINUM CAP INSCRIBED "DESCHUTES CO REF MON"
400	403090.15	3306466.33	3414.10	5/8" IR W/ YPC INSCRIBED "HIGH DESERT ENG LS 540"
401	403139.73	3308745.49	3412.83	5/8" IR - DISTURBED
402	403139.46	3308793.62	3414.15	5/8" IR - DISTURBED
420	401763.95	3307803.01	3424.10	1/2" IR

C.O.I.D. PIPING SPECIFICATIONS

1. THE DISTRICT REQUIRES AN ENGINEERED PIPE PLAN, SPECIFICALLY, CONSTRUCTION DESIGN INCLUDING PLAN AND PROFILE VIEWS. PIPE SHALL MEET A MINIMUM 100 PSI PRESSURE REQUIREMENT. THE DISTRICT REQUIRED PIPE IS HDPE SDR 17 OR C-900/5 OR EQUIVALENT.
2. THE DISTRICT REQUIRES THE EASEMENT TO BE GRANTED TO THE DISTRICT, WITHOUT ANY RESERVATION, IN PERPETUITY.
3. CLEANOUTS ARE REQUIRED AT EVERY DEFLECTION ANGLE AND GREATER AND EVERY 250". DIAMETER OF RISER SHALL BE SAME DIAMETER AS MAIN LINE PIPE UNLESS OTHERWISE APPROVED BY COID.
4. IMPERVIOUS MATERIAL, (CLAY OR BENTONITE) TO BE PLACED AND COMPACTED WITH OPTIMUM MOISTURE AROUND THE INLET AND OUTLET STRUCTURES.
5. THERE SHALL BE A MINIMUM OF 18" OF SEPARATION BETWEEN COID PIPES AND ANY OTHER UTILITY.
6. TRENCH SECTION SHALL HAVE A MINIMUM OF 4" OF BEDDING AND SELECT MATERIAL SHALL CONTINUE TO A MINIMUM OF 12" OVER PIPE. SELECT MATERIAL SHALL BE ¾" MINUS GRAVEL MATERIAL AND A SAMPLE SHALL BE PROVIDED FOR APPROVAL.
7. 10 GAUGE TONING WIRE WILL BE INSTALLED ALONG THE ENTIRE REACH OF THIS PIPING PROJECT FOR LOCATION PURPOSES.
8. 2" WIDE "IRRIGATION" DETECTION TAPE WILL BE PLACED NO LOWER THAN 18" BELOW GRADE. A SECOND COURSE MAY BE REQUIRED DEPENDING ON PIPE DEPTH.
9. DOCUMENTATION VERIFYING OWNERSHIP OF PARCEL WHERE PIPING IS TO TAKE PLACE IS REQUIRED PRIOR TO PIPING.
10. ALL PIPING FEES WILL BE WAIVED FOR DESCHUTES COUNTY. INSPECTION OF INSTALLATION SHALL BE THE RESPONSIBILITY OF THE DEVELOPER/OWNER.
11. IT IS THE RESPONSIBILITY OF THE DEVELOPER/OWNER TO OBTAIN THE PROPER LICENSES AND MAKE SURE ALL ASSOCIATED FEES ARE PAID PRIOR TO THE START OF EXCAVATION.
12. ALL WORK IS SCHEDULED WITH THE DISTRICT SO AS NOT TO INTERFERE WITH THE MONTHLY STOCK WATER RUNS AND COMPLETED PRIOR TO APRIL 1.
13. THERE SHALL BE NO ENCROACHMENTS TO THE COID EASEMENT WITHOUT A PERMIT FROM THE COID OFFICE.
14. ANY CROSSINGS OF THE COID EASEMENT SHALL BE BY PERMIT ONLY AND SHALL BE RECORDED AT THE DISTRICT'S OFFICE FOR INSTRUCTIONS AND ASSOCIATED FEES.
15. NO STRUCTURES, FENCES, TREES OR SHRUBS, CONCRETE, OR ASPHALT WILL BE PERMITTED WITHIN THE EASEMENT. EXISTING STRUCTURES OR IMPROVEMENTS ARE SUBJECT TO REMOVAL OR DESTRUCTION IF THEY MAY IMPEDE DISTRICT MAINTENANCE/REPAIR RESPONSIBILITIES. IF STRUCTURES OR IMPROVEMENTS ARE INSTALLED, IT WILL BE WITH THE UNDERSTANDING THAT IF ANY DAMAGE OCCURS DURING MAINTENANCE TO OR REPLACEMENT OF THE PIPE, THE DISTRICT WILL NOT BE HELD LIABLE.

VERTICAL DATUM

ELEVATION DATUM: NGVD29
 BASED ON MULTIPLE AVERAGED GPS
 OBSERVATIONS UTILIZING THE OREGON
 REAL TIME GPS NETWORK (ORGN)

HORIZONTAL DATUM

HORIZONTAL DATUM IS NAD83
 (ADJUSTMENT 1991) EXPRESSED AS
 CENTRAL OREGON COORDINATE SYSTEM
 (COCS), ESTABLISHED FROM MULTIPLE
 AVERAGED GPS OBSERVATIONS.

BASIS OF BEARINGS

CENTRAL OREGON
 COORDINATE SYSTEM



100% DESIGN

P:\03-Bend\DCO (Deschutes County)\DCO-02 (DMR Roundabout)\DCO02-DWGS\Sheets\C.O.I.D. Crossing\DCO02-CO_COID Cover Sheet.dwg



DATE	NO.	DESCRIPTION
R E V I S I O N S		

DESIGNED:	MD
DRAWN:	MD
CHECKED:	NS
DATE:	10.24.2022

HHPR Harper Houf Peterson Righellis Inc.
 ENGINEERS * PLANNERS
 LANDSCAPE ARCHITECTS * SURVEYORS
 250 NW Franklin Ave, Suite 404, Bend, OR 97703
 phone: 541.318.1161 www.hhpr.com fax: 541.318.1141

NOTES
C.O.I.D. CANAL CROSSING IMPROVEMENTS - DESCHUTES MARKET RD
 DESCHUTES COUNTY, OREGON

SHEET NO.
C0.1
 JOB NO.
 DCO-02

EXPIRES: 06/30/24

P:\03-Bend\DCO (Deschutes County)\DCO-02 (DMR Roundabout)\DCO02-DWG\Sheets\C.O.I.D. Crossing\DCO02-C1 - C.O.I.D. Demo.dwg

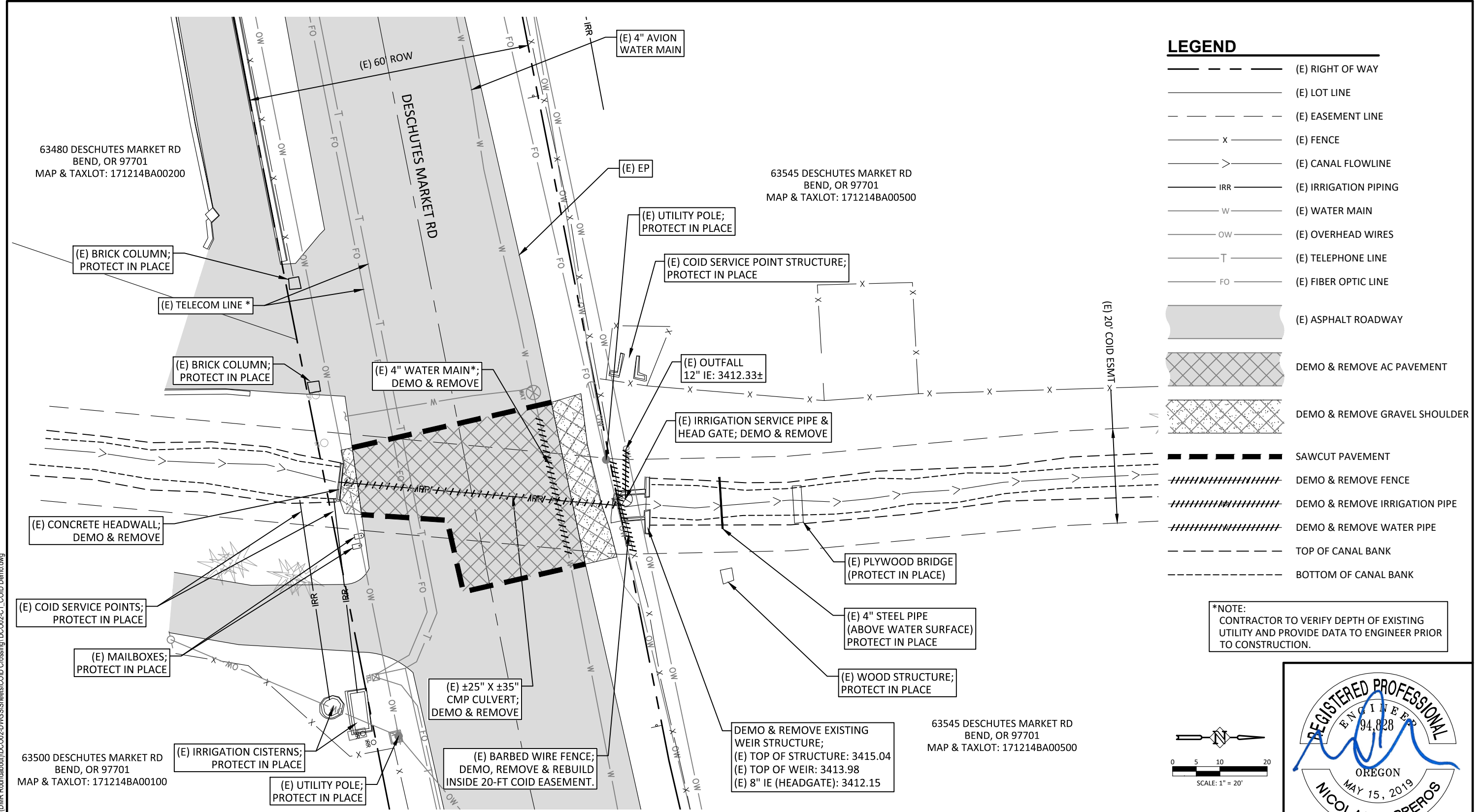

63480 DESCHUTES MARKET RD
BEND, OR 97701
MAP & TAXLOT: 171214BA00200

63545 DESCHUTES MARKET RD
BEND, OR 97701
MAP & TAXLOT: 171214BA00500

63500 DESCHUTES MARKET RD
BEND, OR 97701
MAP & TAXLOT: 171214BA00100

63545 DESCHUTES MARKET RD
BEND, OR 97701
MAP & TAXLOT: 171214BA00500

- LEGEND**
- (E) RIGHT OF WAY
 - (E) LOT LINE
 - - - (E) EASEMENT LINE
 - x (E) FENCE
 - > (E) CANAL FLOWLINE
 - IRR (E) IRRIGATION PIPING
 - W (E) WATER MAIN
 - OW (E) OVERHEAD WIRES
 - T (E) TELEPHONE LINE
 - FO (E) FIBER OPTIC LINE
 - [Hatched Box] (E) ASPHALT ROADWAY
 - [Cross-hatched Box] DEMO & REMOVE AC PAVEMENT
 - [Diagonal-hatched Box] DEMO & REMOVE GRAVEL SHOULDER
 - [Thick Dashed Line] SAWCUT PAVEMENT
 - [Hatched Line] DEMO & REMOVE FENCE
 - [Hatched Line] DEMO & REMOVE IRRIGATION PIPE
 - [Hatched Line] DEMO & REMOVE WATER PIPE
 - - - TOP OF CANAL BANK
 - - - BOTTOM OF CANAL BANK

*NOTE:
CONTRACTOR TO VERIFY DEPTH OF EXISTING
UTILITY AND PROVIDE DATA TO ENGINEER PRIOR
TO CONSTRUCTION.

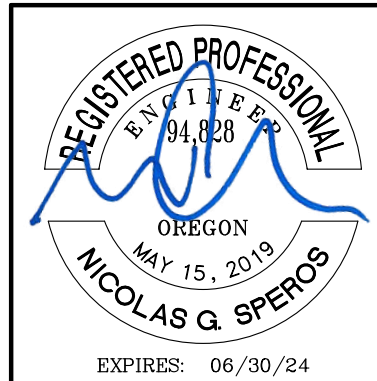
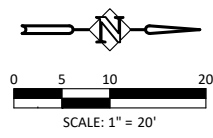

C.O.I.D. CROSSING EXISTING CONDITIONS & DEMOLITION PLAN

SCALE: 1" = 20'

100% DESIGN

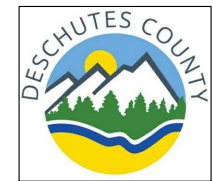

DATE	NO.	DESCRIPTION
REVISIONS		

DESIGNED:	MD
DRAWN:	MD
CHECKED:	NS
DATE:	10.24.2022

HHPR Harper Houf Peterson Righellis Inc.
ENGINEERS * PLANNERS
LANDSCAPE ARCHITECTS * SURVEYORS
250 NW Franklin Ave., Suite 404, Bend, OR 97703
phone: 541.318.1161 www.hhpr.com fax: 541.318.1141

EXISTING CONDITIONS & DEMOLITION PLAN
C.O.I.D. CANAL CROSSING IMPROVEMENTS - DESCHUTES MARKET RD
DESCHUTES COUNTY, OREGON

SHEET NO.
C1.0
JOB NO.
DCO-02

63480 DESCHUTES MARKET RD
BEND, OR 97701
MAP & TAXLOT: 171214BA00200

63500 DESCHUTES MARKET RD
BEND, OR 97701
MAP & TAXLOT: 171214BA00100

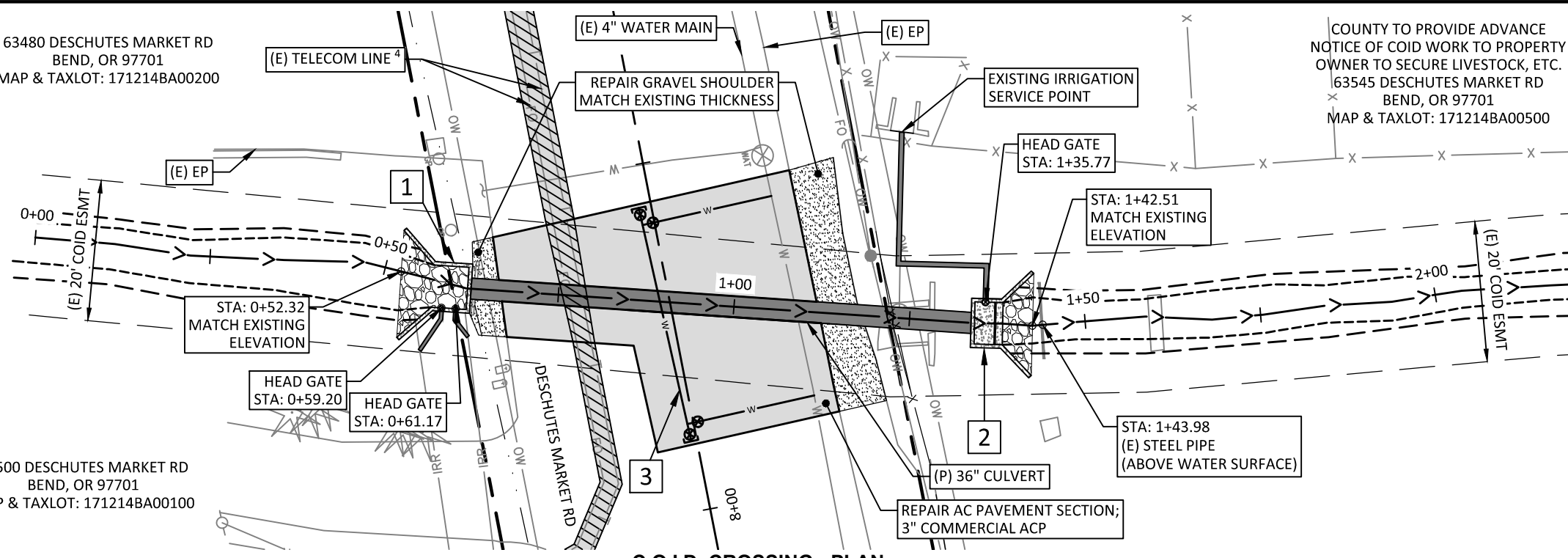

C.O.I.D. CROSSING - PLAN
SCALE: 1" = 20'

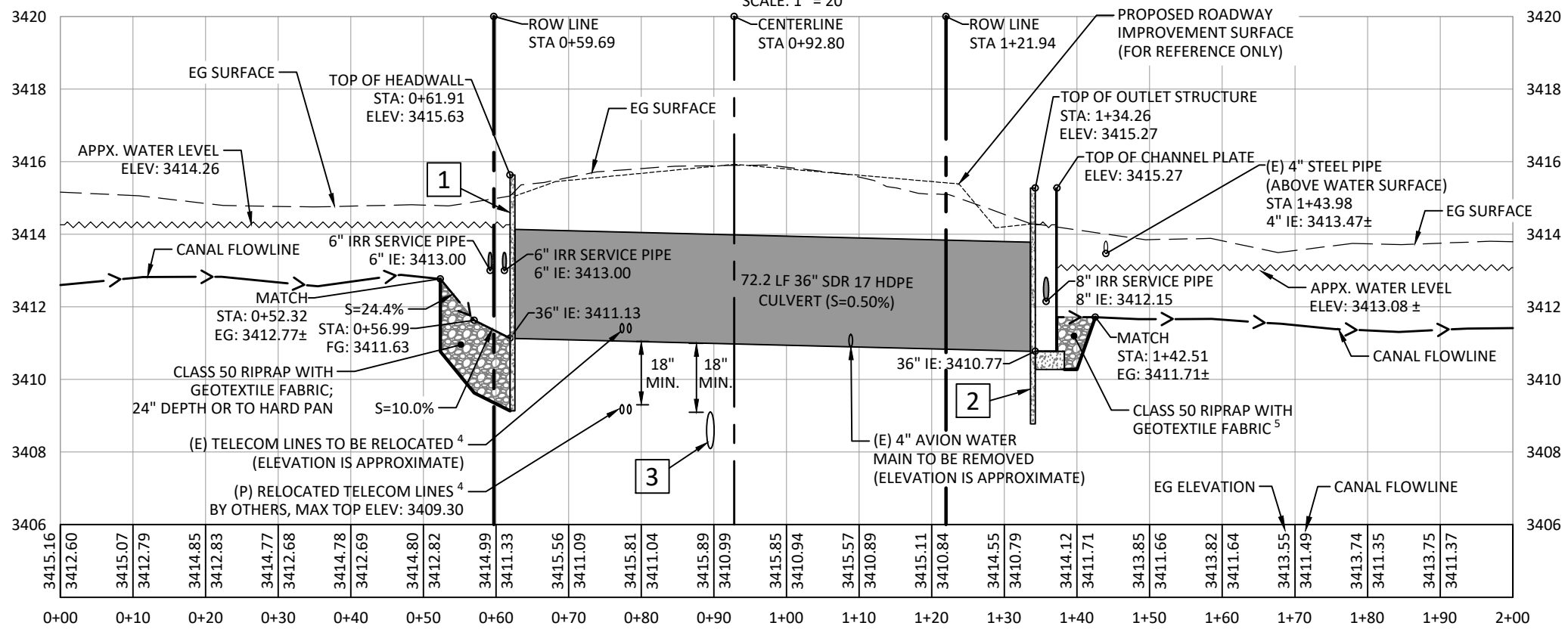

C.O.I.D. CROSSING - PROFILE
SCALE: 1" = 20' (HORIZ.)
1" = 4' (VERT.)

C.O.I.D. CROSSING CONSTRUCTION NOTES:

- 1 STA 0+61.91, 0.0' (COID CANAL FLOWLINE)
CONSTRUCT CONCRETE INLET STRUCTURE WITH 2 - 6" HEAD GATES ON THE EAST FACE PER DETAIL ON SHEET C3.0; HEAD GATE INSTALLATION TO BE PERFORMED BY COID (CONTRACTOR TO COORDINATE SCHEDULING)
6" IE-OUT (E) (STA 0+59.20): 3412.98
CONSTRUCT 7.0 LF 6" HDPE PIPE AND CONNECT TO EXISTING IRRIGATION SERVICE POINT.
6" IE-OUT (E) (STA 0+61.17): 3413.00
CONSTRUCT 4.6 LF 6" HDPE PIPE AND CONNECT TO EXISTING IRRIGATION SERVICE POINT.
36" IE-OUT (N): 3411.13
CONSTRUCT 72.2 LF 36" SDR 17 HDPE PIPE (S=0.50%) PER COID STANDARDS TO CONCRETE OUTLET STRUCTURE. (SEE NOTE 2)
- 2 STA 1+34.26, 0.0' (COID CANAL FLOWLINE)
CONSTRUCT CONCRETE OUTLET STRUCTURE WITH CHANNEL IRON AND 8" HEAD GATE ON WEST FACE PER DETAIL ON SHEET C3.0; HEAD GATE INSTALLATION TO BE PERFORMED BY COID (CONTRACTOR TO COORDINATE SCHEDULING)
TOP OF CHANNEL PLATE: 3415.27
36" IE-IN (S): 3410.77
8" IE-OUT (W) (STA 1+35.77): 3412.15±
CONSTRUCT 36.0 LF 8" HDPE PIPE AND RECONNECT TO EXISTING IRRIGATION SERVICE POINT.
- 3 PROPOSED 12" AVION WATER MAIN.
SEE SHEET C2.1 FOR MORE INFORMATION.

- *NOTES:**
1. CONTRACTOR TO WORK WITHIN EXISTING COID EASEMENT LIMITS ON TAXLOTS 171214BA00500 & 171214BA00200 AND COUNTY RIGHT-OF-WAY.
 2. ALL IRRIGATION PIPE SHALL BE MECHANICALLY RESTRAINED.
 3. CONTRACTOR SHALL COORDINATE WITH COID CONCERNING TIMING OF STOCK WATER RUNS.
 4. CONTRACTOR TO VERIFY DEPTH OF EXISTING UTILITY AND PROVIDE DATA TO ENGINEER PRIOR TO CONSTRUCTION. SEE CONSTRUCTION NOTE 2 ON SHEET C2.1
 5. INSTALL RIPRAP AS NEEDED TO CREATE A FLUSH TRANSITION FROM CONCRETE FLOOR TO CANAL FLOWLINE

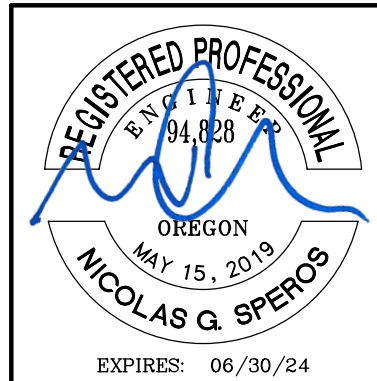
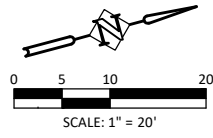

100% DESIGN



DATE	NO.	DESCRIPTION
REVISIONS		

DESIGNED:	MD
DRAWN:	MD
CHECKED:	NS
DATE:	10.24.2022

HHPR Harper Houf Peterson Righellis Inc.
ENGINEERS * PLANNERS
LANDSCAPE ARCHITECTS * SURVEYORS
250 NW Franklin Ave., Suite 404, Bend, OR 97703
phone: 541.318.1161 www.hhpr.com fax: 541.318.1141

COID CROSSING - PLAN & PROFILE
C.O.I.D. CANAL CROSSING IMPROVEMENTS - DESCHUTES MARKET RD
DESCHUTES COUNTY, OREGON

C2.0

JOB NO. DC0-02

P:\03-Bend\DCO (Deschutes County)\DCO-02 (DMR Roundabout)\DCO02-DWGS\Sheets\C.O.I.D Crossing\DCO02-C2_C.O.I.D Plan & Profile.dwg

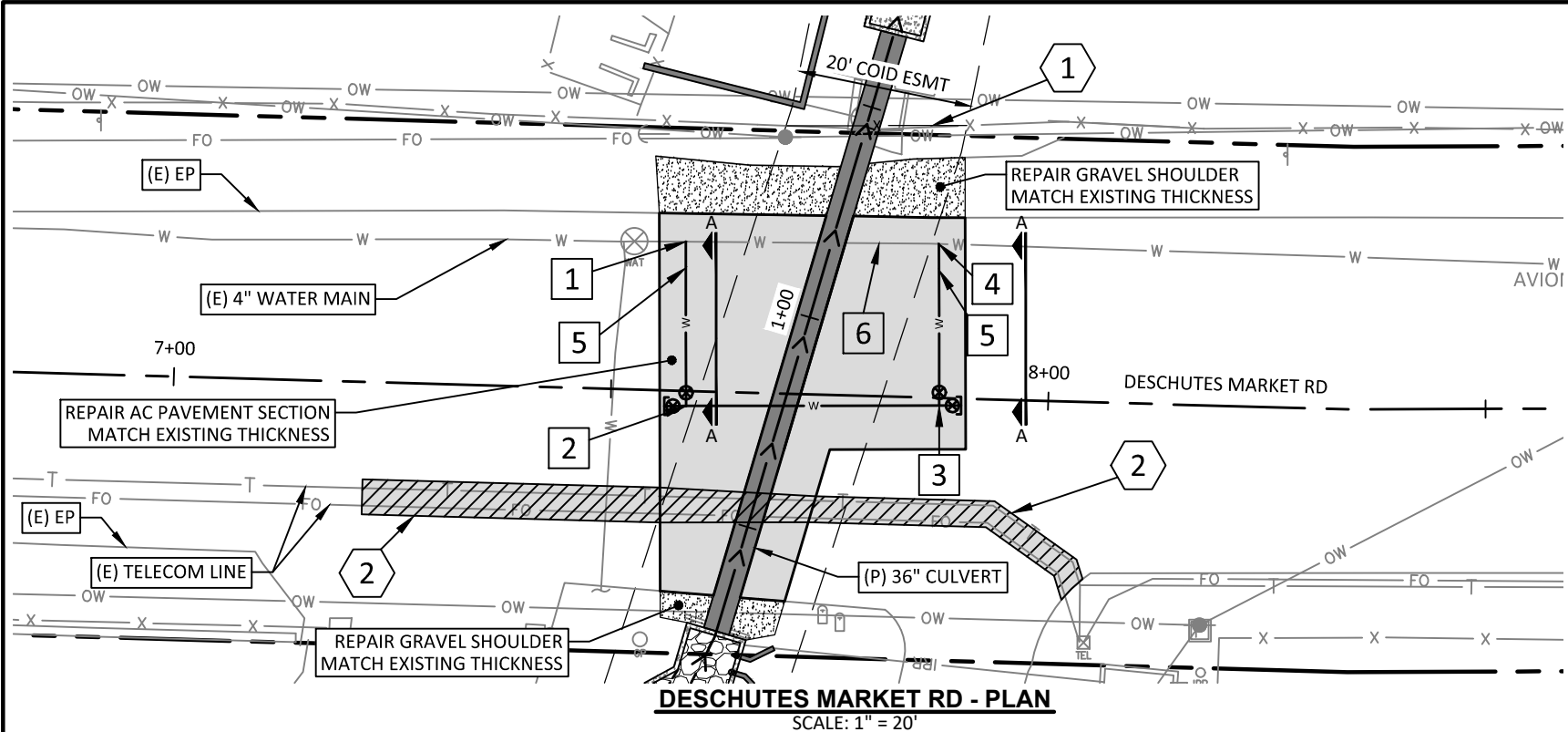

WATER MAIN CONSTRUCTION NOTES:

- 1** STA 7+58.06, 17.0' L (DESCHUTES MARKET RD) CUT EXSTING 4" WATER MAIN; INSTALL 1 - 4" 90° BEND WITH JOINT RESTRAINT, ROTATED 45° DOWNWARD (SEE 4" CONNECTION DETAIL, THIS SHEET); CONSTRUCT 18.8 LF 4" D.I. WATER PIPE (FULLY RESTRAINED) PER AVION STANDARDS AND SPECIFICATIONS TO 12" TEE. RESTRAIN EXISTING 4" PIPE AS NECESSARY. SEE NOTE 2.
- 2** STA 7+58.62, 1.7' R (DESCHUTES MARKET RD) INSTALL 1 - 12" x 4" TEE, 12" IE 3408.10:
NORTH LEG: INSTALL 1 - 4" G.V. ASSEMBLY;
WEST LEG: INSTALL 1 - 12" G.V. ASSEMBLY; 1 - 12" PLUG FOR FUTURE EXTENSION.
EAST LEG: CONSTRUCT 32.0 LF 12" D.I. WATER PIPE (FULLY RESTRAINED) PER AVION STANDARDS AND SPECIFICATIONS TO 12" TEE. SEE NOTE 3.
- 3** STA 7+87.56, 0.9' R (DESCHUTES MARKET RD) INSTALL 1 - 12" x 4" TEE, 12" IE 3408.10:
NORTH LEG: INSTALL 1 - 4" G.V. ASSEMBLY; CONSTRUCT 18.5 LF 4" D.I. WATER PIPE (FULLY RESTRAINED) PER AVION STANDARDS AND SPECIFICATIONS TO 4" BEND. SEE NOTE 4.
WEST LEG: SEE NOTE 2 (EAST LEG)
EAST LEG: INSTALL 1 - 12" G.V. ASSEMBLY; 1 - 12" PLUG FOR FUTURE EXTENSION.
- 4** STA 7+87.01, 17.6' L (DESCHUTES MARKET RD) CUT EXISTING 4" WATER MAIN; INSTALL 1 - 4" 90° BEND WITH JOINT RESTRAINT, ROTATED 45° DOWNWARD (SEE 4" CONNECTION DETAIL, THIS SHEET); CONNECT TO EXISTING 4" WATER MAIN. RESTRAIN EXISTING 4" PIPE AS NECESSARY.
- 5** STA 7+58.15, 14.0' L & STA 7+87.10, 14.6' L (DESCHUTES MARKET RD) CHLORINATE AND PRESSURE TEST PER AVION WATER DETAIL "HOT STICK CONNECTION AFTER FLUSHING". SEE SHEET C3.1 FOR DETAIL.
- 6** STA 7+58.06, 17.0' L TO 7+87.01, 17.6' L (DESCHUTES MARKET RD) DEMO AND REMOVE EXISTING 4" WATER MAIN.

***NOTES:**

- 1. CONTRACTOR TO WORK WITHIN EXISTING COID EASEMENT LIMITS ON TAXLOTS 171214BA00500 & 171214BA00200 AND COUNTY RIGHT-OF-WAY.
- 2. ALL IRRIGATION PIPE SHALL BE MECHANICALLY RESTRAINED.
- 3. CONTRACTOR SHALL COORDINATE WITH COID CONCERNING TIMING OF STOCK WATER RUNS.
- 4. CONTRACTOR TO VERIFY DEPTH OF EXISTING UTILITY AND PROVIDE DATA TO ENGINEER PRIOR TO CONSTRUCTION.

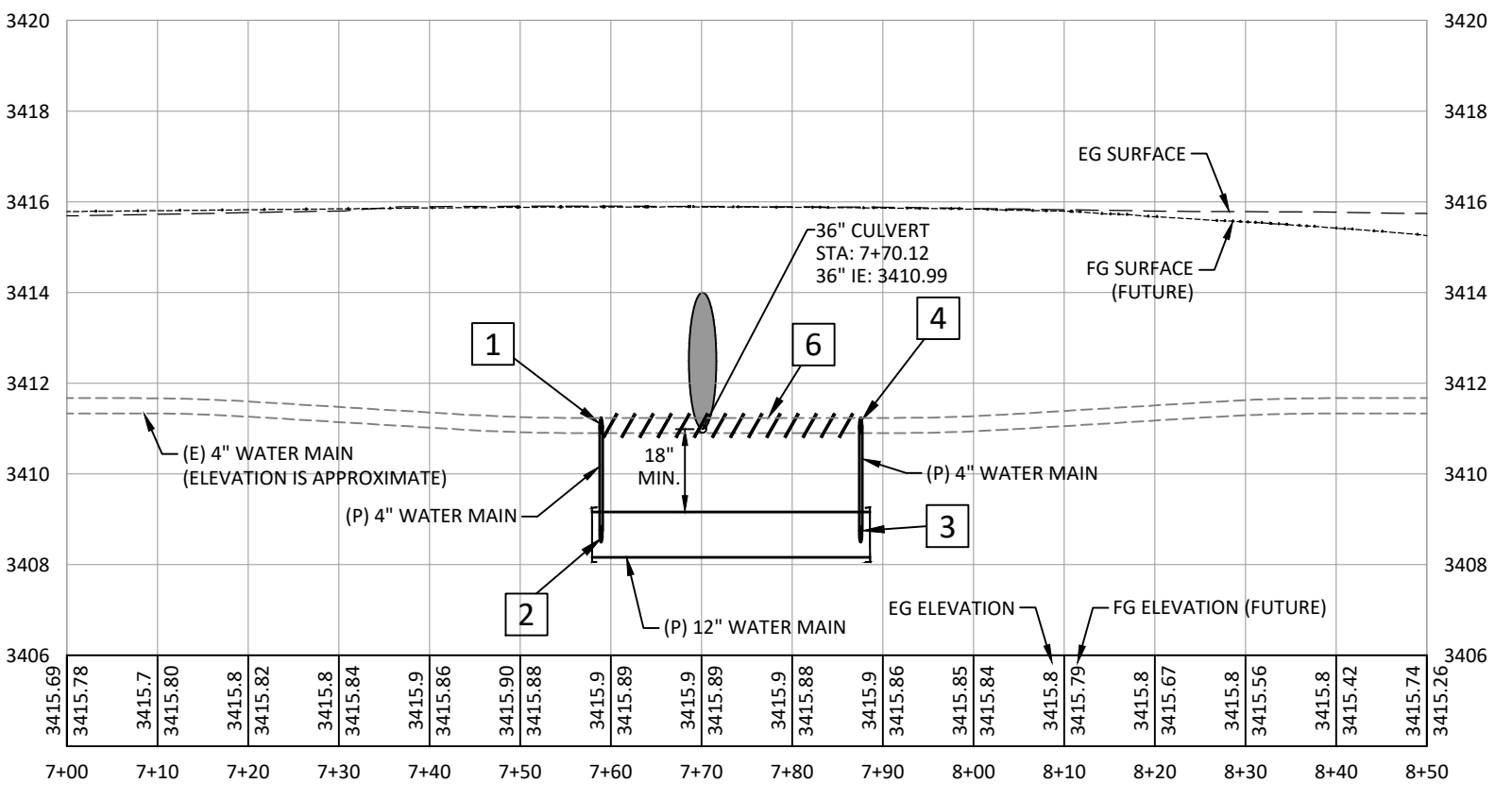

CONSTRUCTION NOTES:

- 1** STA 7+69.17, 30.6 L TO 7+89.83, 31.2' L (DESCHUTES MARKET RD) INSTALL BARBED WIRE FENCE PER DETAIL ON SHEET C3.1.
- 2** APPROXIMATE LIMITS OF SAWCUT, TRENCHING AND PAVEMENT RESTORATION FOR TELECOM RELOCATION. ALL WORK TO BE DONE BY LUMEN CONTRACTOR AFTER EXISTING COID CULVERT IS REMOVED. COUNTY CONTRACTOR TO PROVIDE LUMEN CONTRACTOR ONE DAY TO COMPLETE WORK. COUNTY CONTRACTOR TO COORDINATE SCHEDULING WITH LUMEN AND PROVIDE MINIMUM 14-DAY NOTICE.

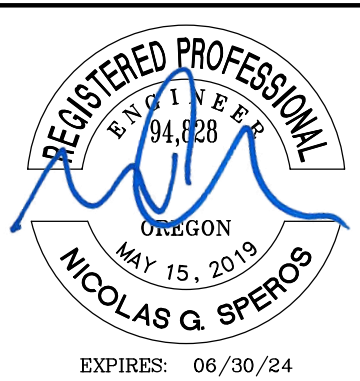
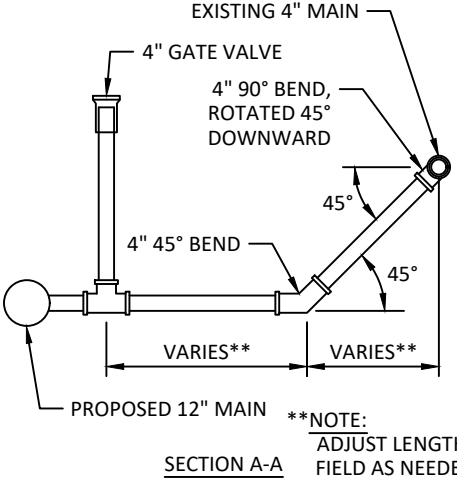

100% DESIGN



DATE	NO.	DESCRIPTION
REVISIONS		

DESIGNED:	MD
DRAWN:	MD
CHECKED:	NS
DATE:	10.24.2022

HHPR Harper Houf Peterson Righellis Inc.
 ENGINEERS * PLANNERS
 LANDSCAPE ARCHITECTS * SURVEYORS
 250 NW Franklin Ave., Suite 404, Bend, OR 97703
 phone: 541.318.1161 www.hhpr.com fax: 541.318.1141

DESCHUTES MARKET RD - PLAN & PROFILE
C.O.I.D. CANAL CROSSING IMPROVEMENTS - DESCHUTES MARKET RD
 DESCHUTES COUNTY, OREGON

SHEET NO. **C2.1**
 JOB NO. DCO-02

P:\03-Bend\DCO (Deschutes County)\DCO-02 (DMR Roundabout)\DCO02-DWG\SS\Sheets\C3.0_COID Details.dwg

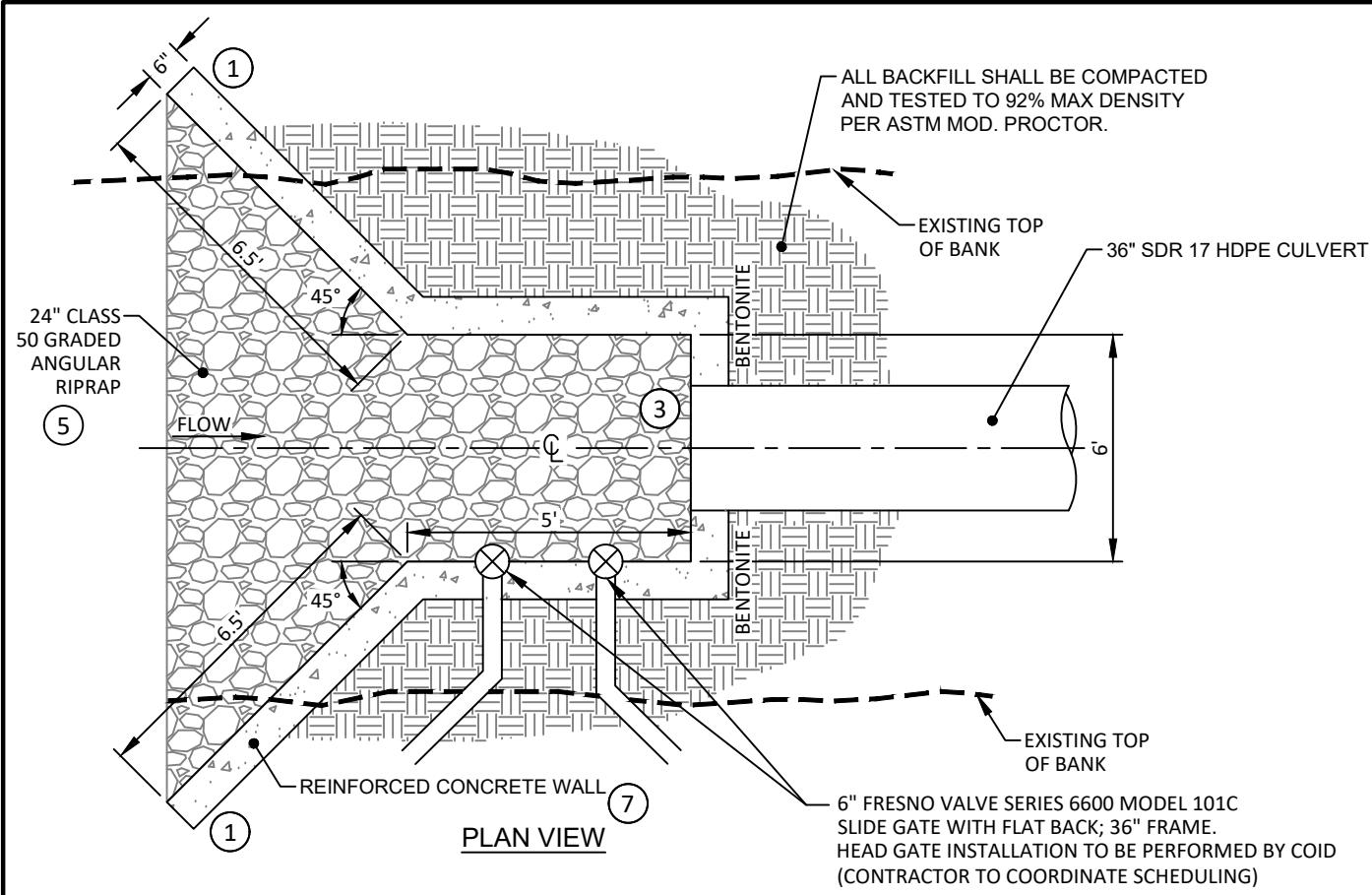

PLAN VIEW

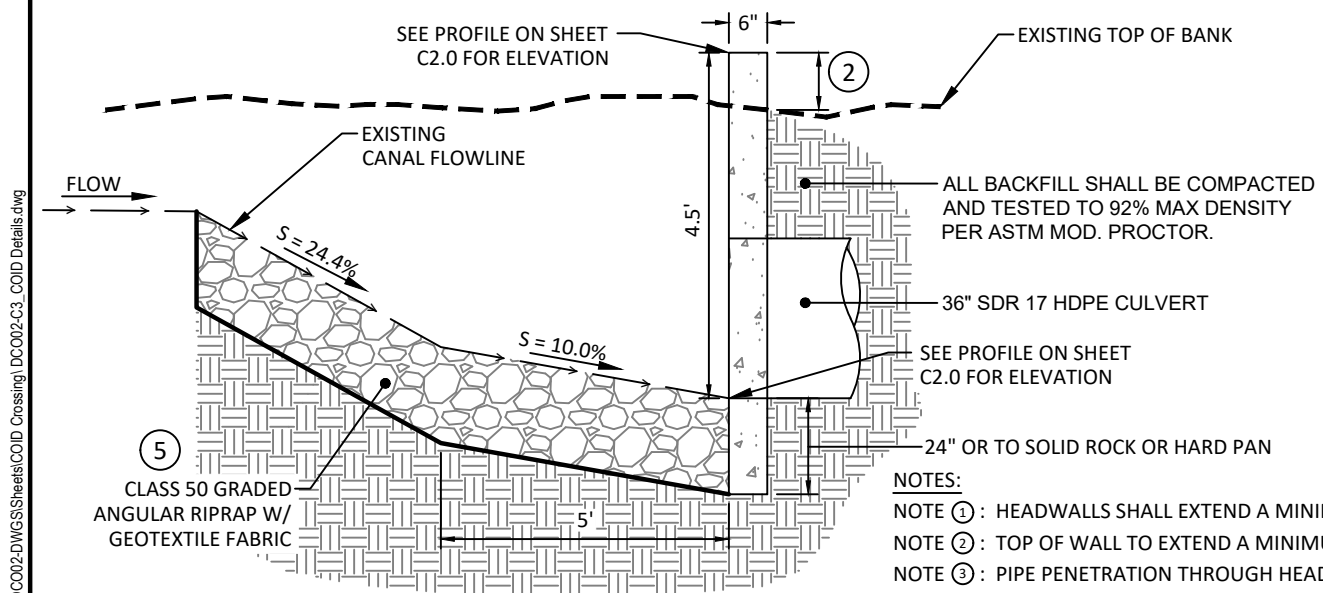

PROFILE VIEW

CONCRETE INLET STRUCTURE DETAIL

NTS

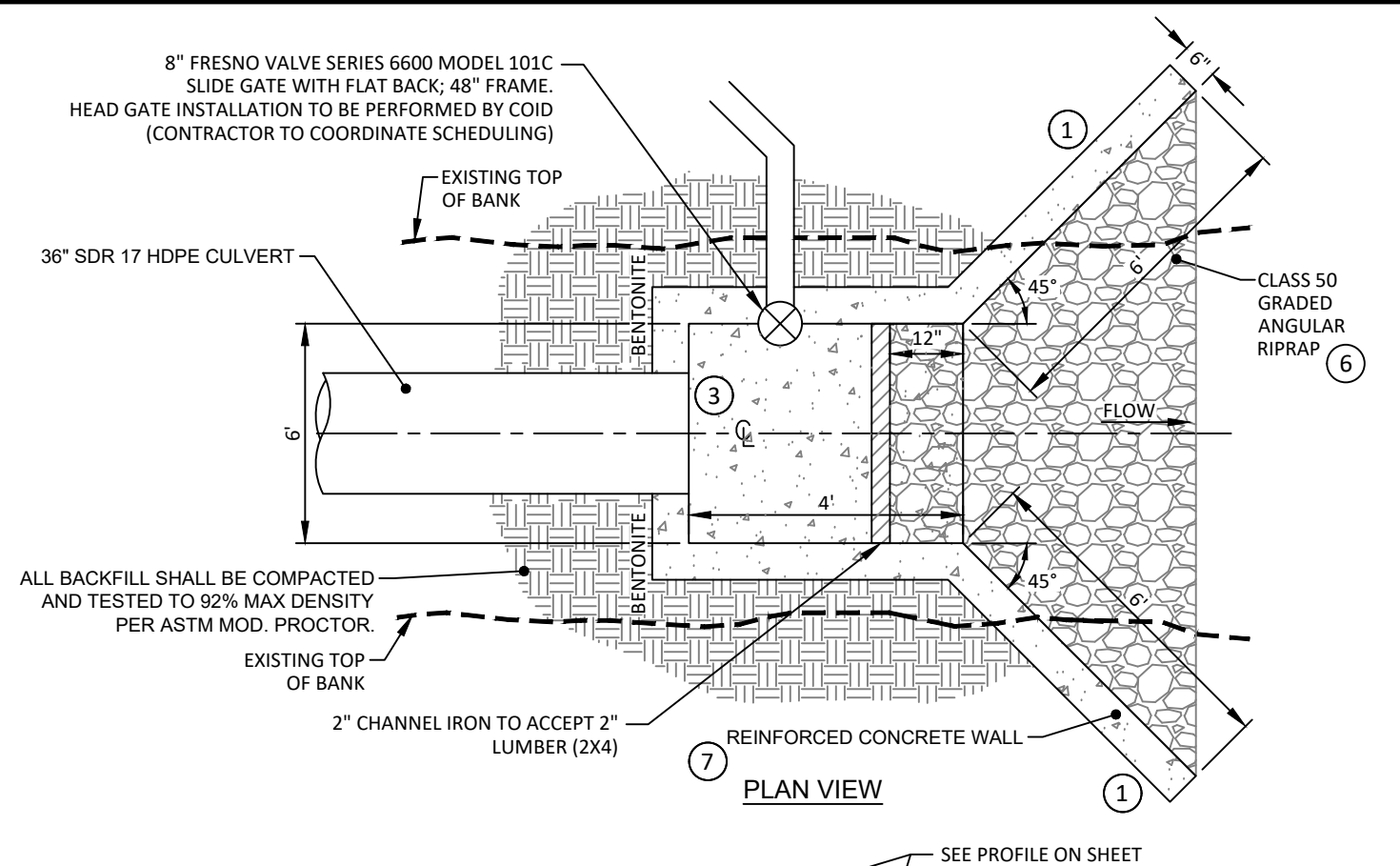

PLAN VIEW

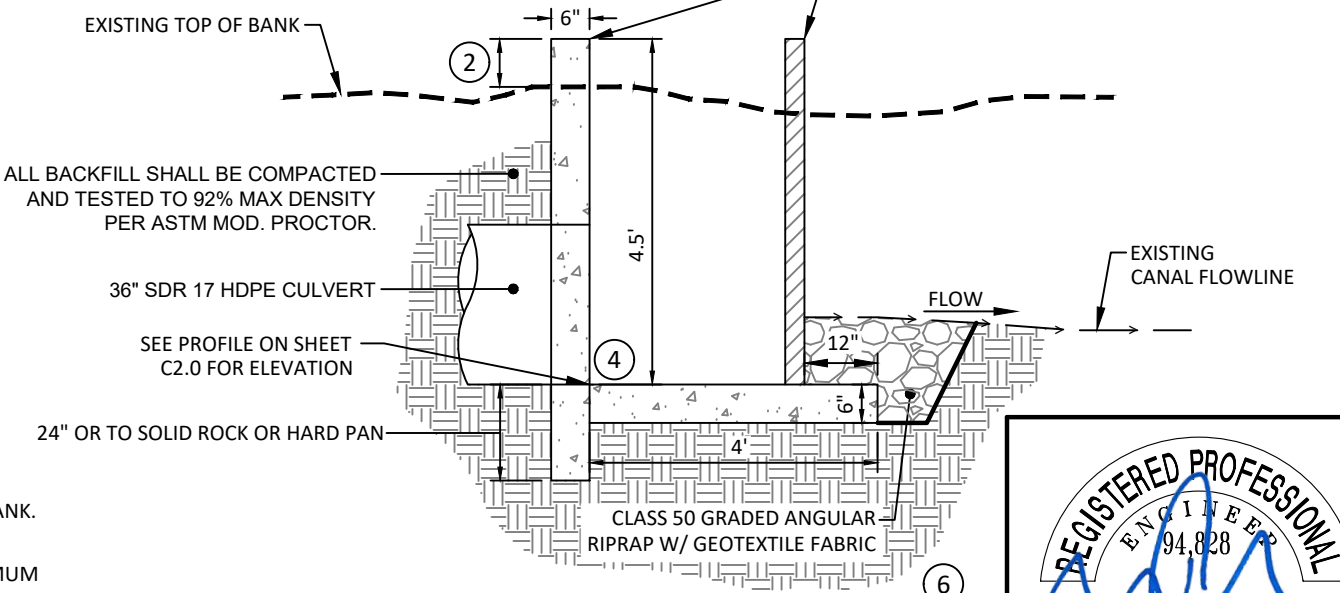

PROFILE VIEW

CONCRETE OUTLET STRUCTURE DETAIL

NTS

100% DESIGN

NOTES:

- NOTE ① : HEADWALLS SHALL EXTEND A MINIMUM OF 3 FEET INTO CANAL BANK.
- NOTE ② : TOP OF WALL TO EXTEND A MINIMUM OF 6" ABOVE CANAL BANK.
- NOTE ③ : PIPE PENETRATION THROUGH HEADWALL SHALL INCLUDE A MINIMUM 1" x 1" HDPE SEEP RING CENTERED IN THE HEADWALL AT EACH END.
- NOTE ④ : CONCRETE FLOOR TIED TO WALL. FLOOR TO BE 6" DEPTH REINFORCED WITH #4 BARS 12" O.C. EACH WAY.
- NOTE ⑤ : CONTRACTOR TO COORDINATE WITH C.O.I.D. PRIOR TO RIPRAP INSTALLATION TO DETERMINE IF RIPRAP IS NEEDED, BASED ON CONDITIONS PRESENT IN THE FIELD.
- NOTE ⑥ : INSTALL RIPRAP AS NEEDED TO CREATE A FLUSH TRANSITION FROM WEIR GATE TO CANAL FLOWLINE.
- NOTE ⑦ : REINFORCE CONCRETE WALL WITH #4 BARS 12" O.C. EACH WAY.

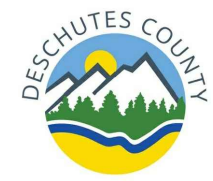
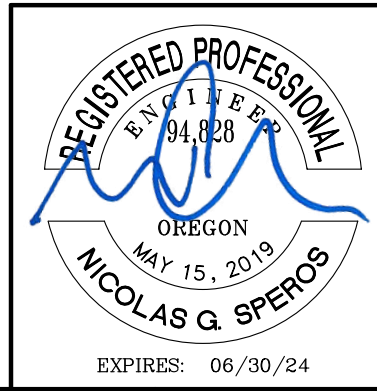

DATE	NO.	DESCRIPTION
REVISIONS		

DESIGNED:	MD
DRAWN:	MD
CHECKED:	NS
DATE:	10.24.2022

HHPR Harper Houf Peterson Righellis Inc.
 ENGINEERS*PLANNERS
 LANDSCAPE ARCHITECTS*SURVEYORS
 250 NW Franklin Ave., Suite 404, Bend, OR 97703
 phone: 541.318.1161 www.hhpr.com fax: 541.318.1141

DETAILS
C.O.I.D. CANAL CROSSING IMPROVEMENTS - DESCHUTES MARKET RD
 DESCHUTES COUNTY, OREGON

SHEET NO. **C3.0**
 JOB NO. DCO-02

**AVION WATER CO
FULL SEPARATION CHLORINATION
Hot Stick Chlorination Detail**

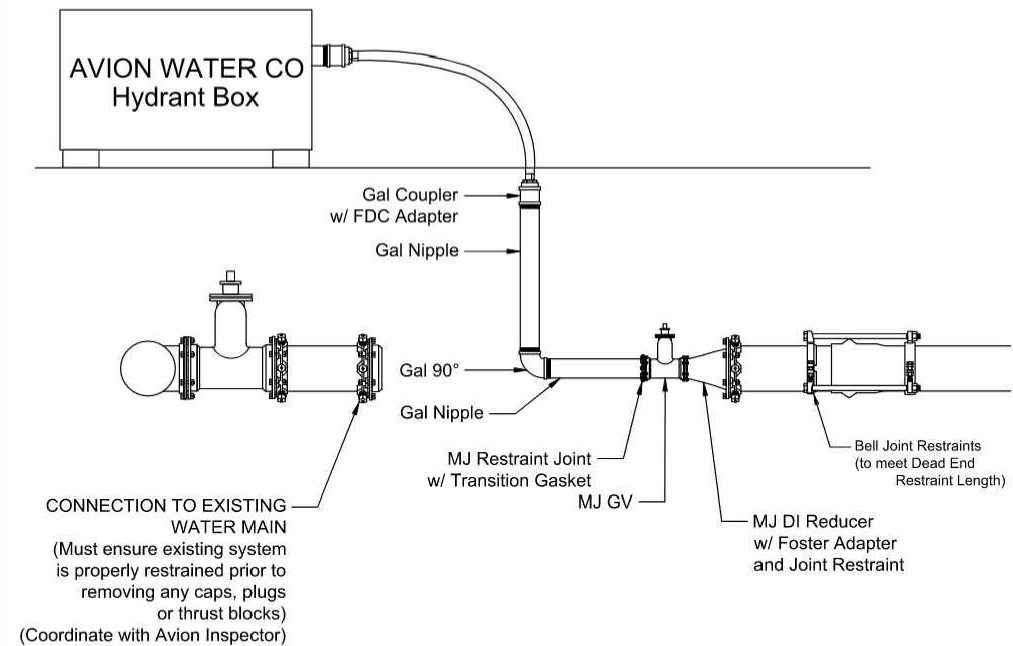

TESTING AND FLUSHING
Flushing needs to meet AWWA Standards (3.0ft/sec)
4"-10" Mainline - May use (1) 2 1/2" Hydrant Port and (1) Hydrant Box
12"-16" Mainline - May use (2) 2 1/2" Hydrant Ports and (2) Hydrant Boxes
Any Mainline 18" and above or any proposed flushing variation must be verified by Avion Water Inspector



DWN BY: TEL	Avion design specifications do not relieve the developer, engineer, or contractor from responsibility to design and construct the water system in accordance with good engineering and construction practices. Must adhere to DAR 333-061-0050 Construction Standards.	AVION WATER CO 60813 PARRELL RD BEND, OR 97702	NOT TO SCALE
DATE: JAN 2022			REV/DATE REV/DATE REV/DATE
		HOT STICK CONNECTION AFTER FLUSHING Pipe and sleeves to be hand chlorinated	

**AVION WATER CO, INC.
GENERAL TRENCH DETAIL**

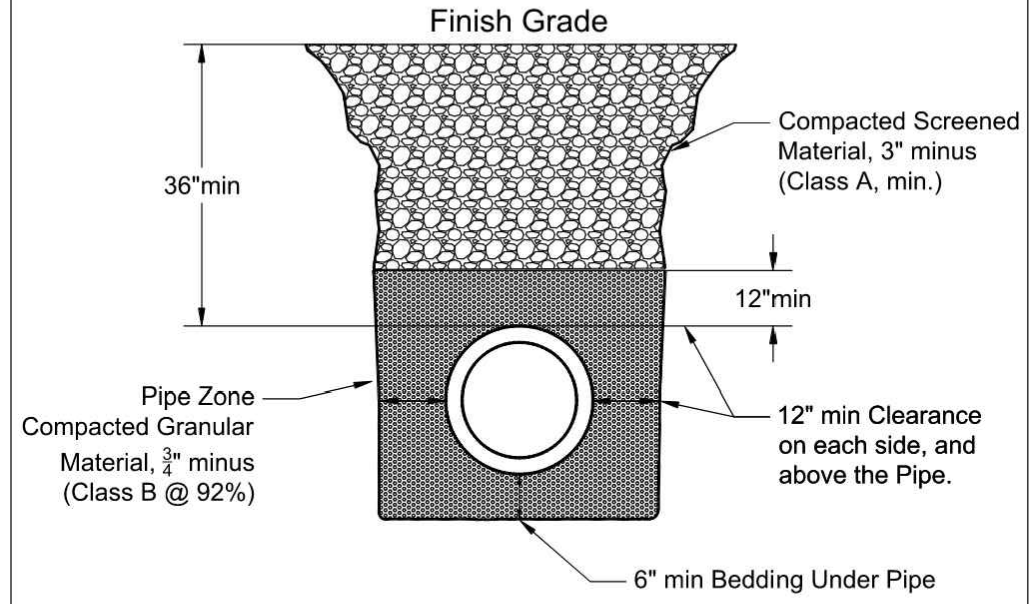

- NOTES:**
- MUST ADHERE TO CITY AND COUNTY ROW SPECIFICATIONS, when applicable.
 - Pipe bedded in compact granular material to the centerline of the pipe, 6" minimum under the pipe.
 - Compacted granular material, 12" above top of pipe.
 - Compaction testing shall be performed at the top of pipe zone, 12" min above waterline. Compaction testing shall meet 92% and tested every 100ft.

DWN BY: TEL	Avion design specifications do not relieve the developer, engineer, or contractor from responsibility to design and construct the water system in accordance with good engineering and construction practices. Must adhere to DAR 333-061-0050 Construction Standards.	AVION WATER CO 60813 PARRELL RD BEND, OR 97702	NOT TO SCALE
DATE: April 2022			REV/DATE REV/DATE REV/DATE
		GENERAL TRENCH DETAIL	

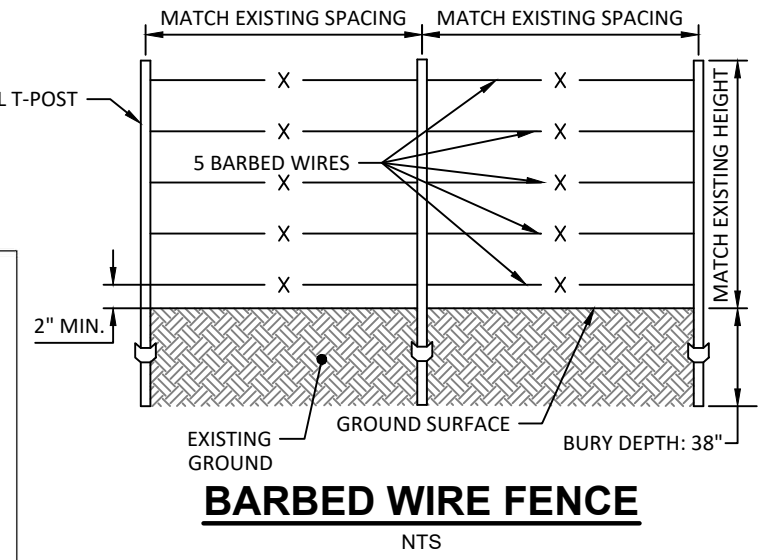

100% DESIGN

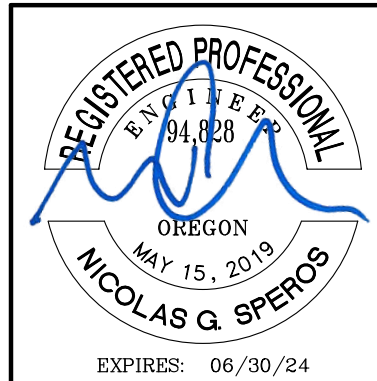

P:\03-Bend\DCO (Deschutes County)\DCO-02 (DMR Roundabout)\DCO02-DWG\Sheets\C.O.I.D. Crossing\DCO02-C3_C.O.I.D. Details.dwg

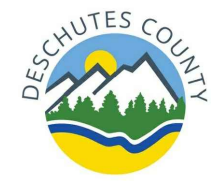

DATE	NO.	DESCRIPTION	DESIGNED:	DRAWN:	CHECKED:	DATE:
			MD	MD	NS	10.24.2022
R E V I S I O N S						

Harper Houf Peterson Righellis Inc.
ENGINEERS * PLANNERS
LANDSCAPE ARCHITECTS * SURVEYORS
250 NW Franklin Ave., Suite 404, Bend, OR 97703
phone: 541.318.1161 www.hhpr.com fax: 541.318.1141

DETAILS
C.O.I.D. CANAL CROSSING IMPROVEMENTS - DESCHUTES MARKET RD
DESCHUTES COUNTY, OREGON

SHEET NO. C3.1
JOB NO. DCO-02

TAPER TYPES & FORMULAS	
TAPER	FORMULA
Merging (Lane Closure)	"L"
Shifting	"L"/2 or 1/2"L"
Shoulder Closure	"L"/3 or 1/3"L"
Flagging (See Drg. TM850)	50' - 100'
Downstream (Termination)	Varies (See Drawings)

★ Use Pre-Construction Posted Speed to select the Speed from the Tables below:

TEMPORARY BARRIER FLARE RATE TABLE	
★ SPEED (mph)	MINIMUM FLARE RATE
≤ 30	8:1
35	9:1
40	10:1
45	12:1
50	14:1
55	16:1
60	18:1
65	19:1
70	20:1

MINIMUM LENGTHS TABLE					
"L" VALUE FOR TAPERS (ft)					BUFFER "B" (ft)
★ SPEED (mph)	W = Lane or Shoulder Width being closed or shifted				
	W ≤ 10	W = 12	W = 14	W = 16	
25	105	125	145	165	75
30	150	180	210	240	100
35	205	245	285	325	125
40	265	320	375	430	150
45	450	540	630	720	180
50	500	600	700	800	210
55	550	660	770	880	250
60	600	720	840	960	285
65	650	780	910	1000	325
70	700	840	980	1000	365
FREEWAYS					
55	1000	1000	1000	1000	250
60	1000	1000	1000	1000	285
65	1000	1000	1000	1000	325
70	1000	1000	1000	1000	365

- NOTES:
- For Lane closures where W < 10', use "L" value for W = 10'.
 - For Shoulder closures where W < 10', use "L" value for W = 10' or calculate "L" using formula, for Speeds ≥ 45: L = WS, Speeds < 45: L = S²W/60, S = Speed, W=Width

TRAFFIC CONTROL DEVICES (TCD) SPACING TABLE				
★ SPEED (mph)	Sign Spacing (ft)			Max. Channelizing Device Spacing (ft)
	A	B	C	
20 - 30	100	100	100	20
35 - 40	350	350	350	20
45 - 55	500	500	500	40
60 - 70	700	700	700	40
Freeway	1000	1500	2640	40

- NOTES:
- Place traffic control devices on 10 ft. spacing for intersection and access radii.
 - When necessary, sign spacing may be adjusted to fit site conditions. Limit spacing adjustments to 30% of the "A" dimension for all speeds.

- NOTES:
- When paved shoulders adjacent to excavations are less than four feet wide protect longitudinal abrupt edge as shown.
 - Use aggregate wedge when abrupt edge is 2 inches or greater.

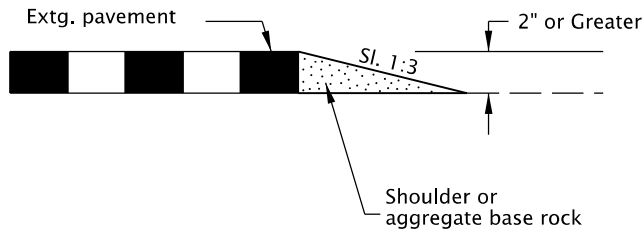

EXCAVATION ABRUPT EDGE

- NOTES:
- Abrupt edges may be created by paving, operations, excavations or other roadway work. Use abrupt edge signing for longitudinal abrupt edges of 1 inch or greater.
 - If the excavation is located on left side of traffic, replace the 8' B(III)R barricades with 8' B(III)L barricades and replace the "RIGHT" (CW21-8C) riders with "LEFT" (CW21-8A) riders.
 - Continue signing and other traffic control devices throughout excavation area at spacings shown.
 - If roll-up signs are used, attach the correct (CW21-9) plaques to the sign face using hook and loop fasteners. Place roll-up signs in advance of barricades.

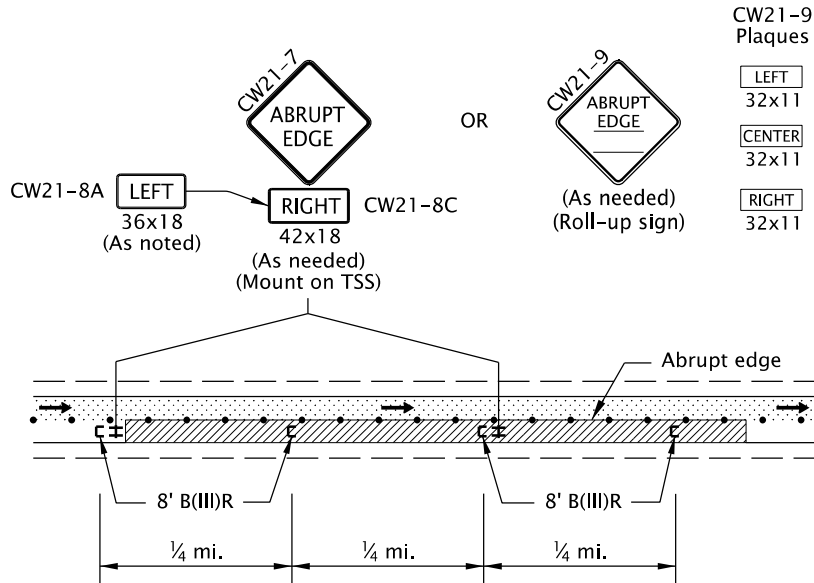

TYPICAL ABRUPT EDGE DELINEATION

- NOTES:
- Install PCMS beyond the outside shoulder, when possible.
 - Use the appropriate type of barricade panels for PCMS location. Right shoulder, use Type B(III)R. Left shoulder, use Type B(III)L.
 - Use six drums in shoulder taper on 20' spacing. The drums and barricade may be omitted when PCMS is placed behind a roadside barrier.
 - Detail as shown is used for trailered and non-crashworthy components of:
 - Portable Traffic Signals
 - Smart Work Zone Systems

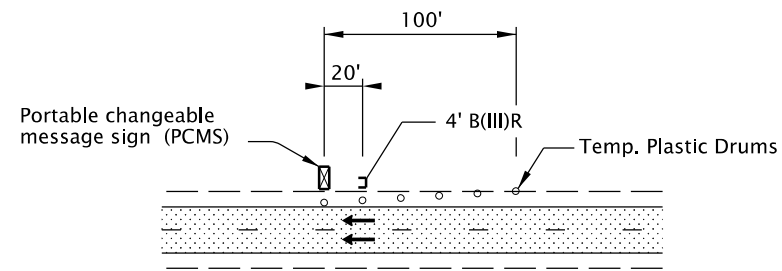

PORTABLE CHANGEABLE MESSAGE SIGN (PCMS) INSTALLATION

- NOTES:
- Install Flagger Station Lighting beyond the outside shoulder, where practical.
 - Use six tubular markers in shoulder taper on 10' spacing.
 - Place cart / generator / power supply off of the shoulder, as far as practical.

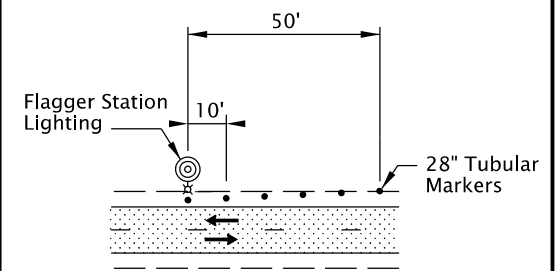

FLAGGER STATION LIGHTING DELINEATION

- GENERAL NOTES FOR ALL TCP DRAWINGS:
- Signs and other Traffic Control Devices (TCD) shown are the minimum required.
 - Place a barricade approx. 20' ahead of all sequential arrow boards.
 - Arrows shown in roadway are directional arrows to indicate traffic movements.
 - All signs are 48" x 48" unless otherwise shown. Use fluorescent orange sheeting for the background of all temporary warning signs.
 - All diamond shaped warning signs mounted on barrier sign supports shall be 36" by 36". All other signs mounted on barrier sign supports shall not exceed 12 sq. ft. in total sign area.
 - Low speed highways have a pre-construction posted speed of 40 mph or less. High speed highways have a pre-construction posted speed of 45 mph or higher.
 - Do not locate sign supports in locations designated for bicycle or pedestrian traffic.
 - Combine drawing details to complete temporary traffic control for each work activity.
 - To be accompanied by Dwg. Nos. TM820 & TM821.

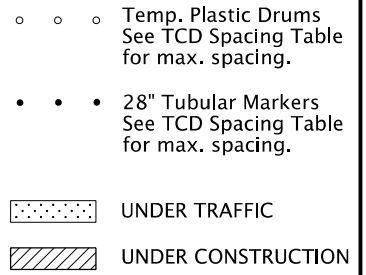

CALC. BOOK NO. ____ TM09-01 ____ SDR DATE ____ 04-JAN-2022 ____

NOTE: All material and workmanship shall be in accordance with the current Oregon Standard Specifications

OREGON STANDARD DRAWINGS

TABLES, ABRUPT EDGE AND PCMS DETAILS

2021

DATE	REVISION	DESCRIPTION

The selection and use of this Standard Drawing, while designed in accordance with generally accepted engineering principles and practices, is the sole responsibility of the user and should not be used without consulting a Registered Professional Engineer.

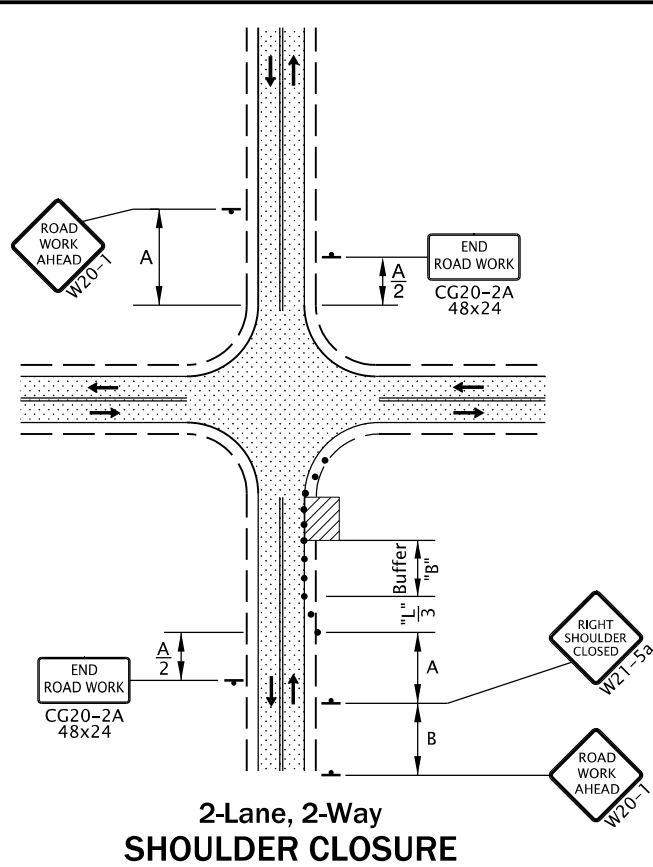

2-Lane, 2-Way SHOULDER CLOSURE

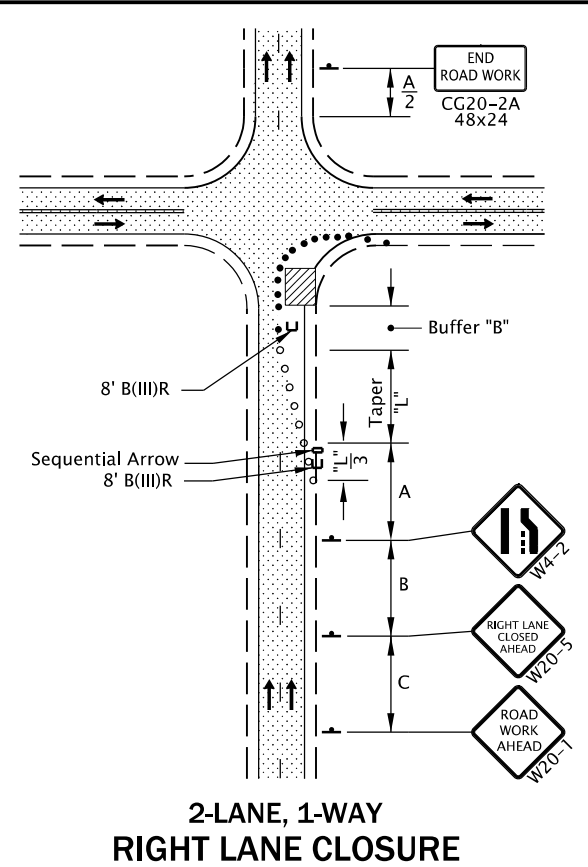

2-LANE, 1-WAY RIGHT LANE CLOSURE

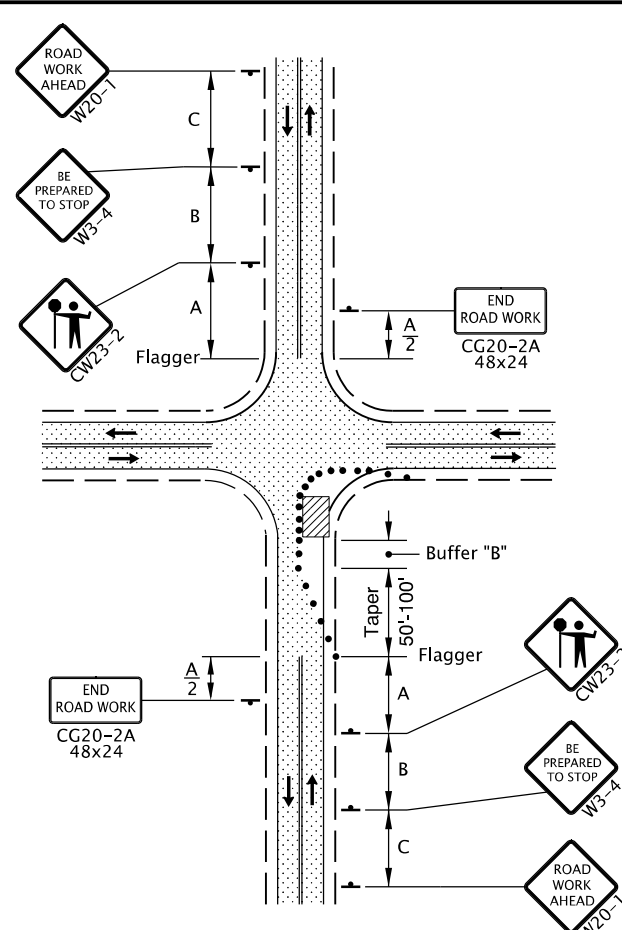

2-Lane, 2-Way ONE LANE CLOSURE

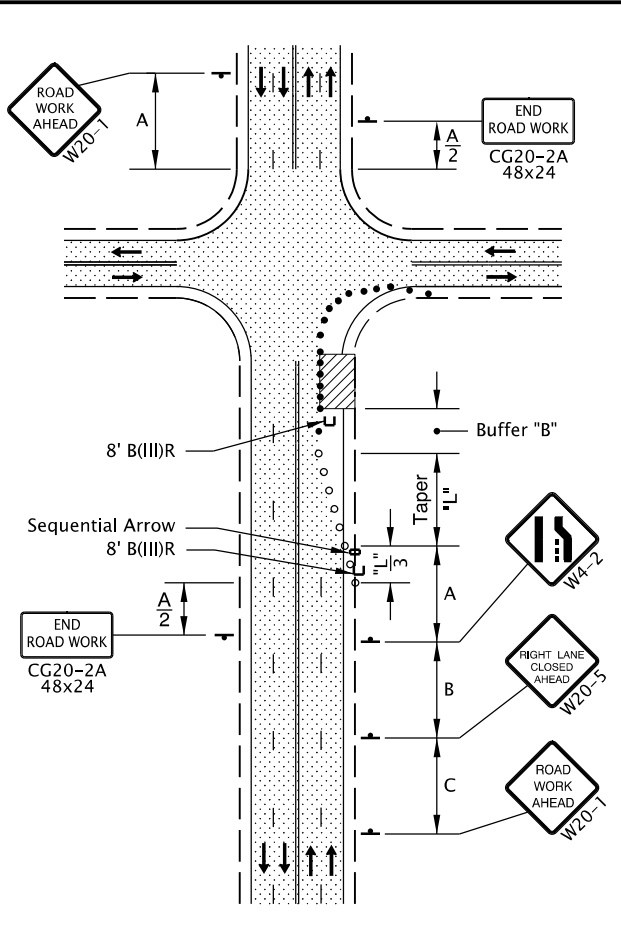

4-Lane, 2-Way RIGHT LANE CLOSURE, NEAR SIDE

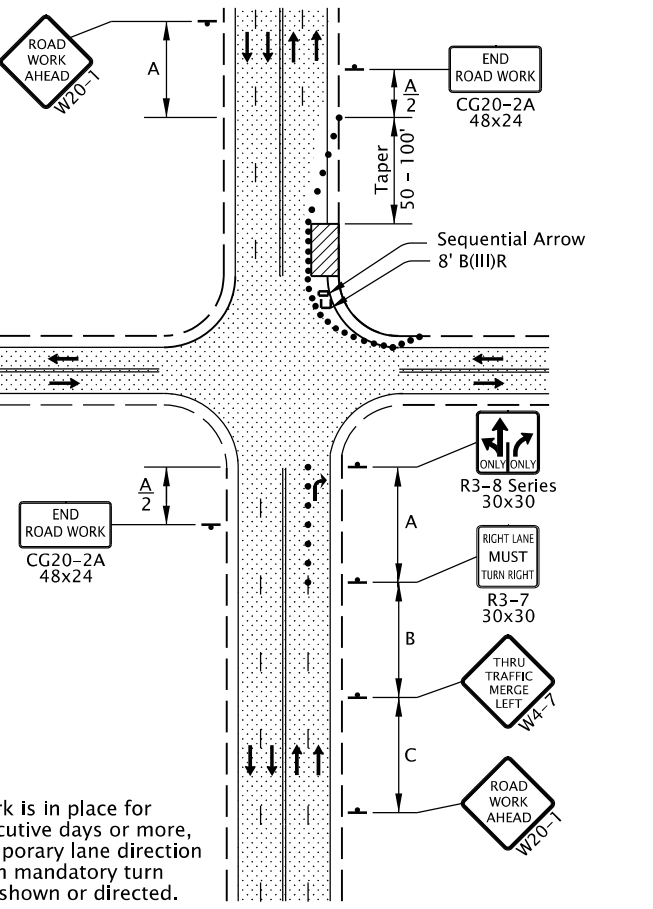

4-Lane, 2-Way RIGHT LANE CLOSURE, FAR SIDE

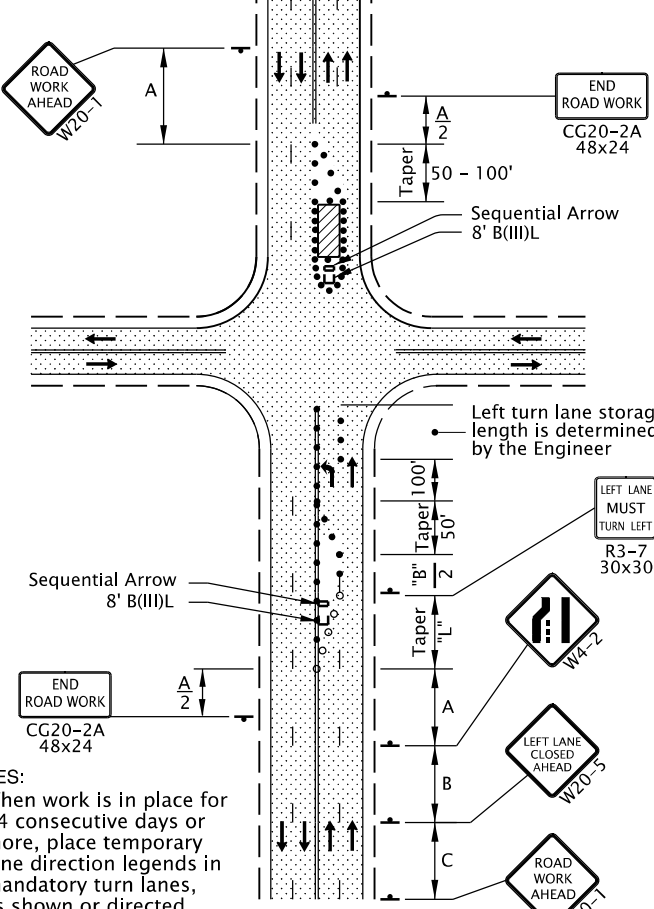

4-Lane, 2-Way LEFT LANE CLOSURE, FAR SIDE

NOTES:
 • When work is in place for 14 consecutive days or more, place temporary lane direction legends in mandatory turn lanes, as shown or directed.

NOTES:
 • When work is in place for 14 consecutive days or more, place temporary lane direction legends in mandatory turn lanes, as shown or directed.

GENERAL NOTES FOR ALL DETAILS:

- Additional Traffic Control Measures (TCM) may be required for all legs of the intersection.
- The "FLAGGER" (CW23-2) symbol sign shall be used only in conjunction with the "BE PREPARED TO STOP" (W3-4) sign.
- To determine Taper Length ("L") and Buffer Length ("B"), use the "MINIMUM LENGTHS TABLE" on Dwg. TM800.
- For left lane or shoulder work, place TCD to close left lane or shoulder. Use "LEFT LANE CLOSED AHEAD" (W20-5) sign, "LEFT LANE ENDS" (W4-2L) symbol sign, or "LEFT SHOULDER CLOSED" (W21-5a) sign, where applicable.
- To determine sign spacing A, B, and C, use "TRAFFIC CONTROL DEVICES (TCD) SPACING TABLE" on Dwg. TM800.
- When a through road intersects within the work zone, place a "ROAD WORK AHEAD" (W20-1) sign in advance of the intersection at sign spacing A.
- Tubular markers may be used in lane closure tapers where posted speed is 40 mph or less.
- Where shoulder width is limited, Sequential Arrow may be placed within the lane closure taper.
- Place channelling devices around intersection radii, business accesses and driveways at 10' spacing.
- Install a "BICYCLES ON ROADWAY" (CW11-1) sign in advance of the closure when a bike lane is closed, or when the shoulder is closed and bikes are expected.
- To be accompanied by Dwg. Nos. TM820, TM821 & TM840.

- • • • • 28" Tubular Markers
See TCD Spacing Table on TM800 for max. spacing.
- • • • • Temp. Plastic Drums
See TCD Spacing Table on TM800 for max. spacing.

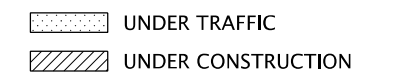

<p>CALC. BOOK NO. _____ N/A _____</p> <p><i>The selection and use of this Standard Drawing, while designed in accordance with generally accepted engineering principles and practices, is the sole responsibility of the user and should not be used without consulting a Registered Professional Engineer.</i></p>	<p>SDR DATE _____ 01-JUL-2020 _____</p> <p>NOTE: All material and workmanship shall be in accordance with the current Oregon Standard Specifications</p> <p>OREGON STANDARD DRAWINGS</p> <p>INTERSECTION WORK ZONE DETAILS</p> <p>2021</p> <table border="1"> <thead> <tr> <th>DATE</th> <th>REVISION</th> <th>DESCRIPTION</th> </tr> </thead> <tbody> <tr> <td> </td> <td> </td> <td> </td> </tr> <tr> <td> </td> <td> </td> <td> </td> </tr> <tr> <td> </td> <td> </td> <td> </td> </tr> </tbody> </table>	DATE	REVISION	DESCRIPTION									
DATE	REVISION	DESCRIPTION											

tm850.dgn 01-JUL-2020

- NOTE:
- Continue "LOOSE GRAVEL" (CW8-7a) and "DO NOT PASS" (R4-1) signing throughout the area at spacing shown.
 - Use advisory speed "XX", 15 mph less than the pre-construction posted speed, or as directed. "XX MPH" placard shall not exceed a posted speed of 35 mph.

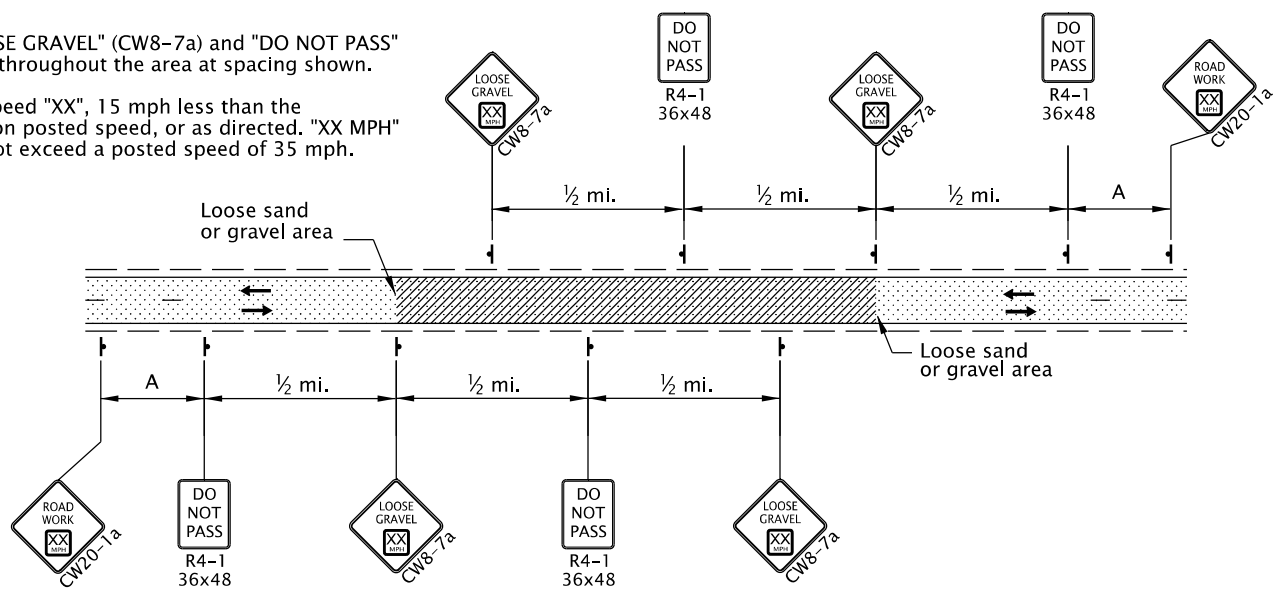

**2-Lane, 2-Way Roadway
LOOSE GRAVEL IN ROADWAY SIGNING**

- NOTE:
- Continue "ABRUPT EDGE" (CW21-(7,9)) and "DO NOT PASS" (R4-1) signing throughout the area at spacing shown.

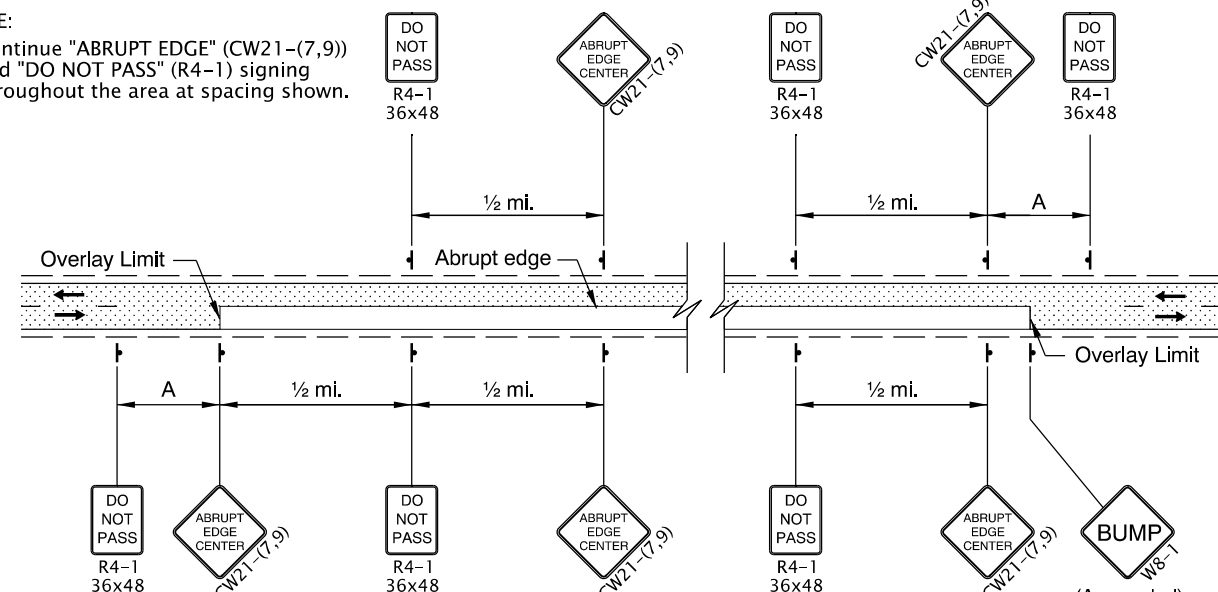

**2-Lane, 2-Way Roadway
OVERLAY AREA SIGNING**

- NOTES:
- Place Advance Flagger and additional signing when traffic queues extend beyond initial warning signing OR when sight distance is restricted.
 - Relocate initial "ROAD WORK AHEAD" (W20-1) sign in advance of additional "BE PREPARED TO STOP" (W3-4) and Flagger Ahead (CW23-2) signs, as shown.

- Place additional Tubular Markers for Flagger and Advance Flagger Stations according to FLAGGER STATION DELINEATION detail.

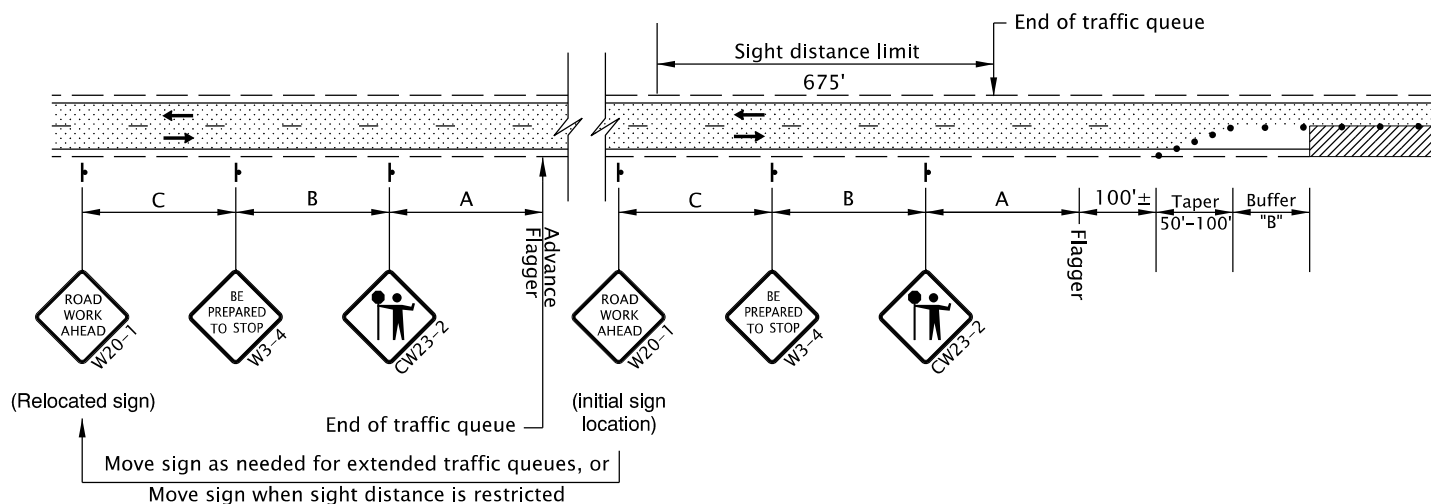

ADVANCE FLAGGER FOR EXTENDED TRAFFIC QUEUES

- NOTE:
- When using pilot cars with flaggers to control traffic during paving operations, the Tubular Marker spacing along centerline may be increased to 200' within the Activity Area, as shown or as directed.
 - Include "WAIT FOR FLAGGER" (CR4-23) signs mounted on Type II Barricade located approx. 50' before each Flagger.
 - Coordinate and control pedestrians movements through the TPAR using Flaggers, other TCM, or as directed. When the existing shoulder is greater than or equal to 4' wide, provide a minimum of 4' of width for the TPAR.

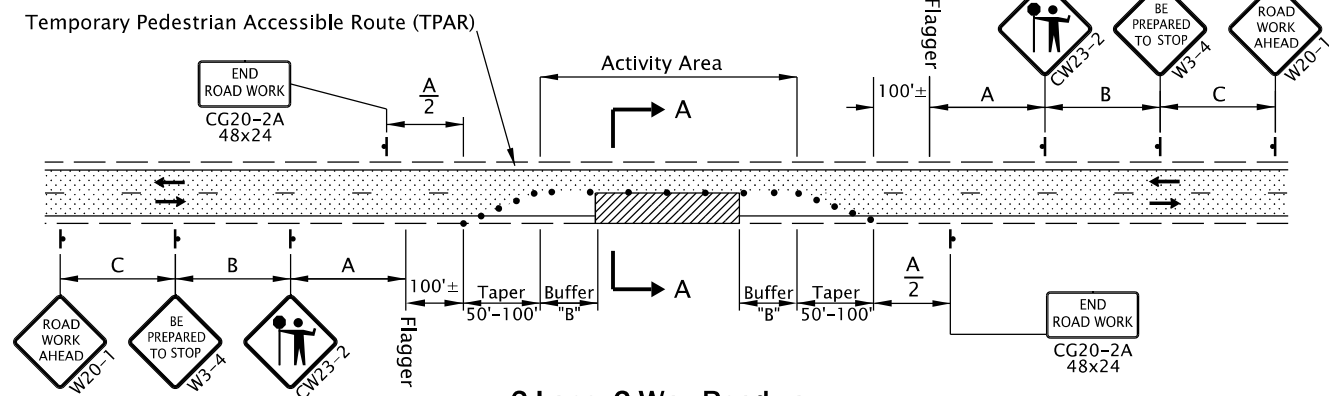
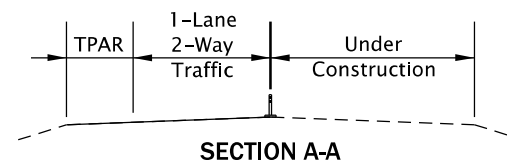

**2-Lane, 2-Way Roadway
ONE LANE CLOSURE**

GENERAL NOTES FOR ALL DETAILS:

- The "FLAGGER" (CW23-2) symbol sign shall be used only in conjunction with the "BE PREPARED TO STOP" (W3-4) sign.
- Cover existing passing zone signing, as directed.
- Install temporary striping as required.
- To determine Taper Length ("L") and Buffer Length ("B"), use the "MINIMUM LENGTHS TABLE" shown on Dwg. No. TM800.
- To determine sign spacing A, B, and C, use "TRAFFIC CONTROL DEVICES (TCD) SPACING TABLE" on Dwg. No. TM800.
- Install a "BICYCLES ON ROADWAY" (CW11-1) sign in advance of the closure when a bike lane is closed, or when the shoulder is closed and bikes are expected.
- At night, flagger stations shall be illuminated according to the FLAGGER STATION LIGHTING DELINEATION detail on Dwg No. TM800.

- To be accompanied by Dwg. Nos. TM820 & TM821.

- • • • • 28" Tubular Markers on 20' max. spacing for flagger tapers and stations
- • • • • 28" Tubular Markers See TCD Spacing Table on TM800 for max. spacing.

- UNDER TRAFFIC
- UNDER CONSTRUCTION
- CONSTRUCTION UNDER TRAFFIC

- NOTE:
- Use a minimum of 3 tubular markers in shoulder taper on 10' spacing for flagger station delineation.

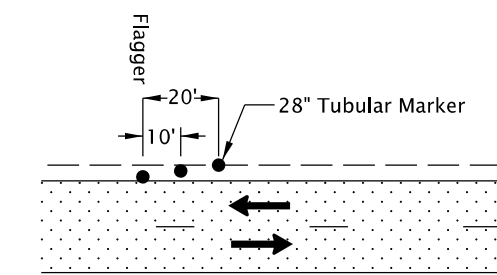

FLAGGER STATION DELINEATION

CALC. BOOK NO. _____ N/A _____ SDR DATE _____ 01-JUL-2020 _____

NOTE: All material and workmanship shall be in accordance with the current Oregon Standard Specifications

**OREGON STANDARD DRAWINGS
2-LANE, 2-WAY ROADWAYS**

2021

DATE	REVISION DESCRIPTION

TM850